

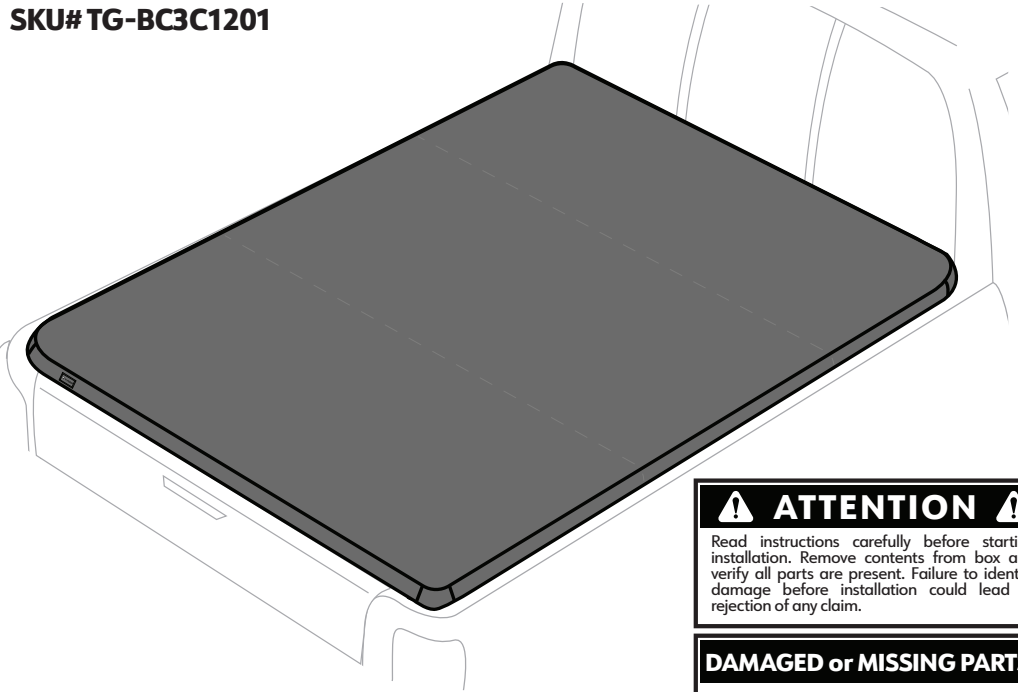

TYGER[®]

T3 | SOFT TRI-FOLD TONNEAU COVER

SKU# TG-BC3C1201



⚠ ATTENTION ⚠

Read instructions carefully before starting installation. Remove contents from box and verify all parts are present. Failure to identify damage before installation could lead to rejection of any claim.

DAMAGED or MISSING PARTS?

NEED HELP?

contact us: **1-866-340-3038**

PARTS LIST (ONLY MARKED ITEMS ARE INCLUDED)

Bed Cover

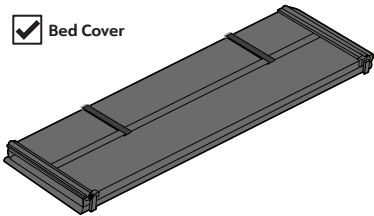

SP-BC3002



SP-BC0006



SP-BC3003B



SP-BC3060

SP-BC3004



SP-BC3005



SP-BC0003
Front Seal Strip
170 x 2.5 x 1 cm

SP-BC0004
Front Seal Strip
170 x 3.5 x 0.4 cm

SP-BC0005
Spare Seal Strip
200 x 3.0 x 0.6 cm



SEAL STRIP

Only needed
for certain models



1 APPLYING SEAL STRIP

IF THE TRUCK'S FRONT BED RAIL IS LOWER THAN THE SIDES, USE THE PROVIDED WEATHER SEAL STRIPS. GAPS ON THE FRONT BED AND TAILGATE CAN CAUSE NOISE AND FLAPPING ISSUES WHILE DRIVING ALONG WITH WATER LEAKAGE.

NOTE: SPARE SEALING STRIP (SP-BC0005) IS INCLUDED IN CASE ADDITIONAL SEALING IS NEEDED AROUND THE BED AREA.

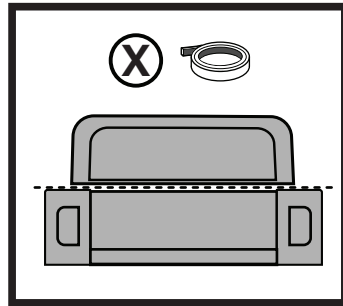
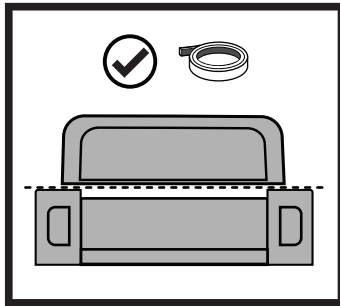
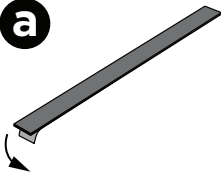
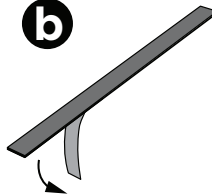
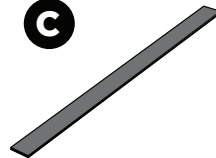
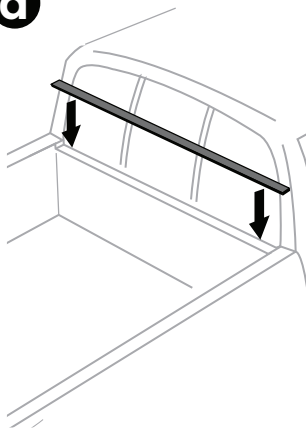
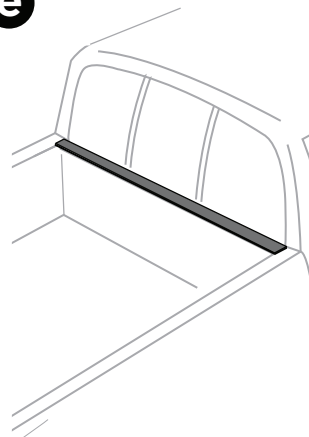
a

b

c

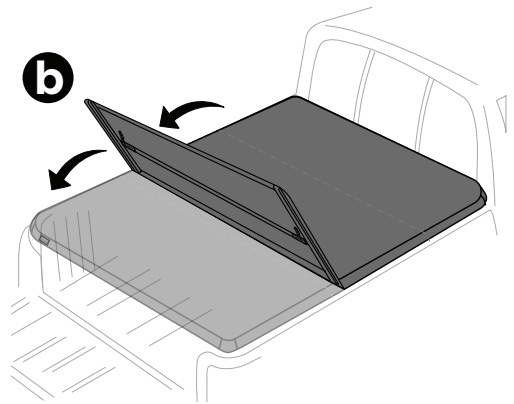
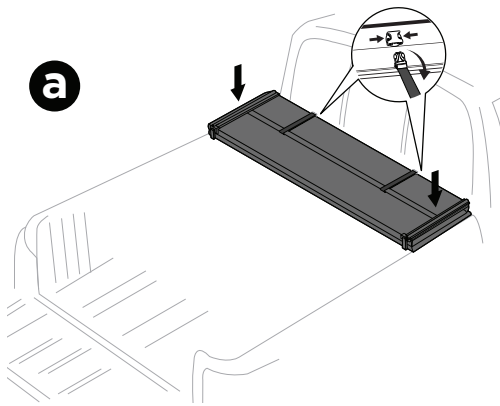
d

e

2 LAYING OUT THE COVER

- PLACE THE FOLDED COVER ASSEMBLY ON THE BED RAIL AND ALIGN THE FRONT EDGE ALL THE WAY WITH THE OUTER EDGE OF THE BED RAIL.
- RELEASE THE SAFETY BUCKLES AND FULLY UNFOLD THE COVER TOWARDS THE TAILGATE. BOTH SIDES SHOULD ALIGN EVENLY WITH THE SIDE BED RAILS.



C

- C-1** • Align the front of the cover against the outer edge at the midpoint of the front bed rail.
- C-2** • ALIGN BOTH SIDES OF THE COVER EVENLY ON THE SIDE BED RAILS. THE WIDTH OF THE COVER DOES NOT COVER ALL THE WAY TO THE OUTER EDGES OF THE SIDE RAILS.

NOTE: FOR 2024-UP MODEL YEARS

MOVE THE COVER ASSEMBLY ~5/8" TOWARDS THE TAILGATE FOR BETTER ALIGNMENT.

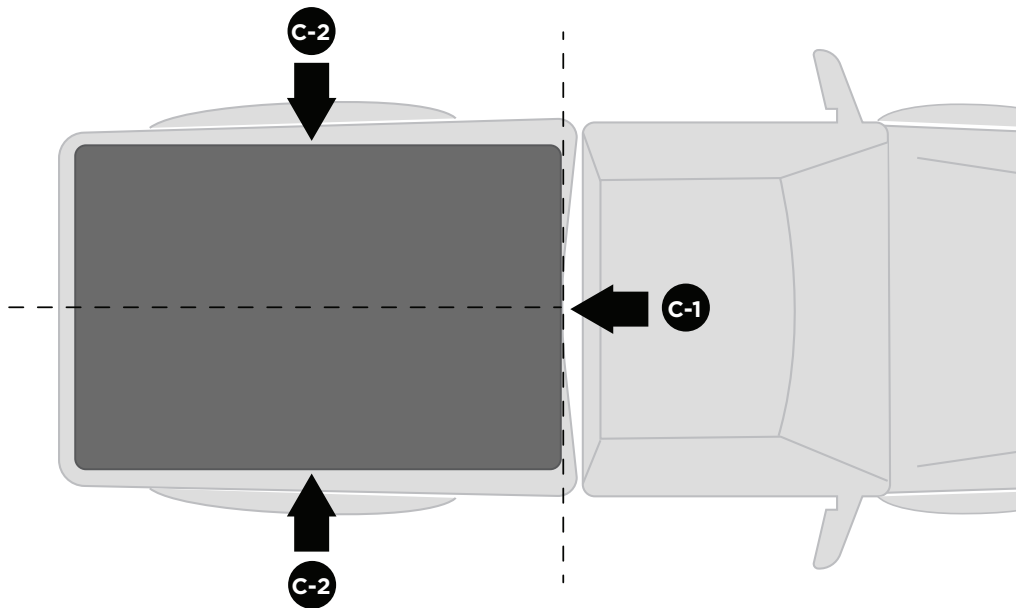

3 FOLDING BACK THE COVER

• CAREFULLY REFOLD THE COVER WITHOUT MOVING ITS POSITION ON THE TRUCK BED.

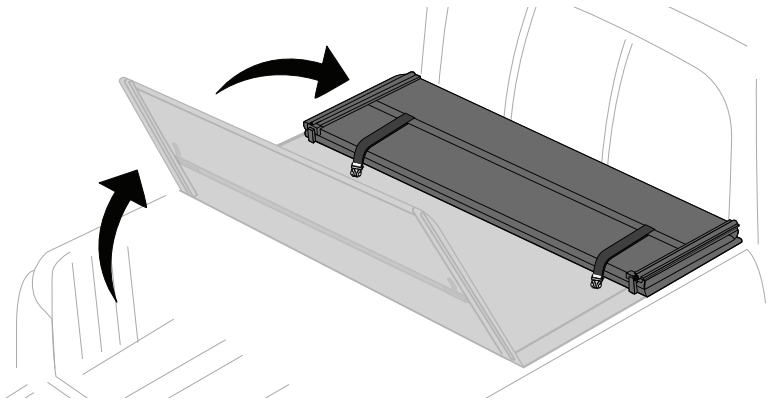

4 CLAMPS & LATCHES OVERVIEW

• THE CLAMPS AND LATCHES ARE ALREADY ATTACHED TO THE ASSEMBLED COVER.

NOTE: FOR MODELS WITH UTILITY TRACK, REFER TO **PAGE 12** FOR INSTRUCTION ON UTILITY TRACK BRACKET INSTALLATION.

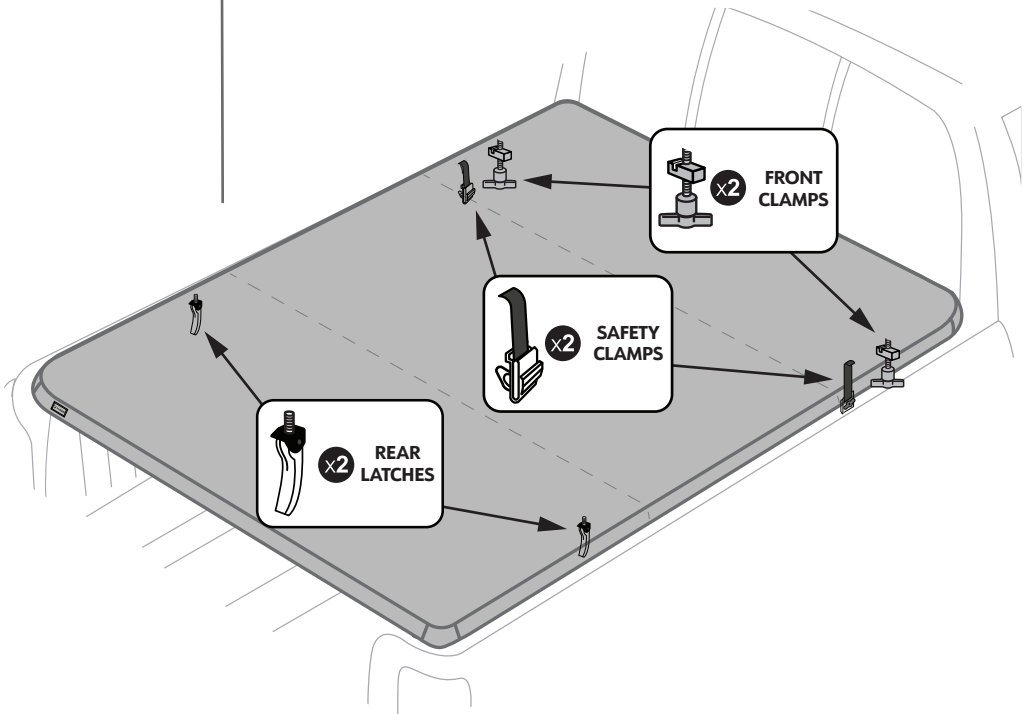

5 APPLYING FRONT CLAMPS ⓘ

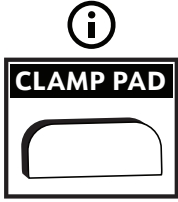
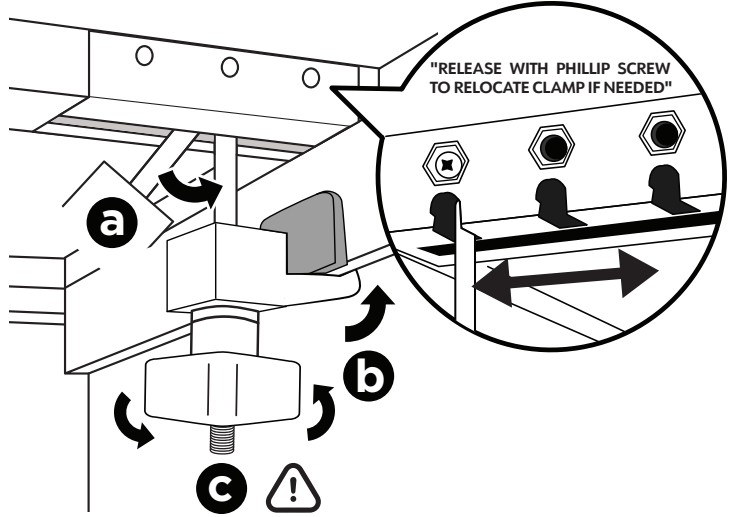

- a** • PULL DOWN FRONT CLAMPS INTO VERTICAL POSITION.
- b** • HOOK THE JAW OF THE CLAMP ONTO THE METAL BED RAIL LIP. CLAMP PAD CAN BE INSERTED TO PROTECT THE PAINT.
- c** • TURN THE KNOB UNTIL SIDE Q-SEAL ON THE COVER IS COMPRESSED AND THE CLAMP IS SNUG.

ⓘ TYPE A

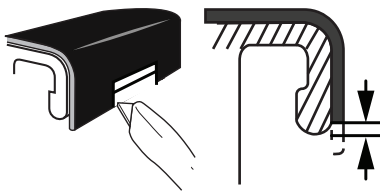

ⓘ TYPE B

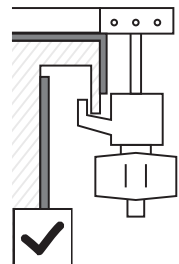
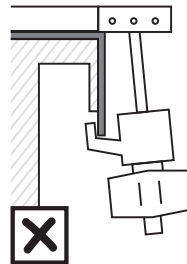
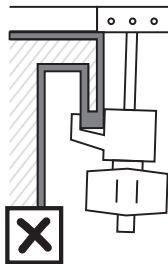
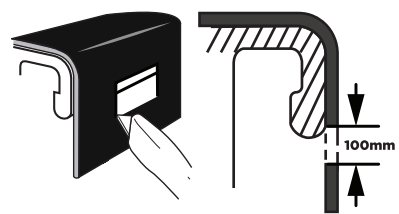

NOTE

Safety clamps must be secured properly to the metal part of the bed rail while the vehicle is in motion, otherwise the warranty will be voided.

ATTENTION

DO NOT use wrench or overtighten!

6 APPLYING SAFETY CLAMPS

- TURN THE KNOB COUNTERCLOCKWISE TO LOOSEN THE SAFETY CLAMP WITH THE STRAP, ATTACH CLAMP TO THE METAL BED RAIL LIP ON BOTH SIDES, THEN TIGHTEN.

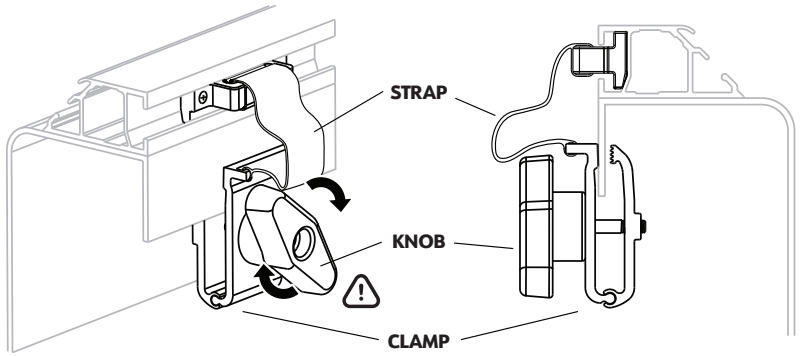

7 UNFOLD THE TONNEAU COVER

- UNFOLD THE COVER COMPLETELY TOWARDS THE TAILGATE.

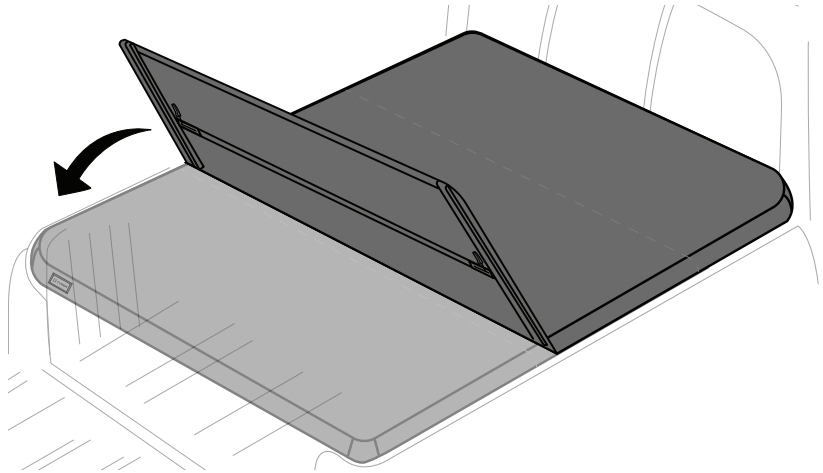

8 FASTENING REAR LATCHES ⓘ



NOTE

All latches & clamps must make solid contact with the metal bed rail lip for the cover to be secured.

YOU NEED

Phillips-Head
Screwdriver

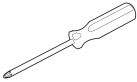

"RELEASE WITH PHILLIP SCREW
TO RELOCATE LATCH IF NEEDED"

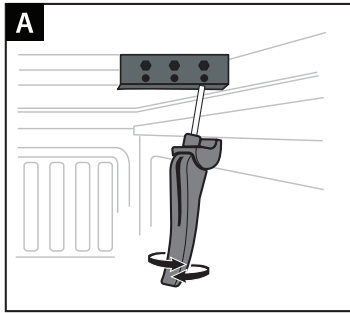
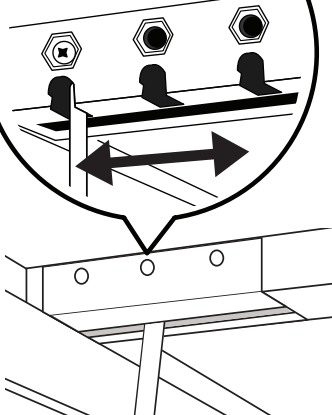

A: START BY PULLING DOWN LATCH HANDLE FROM THE BACK OF COVER. THEN UNSCREW THE HANDLE TO LOWER ITS POSITION.

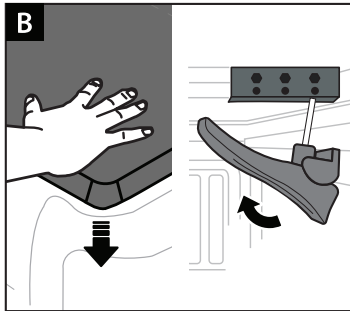

B: WITH ONE HAND, LIFT AND KEEP THE LATCH HANDLE POINTING UP AS MUCH AS POSSIBLE (BEYOND 90°). THEN, WITH THE OTHER HAND FIRMLY PRESSED DOWN ONTO THE COVER CORNER. CONTINUE TO ROTATE HANDLE TO ADJUST THE POSITION.

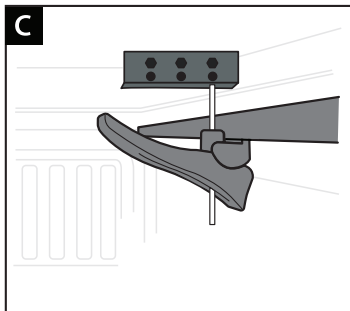

C: FOR THE TIGHTEST FIT, OPENING OF LATCH JAW SHOULD BE LEVEL WITH THE SIDE RAIL LIP WITHOUT LIMITING ACCESS TO THE JAW.

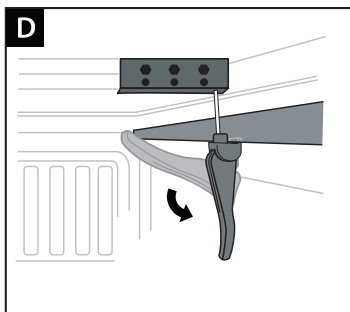

D: LATCH THE JAW GROOVE FULLY INTO THE RAIL LIP, THEN CRANK HANDLE DOWN TO TIGHTEN. GO BACK AND READJUST JAW POSITION FROM STEP B IF THE LATCH DOES NOT FEEL VERY TIGHT.



NOTE

Cover may not completely cover to the outside edge of the bed rails due to slight difference in truck bed shape for different year models

9 FINISHING INSTALLATION

- AFTER REAR LATCHES ARE SECURELY FASTENED, SHUT & LOCK THE TAILGATE SO THE COVER CANNOT BE OPENED FROM THE OUTSIDE.

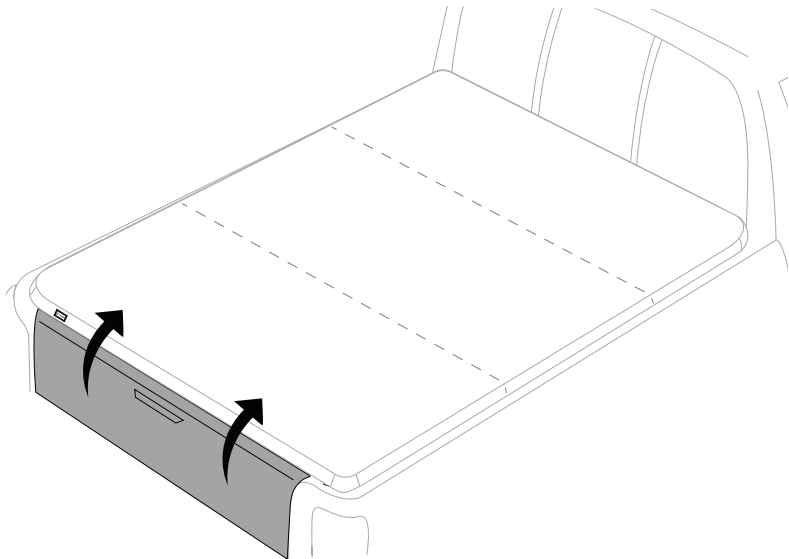

10 CHECKING FOR GAPS

- WITH THE TAILGATE OPEN, VISUALLY INSPECT FOR LIGHT LEAKING THROUGH THE GAPS. APPLY ADDITIONAL SEALING STRIPS TO FILL THE GAPS THEN REINSPECT AND REPEAT.



SEAL STRIP

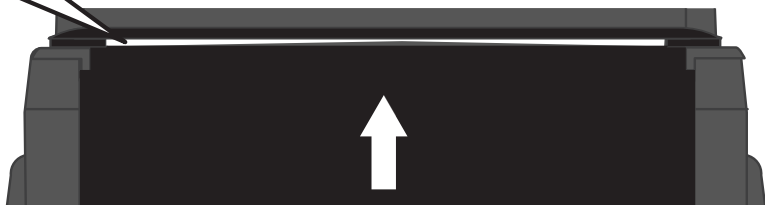
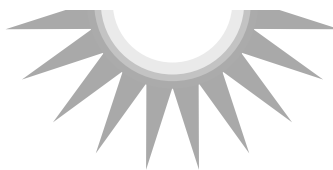

INSTALLATION COMPLETE!!!

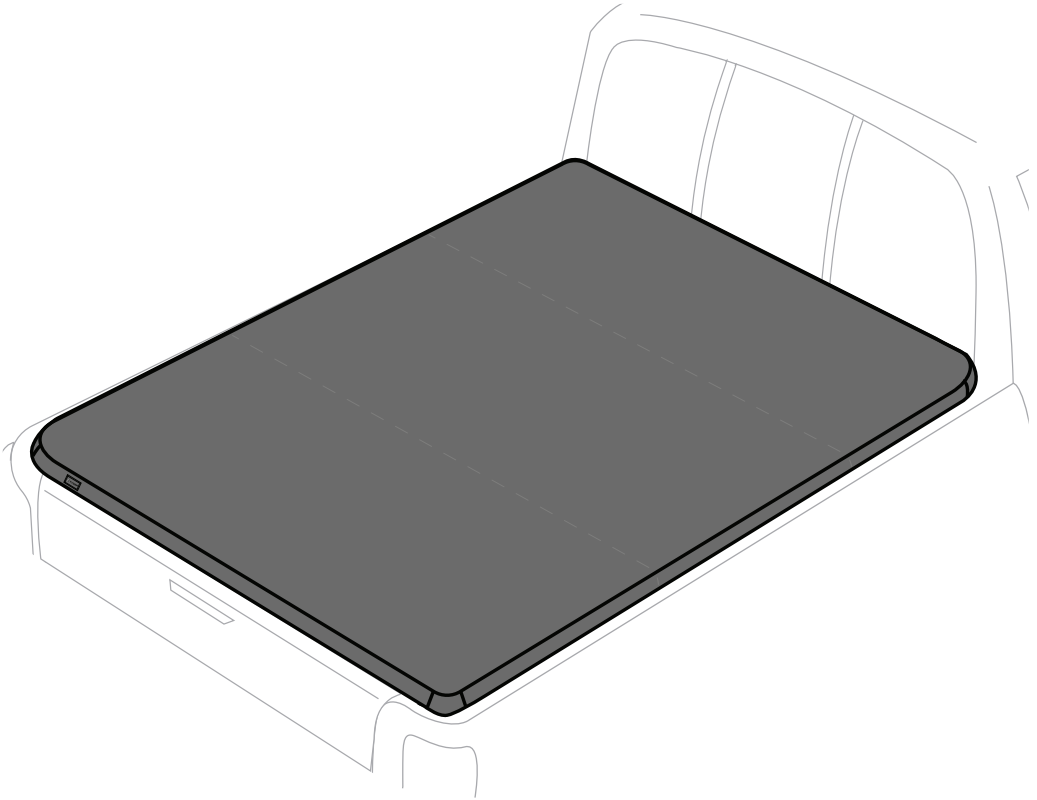

DO NOT
overload cargo



DO NOT place
sharp objects on top



Remove snow before
folding up cover



Secure strap buckles
before driving



Use seal strips for
Exposed gaps to
Avoid leaking



Use water and
soap to clean.
Avoid abrasive
chemical cleaners

AFTER INSTALLATION

11 FOLDING UP THE COVER

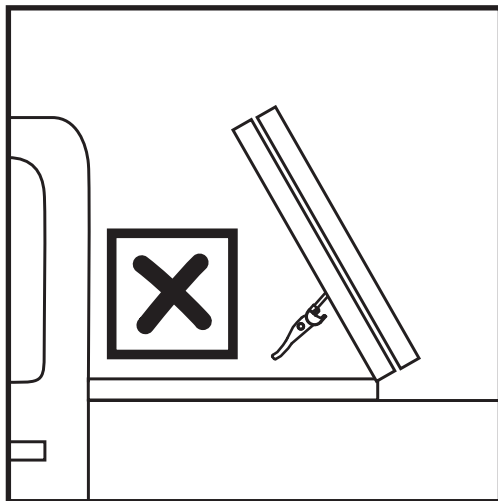

- REAR LATCHES MUST BE TUCKED IN BEFORE YOU FOLD BACK THE COVER.

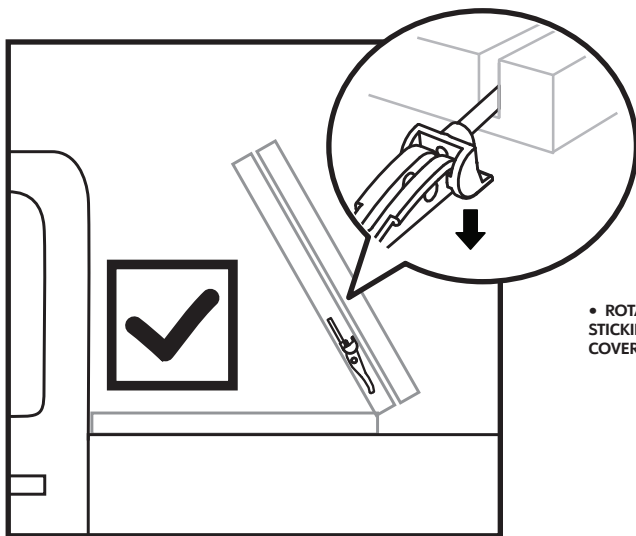

- ROTATE THE LATCH SO THE JAW IS NOT STICKING OUT FROM THE UNDER-SIDE OF THE COVER.



NOTE

DO NOT release the front clamps and safety clamps when you unfold the cover, and make sure they are all secured!

a

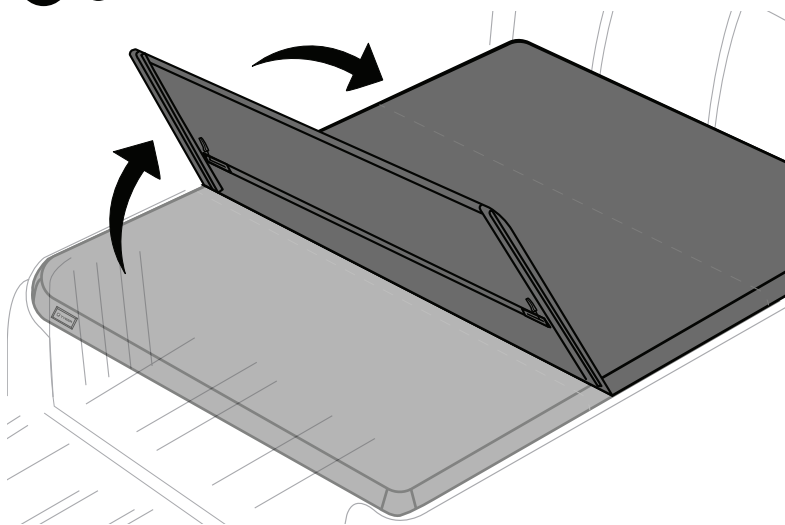

CLICK!!!

b

• ENSURE THE SAFETY BUCKLES ARE PROPERLY SECURED ON BOTH SIDES.

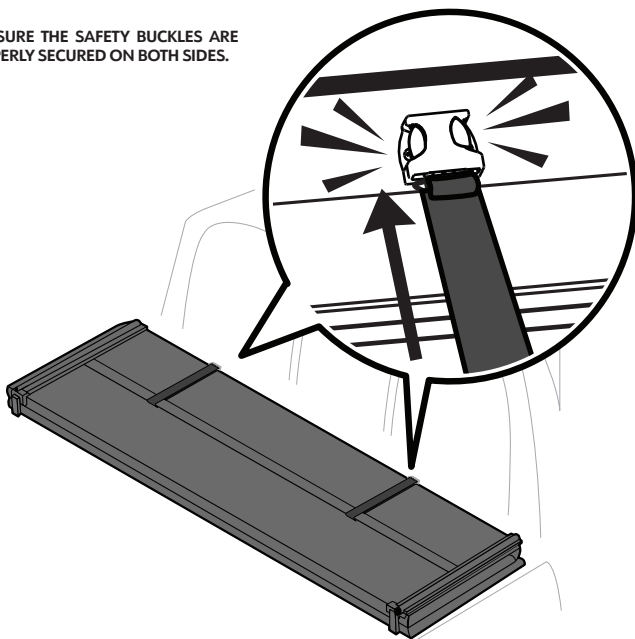

12 FOR MODELS WITH UTILITY TRACKS

For NISSAN FRONTIER

You will need:



SP-BC3005

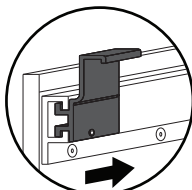
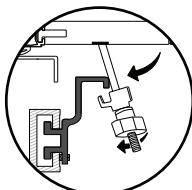
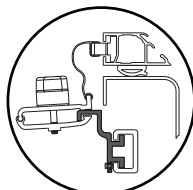
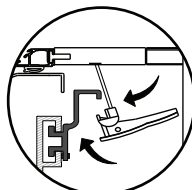

a Slide aluminum blocks into track

b Attach **Front Clamps** on to aluminum block

c Attach **Safety Clamps** on to aluminum block

d Attach **Rear Latches** on to aluminum block

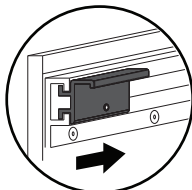
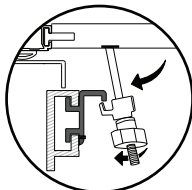
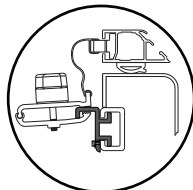
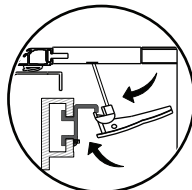
For NISSAN TITAN

You will need:



SP-BC3004



a Slide aluminum blocks into track

b Attach **Front Clamps** on to aluminum block

c Attach **Safety Clamps** on to aluminum block

d Attach **Rear Latches** on to aluminum block

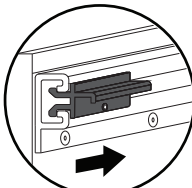
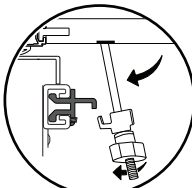
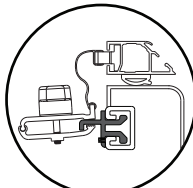
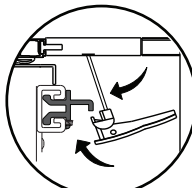
For TOYOTA TACOMA & TUNDRA

You will need:



SP-BC3003B



a Slide aluminum blocks into track

b Attach **Front Clamps** on to aluminum block

c Attach **Safety Clamps** on to aluminum block

d Attach **Rear Latches** on to aluminum block

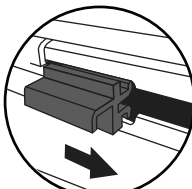
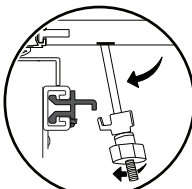
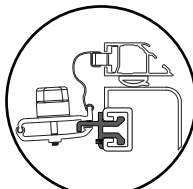
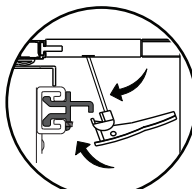
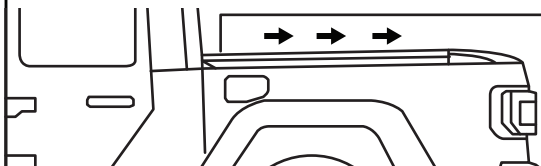
For JEEP GLADIATOR

You will need:



SP-BC3060

a Slide aluminum blocks into track

b Attach **Front Clamps** on to aluminum block

c Attach **Safety Clamps** on to aluminum block

d Attach **Rear Latches** on to aluminum block

**JEEP GLADIATOR:
SLIDE BRACKET FROM THE FRONT**