



STAR ARMOR®

TG-AM2N20158

BEFORE INSTALLATION

READ INSTRUCTIONS CAREFULLY BEFORE STARTING INSTALLATION. REMOVE CONTENTS FROM BOX AND VERIFY ALL PARTS ARE PRESENT. FAILURE TO IDENTIFY DAMAGE BEFORE INSTALLATION COULD LEAD TO A REJECTION OF ANY CLAIM. IF MISSING PARTS OR ANY DAMAGE FOUND, PLEASE TAKE A PICTURE FOR THE CLAIM PURPOSE. TO FILE YOUR CLAIM, PLEASE VISIT: WWW.TYGERAUTO.COM/CONTACT

TORQUE VALUES

Fastener Size	Class 8.8 Torque (ft-lbs)	Class 10.9 Torque (ft-lbs)
6mm	6-7	6-7
8mm	15-16	22-23
10mm	31-32	44-45
12mm	54-55	78-79
14mm	87-88	125-126

x1 Driver/Left Side Tyger Star Armor

x1 Passenger/Right Side Tyger Star Armor

x12 8mm Flange Nuts

x12 8mm x 24mm OD x 1.6mm Flat Washers

Parts List

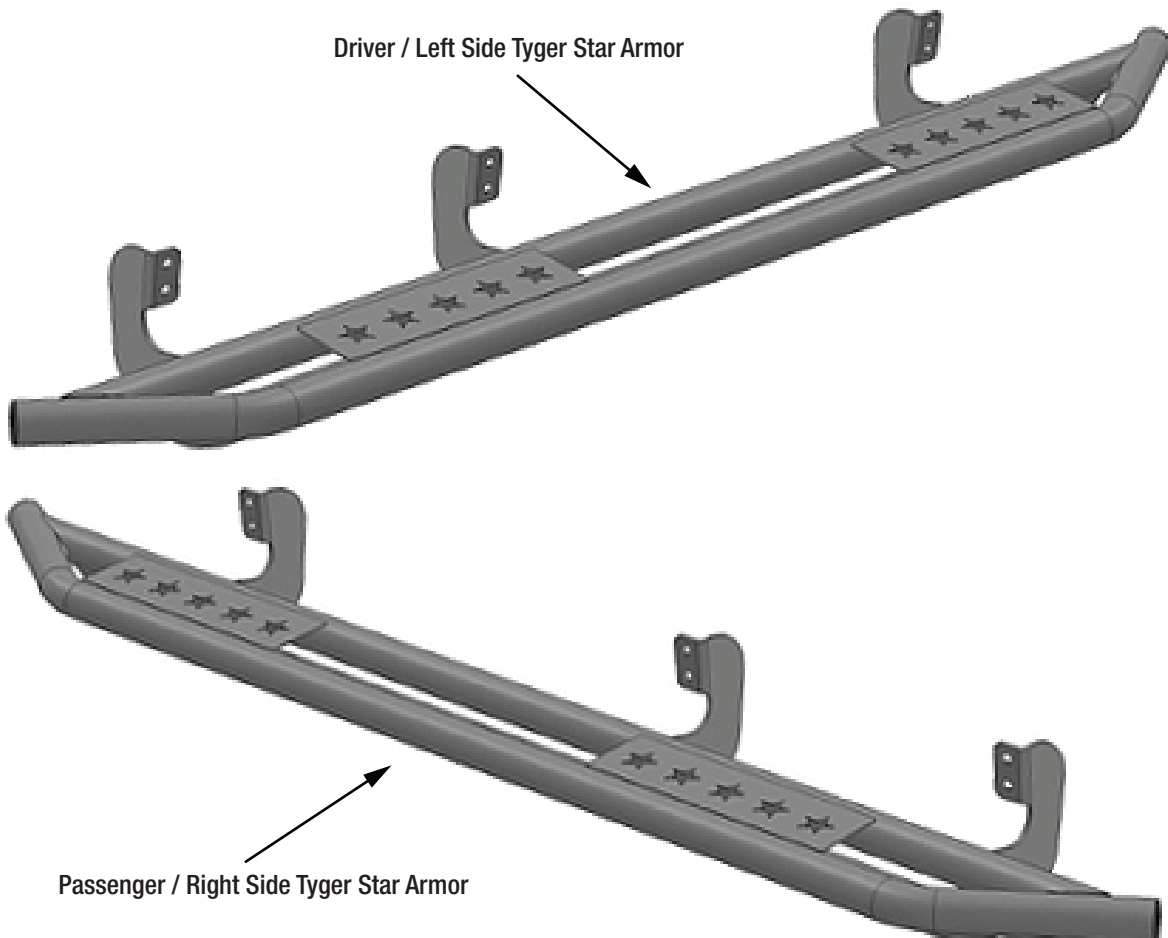

PROCEDURE:

REMOVE CONTENTS FROM BOX. VERIFY ALL PARTS ARE PRESENT. READ INSTRUCTIONS CAREFULLY. ASSISTANCE IS HIGHLY RECOMMENDED.

STEP 1

Starting on the driver/left side of the vehicle, locate the factory running board mounting studs along the inner body panel (Figs 1-3). Remove any paint or undercoating from the studs before starting installation. **NOTE:** If necessary, hold the driver/left Side Armor up in position to help locate correct mounting locations.

Driver/Left Side Installation Pictured

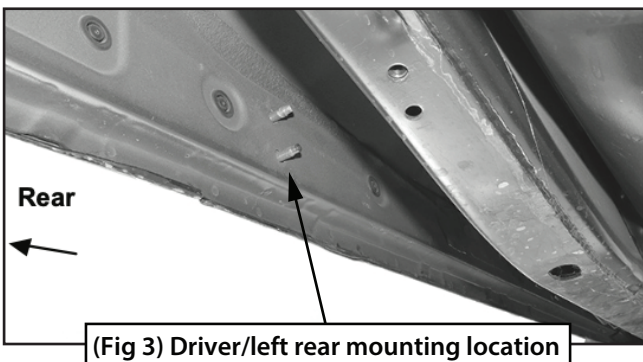
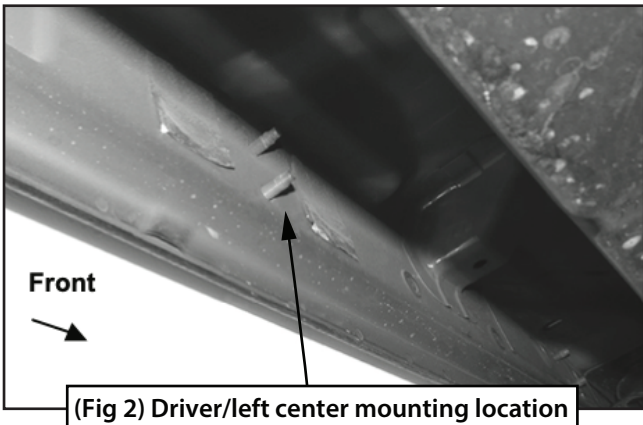
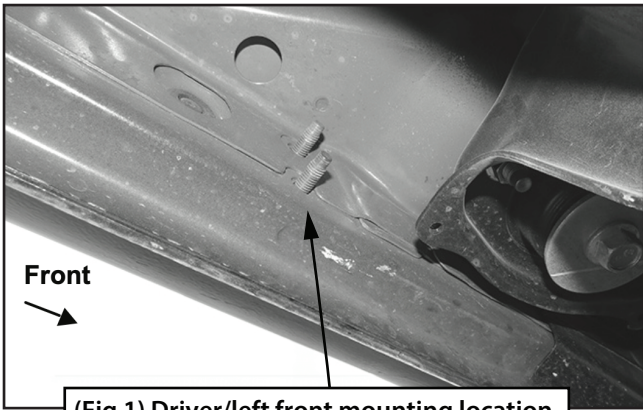

STEP 2

With assistance, line up the (3) mounting brackets on the Side Armor with the factory threaded studs in the inner body panel. Attach the Side Armor to the studs with the included (6) 8mm Flat Washers and (6) 8mm Flange Nuts (Figs 4-6). Leave hardware loose.

Driver/Left Side Installation Pictured

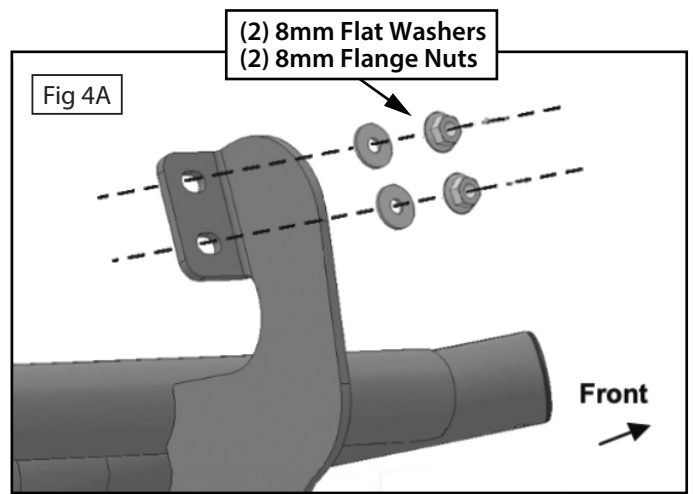

ATTENTION: Some Frontier models have front factory studs that are too short to fit both Flat Washers and Flange Nuts. In this case, **omit the Flat Washers and only install the Flange Nuts.** (Fig 4B)

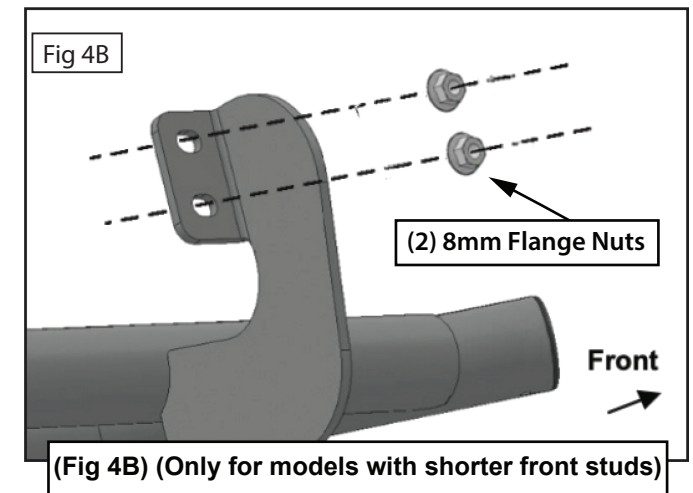

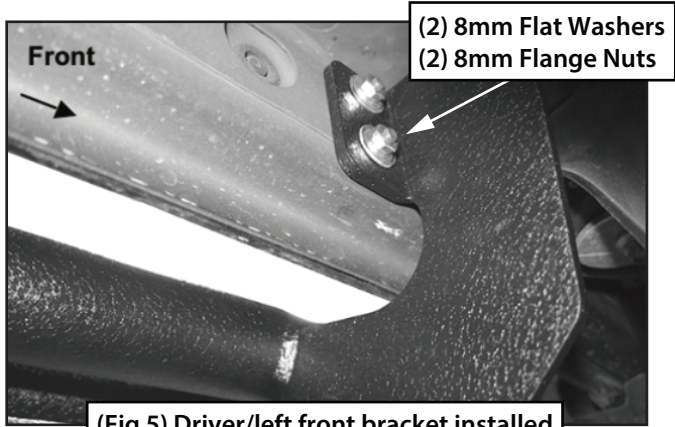

(Fig 5) Driver/left front bracket installed

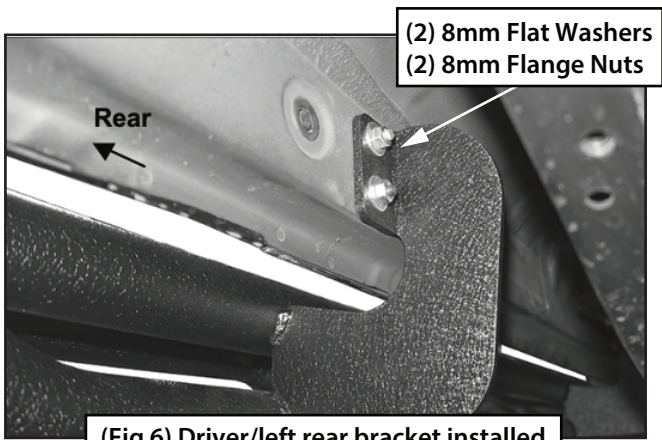

(Fig 6) Driver/left rear bracket installed

STEP 3

Adjust the position as necessary and fully tighten all hardware.

Driver/Left Side Installation Pictured



Complete Installation

STEP 4

Repeat **STEPS 1-3** for Passenger/Right side Tyger Armor installation.

STEP 5

Do periodic inspections to the installation to make sure that all hardware is secure and tight.