



TYGER ACCESS

TG-AS2C24001

Scan to Download the Latest Digital Version



BEFORE INSTALLATION

READ INSTRUCTIONS CAREFULLY BEFORE STARTING INSTALLATION. REMOVE CONTENTS FROM BOX AND VERIFY ALL PARTS ARE PRESENT. FAILURE TO IDENTIFY DAMAGE BEFORE INSTALLATION COULD LEAD TO A REJECTION OF ANY CLAIM. IF MISSING PARTS OR ANY DAMAGE FOUND, PLEASE TAKE A PICTURE FOR THE CLAIM PURPOSE. TO FILE YOUR CLAIM, PLEASE VISIT: WWW.TYGERAUTO.COM/CONTACT

TORQUE VALUES

Fastener Size	Class 8.8 Torque (ft-lbs)	Class 10.9 Torque (ft-lbs)
6mm	6-7	6-7
8mm	15-16	22-23
10mm	31-32	44-45
12mm	54-55	78-79
14mm	87-88	125-126

- x1** Driver/Left Tyger Access
- x1** Passenger/Right Tyger Access
- x4** Driver/Left Mounting Brackets [A]
- x4** Passenger/Right Mounting Brackets [B]
- x16** 8mm Lock Washers
- x16** 8mm x 24mm OD x 2mm Flat Washers
- x16** 8-1.25mm x 30mm Hex Bolts
- x16** 8-1.25mm x 25mm Hex Combo Bolts

Parts List

Top View

ATTENTION: Refer to **D** and **P** labelling on the side of the tubes to determine Driver and Passenger TYGER Access

P Passenger Side TYGER Access

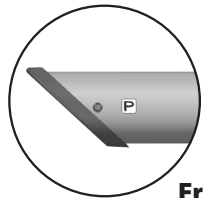

Front

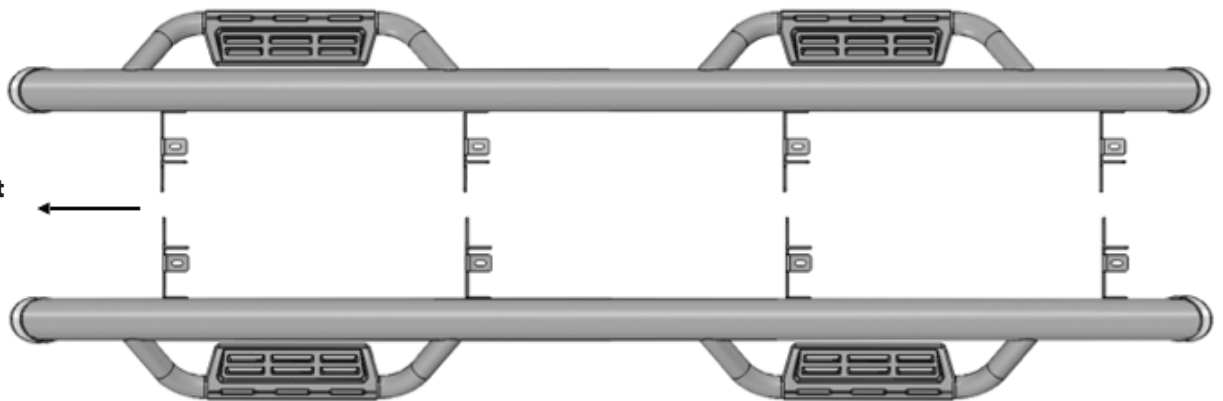
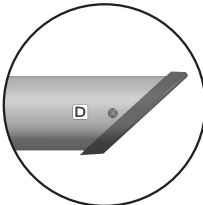

D Driver Side TYGER Access

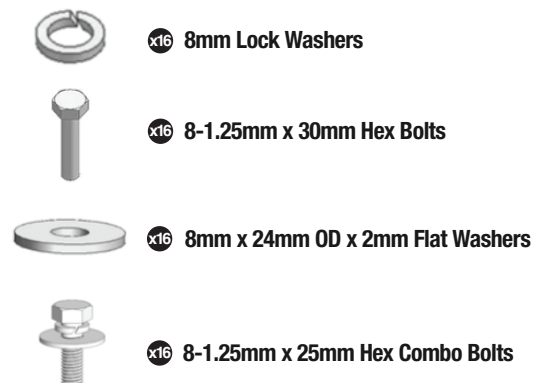
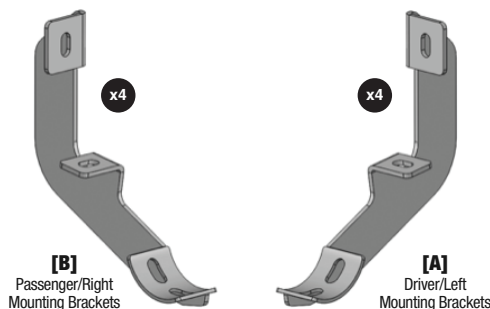

Reference the letters printed on the brackets to determine mounting locations

D Driver Side TYGER Access

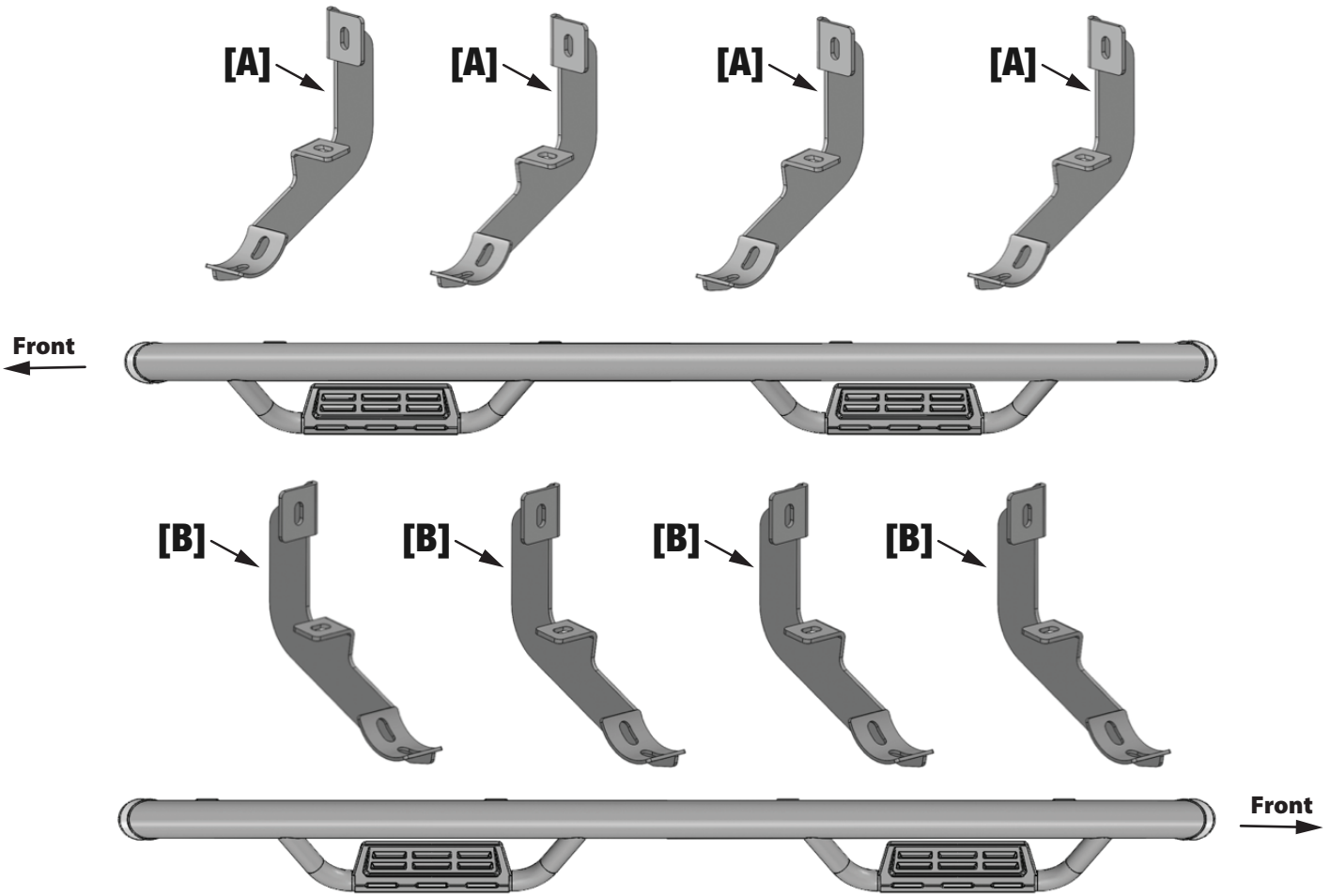

P Passenger Side TYGER Access

Bottom View

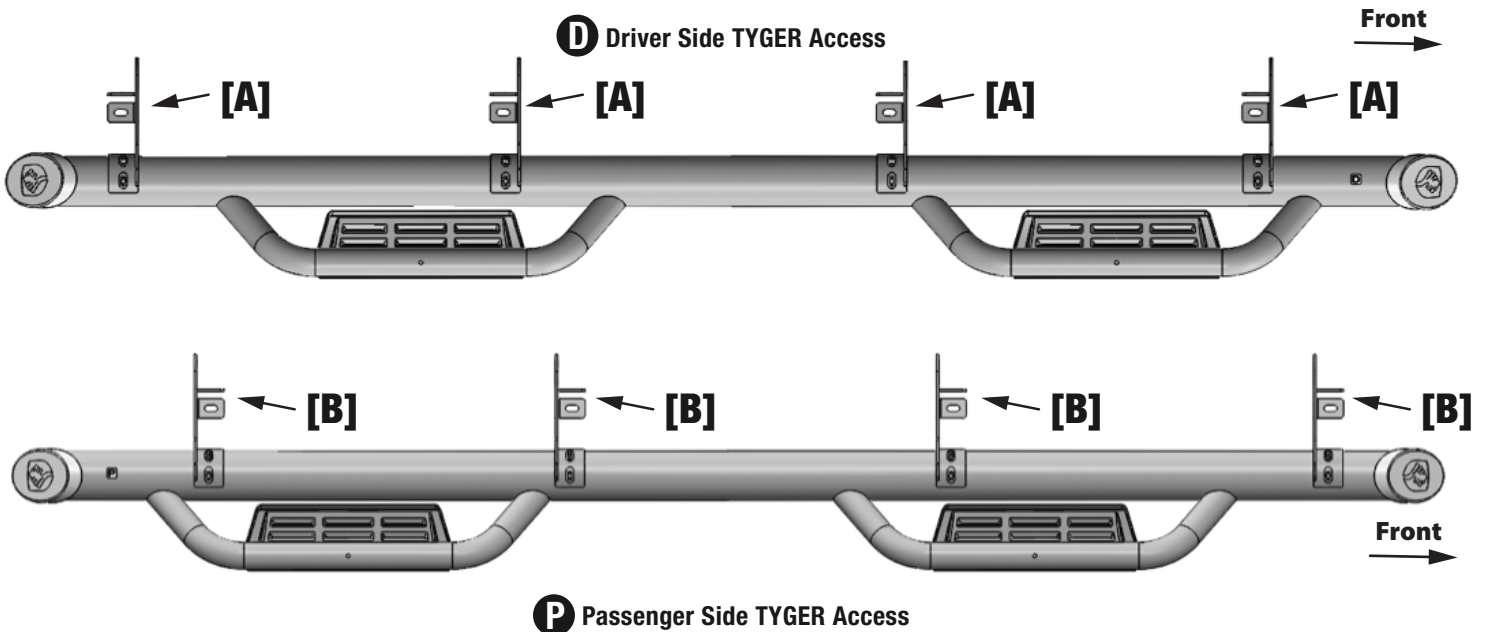

TOOLS REQUIRED

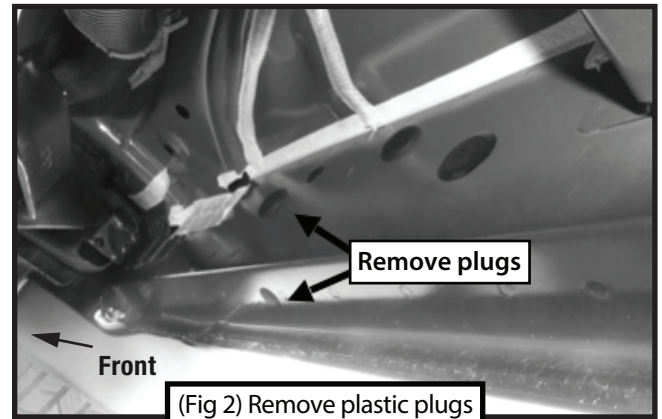
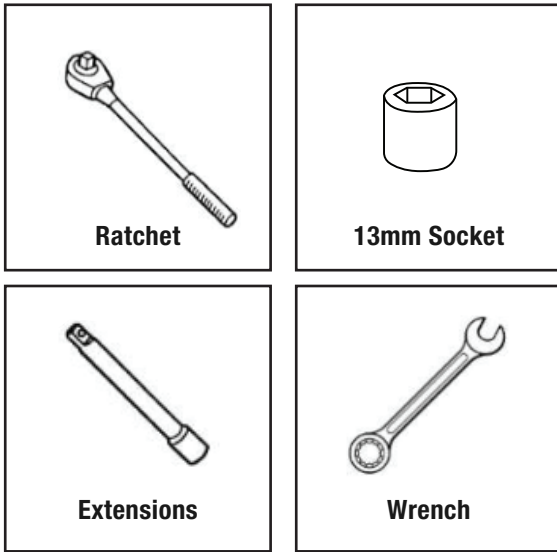

(Fig 2) Remove plastic plugs to uncover threaded inserts

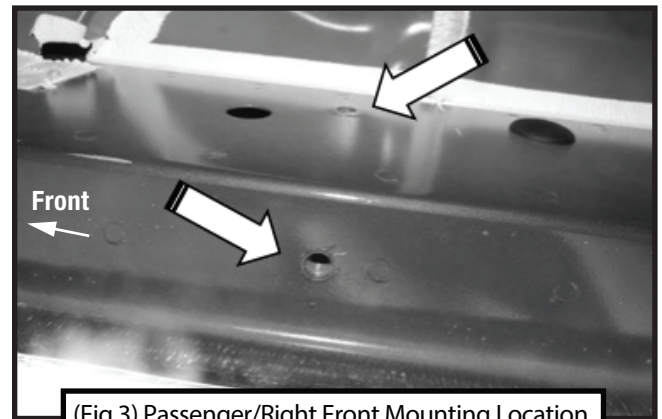

(Fig 3) Passenger/Right Front Mounting Location

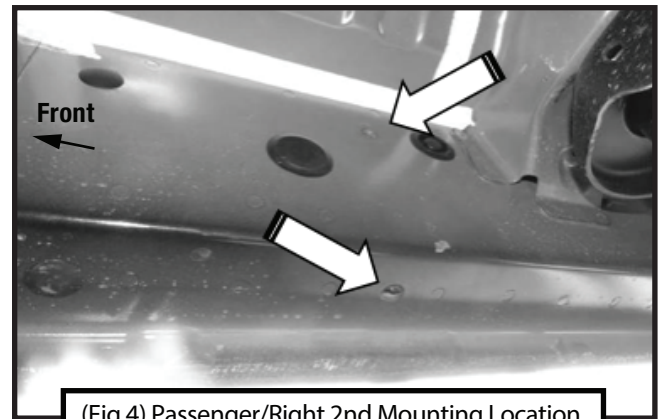

(Fig 4) Passenger/Right 2nd Mounting Location

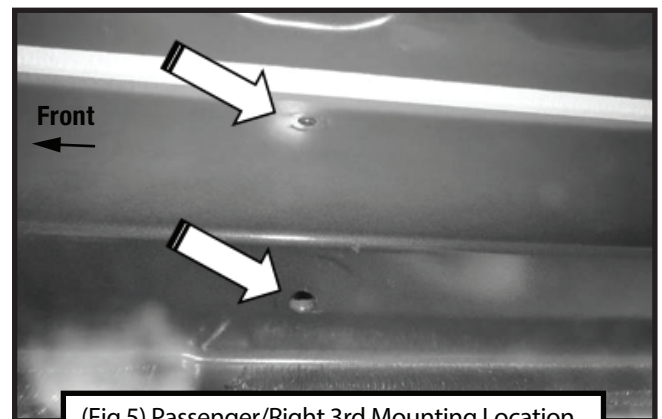

(Fig 5) Passenger/Right 3rd Mounting Location

STEP 1 MOUNTING BRACKETS

Follow (Fig 1 – 7) to attach the brackets to the Passenger/Right Side. Ensure all hardware is hand tightened at this point.

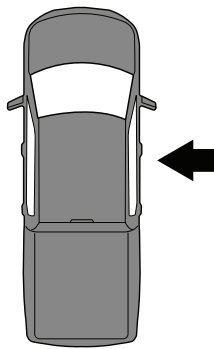

Passenger-side Mounting Area

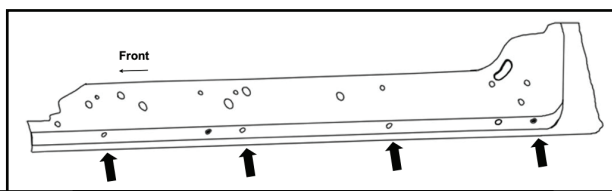

(Fig 1) Passenger/Right "Early" rocker panel mounting locations (arrows) NOTE: Hold Bracket up to body panel to help determine the correct mounting locations.

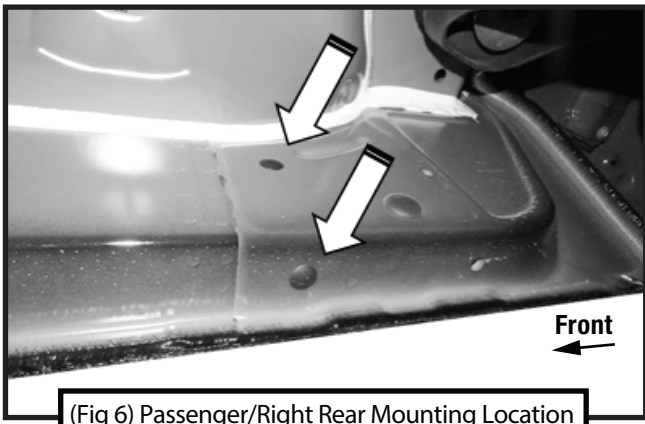

(Fig 6) Passenger/Right Rear Mounting Location

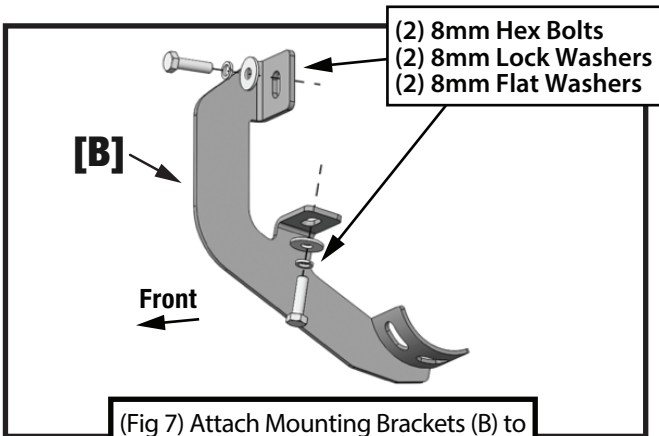

(Fig 7) Attach Mounting Brackets (B) to Passenger/Right Mounting Locations

STEP 3 DRIVER SIDE

Repeat **STEPS 1-2** for driver side installation. Use Mounting Bracket **[A]** instead of **[B]**.

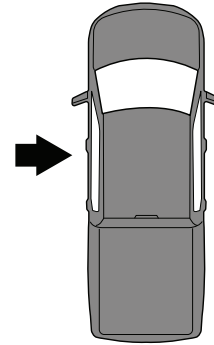

STEP 4

Ensure Tyger Access Drop Step is level and straightened, then tighten all fasteners. Installation is complete. Perform periodic inspections to the installation to make sure that all hardware is secure and tight.

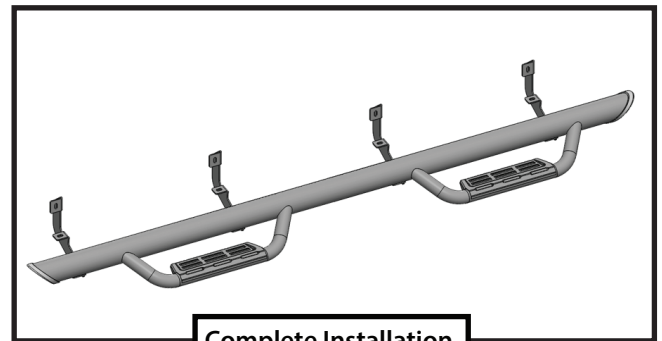

STEP 2 MOUNTING RUNNING BOARD

Follow (Fig 8) to install the Tyger Access Drop Step on the Passenger/Right Mounting Brackets. Ensure all hardware is hand tightened at this point.

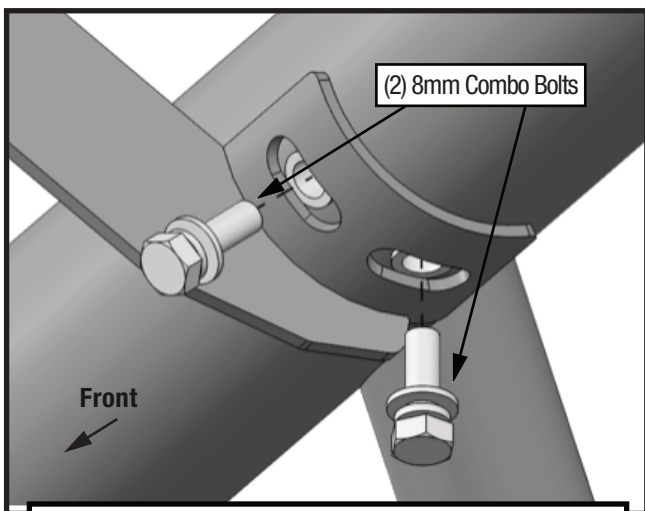

(Fig 8) Attach Passenger/Right Tyger Access Drop Step to Passenger/Right Mounting Brackets