



# TYGER ACCESS

TG-AS2C24002

Scan to Download the Latest Digital Version



## BEFORE INSTALLATION

READ INSTRUCTIONS CAREFULLY BEFORE STARTING INSTALLATION. REMOVE CONTENTS FROM BOX AND VERIFY ALL PARTS ARE PRESENT. FAILURE TO IDENTIFY DAMAGE BEFORE INSTALLATION COULD LEAD TO A REJECTION OF ANY CLAIM. IF MISSING PARTS OR ANY DAMAGE FOUND, PLEASE TAKE A PICTURE FOR THE CLAIM PURPOSE. TO FILE YOUR CLAIM, PLEASE VISIT: [WWW.TYGERAUTO.COM/CONTACT](http://WWW.TYGERAUTO.COM/CONTACT)

## TORQUE VALUES

Fastener Size	Class 8.8 Torque (ft-lbs)	Class 10.9 Torque (ft-lbs)
6mm	6-7	6-7
8mm	15-16	22-23
10mm	31-32	44-45
12mm	54-55	78-79
14mm	87-88	125-126

- x1** Driver/Left Tyger Access
- x1** Passenger/Right Tyger Access
- x3** Driver/Left Mounting Brackets [A]
- x3** Passenger/Right Mounting Brackets [B]
- x12** 8mm Lock Washers
- x12** 8mm Clip Nuts
- x12** 8mm x 24mm OD x 2mm Flat Washers
- x12** 8-1.25mm x 30mm Hex Bolts
- x12** 8-1.25mm x 25mm Hex Combo Bolts

## Parts List

### Top View

**ATTENTION:** Refer to **D** and **P** labelling on the side of the tubes to determine Driver and Passenger TYGER Access

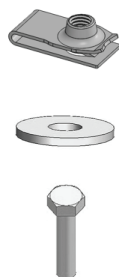
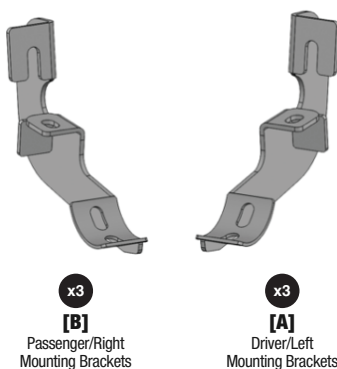
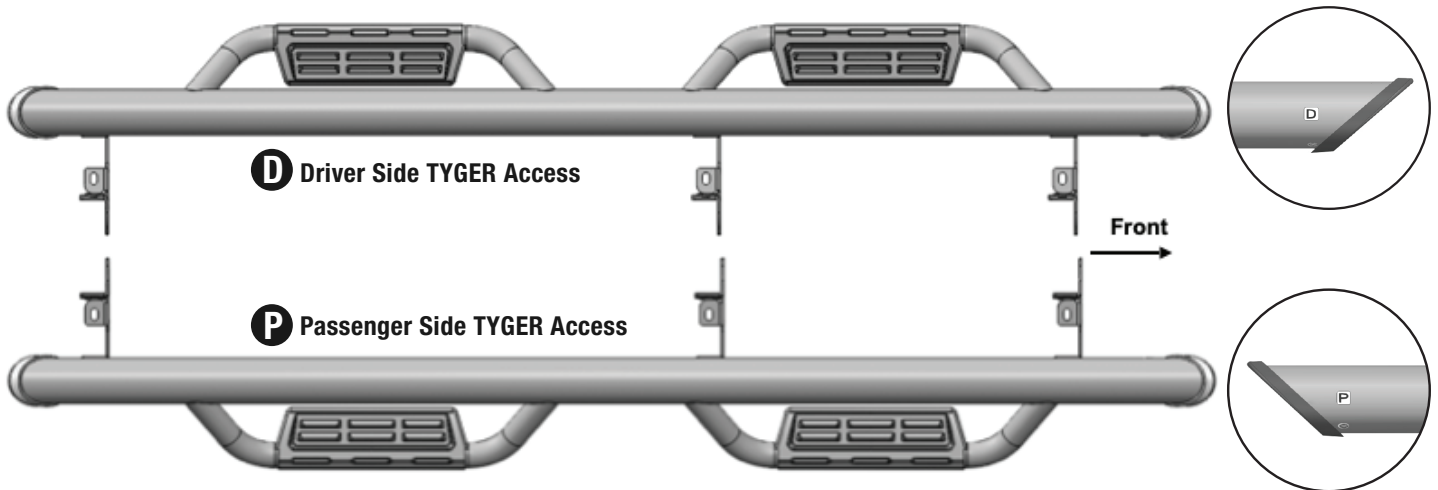

**x12** 8mm Clip Nuts

**x12** 8mm x 24mm OD x 2mm Flat Washers

**x12** 8-1.25mm x 30mm Hex Bolts



**x12** 8mm Lock Washers



**x12** 8-1.25mm x 25mm Hex Combo Bolts

Reference the letters printed on the brackets to determine mounting locations

**D** Driver Side TYGER Access

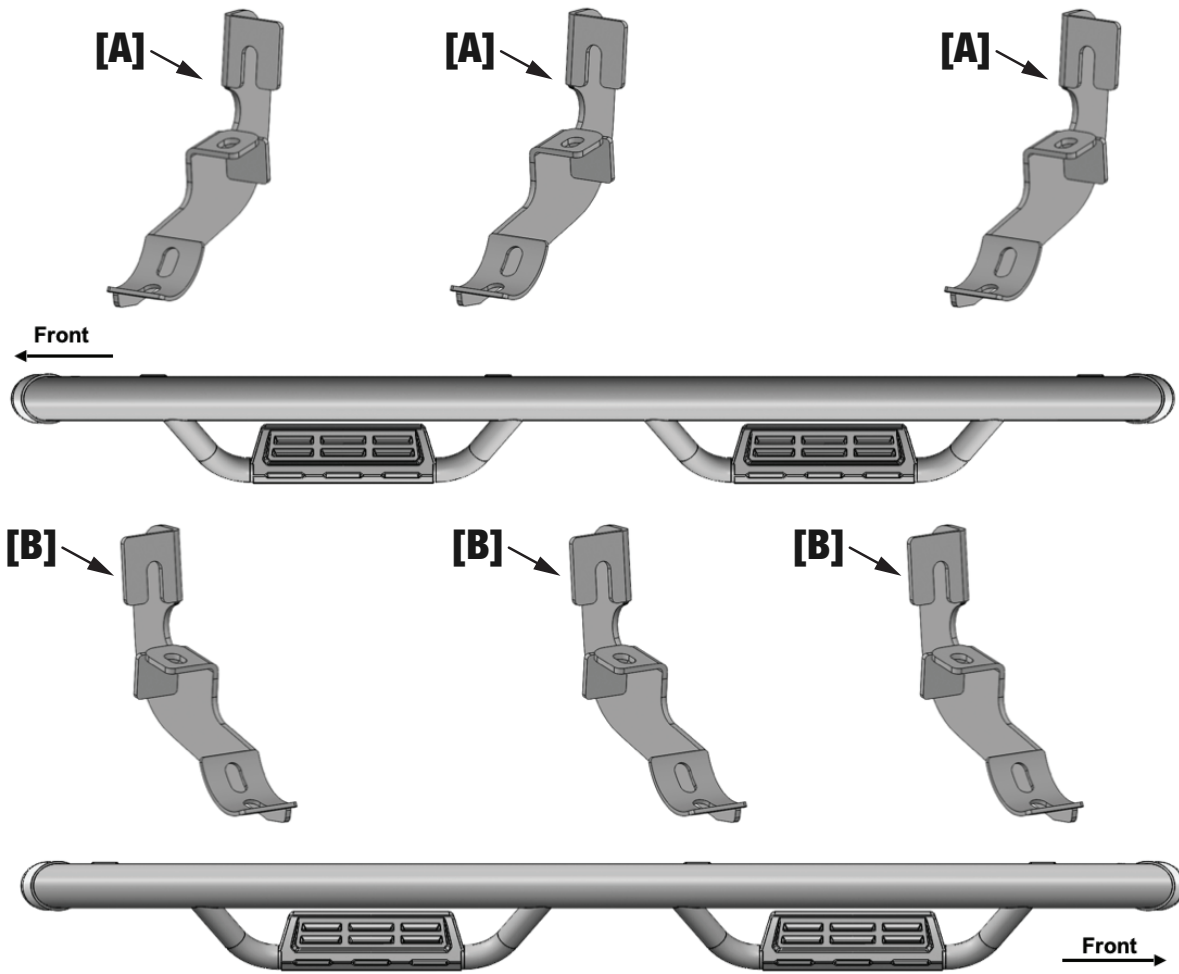

**P** Passenger Side TYGER Access

**Bottom View**

**D** Driver Side TYGER Access

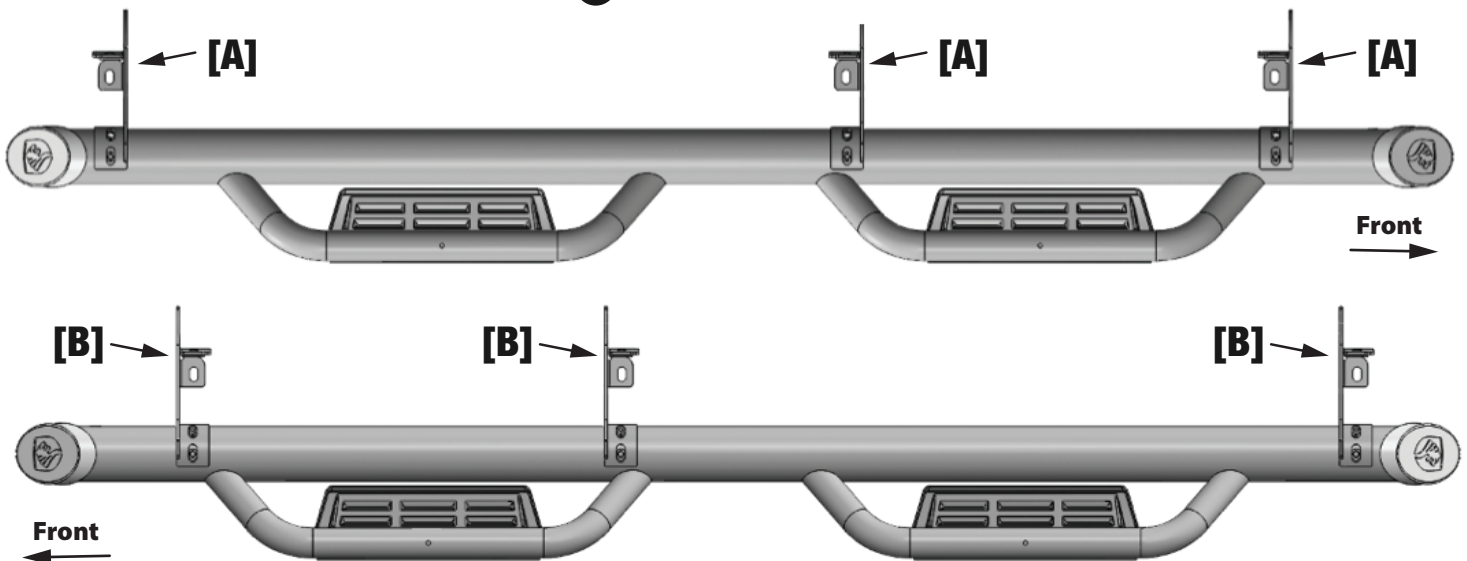

**P** Passenger Side TYGER Access

## TOOLS REQUIRED

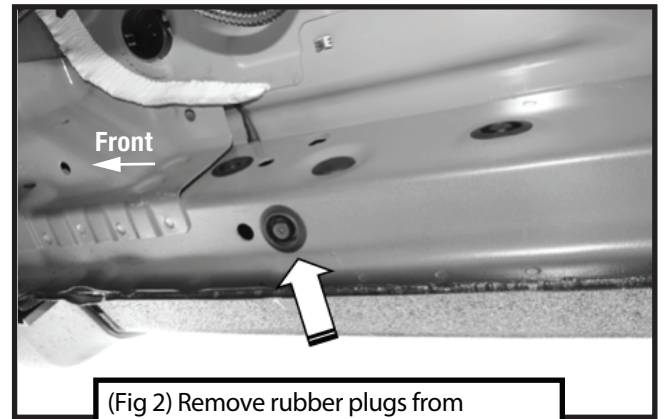
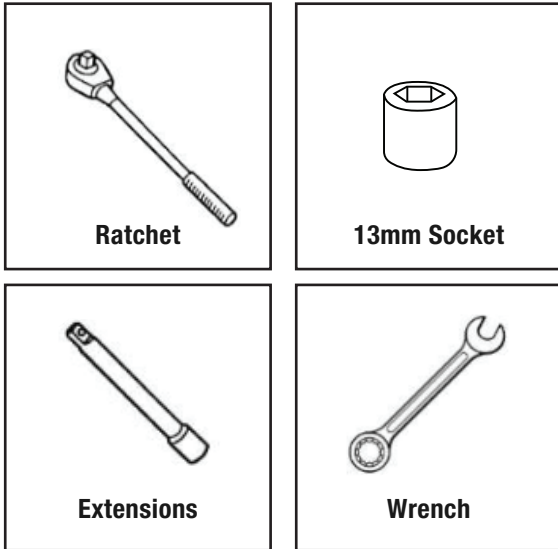

(Fig 2) Remove rubber plugs from Passenger/Right Front Mounting Location

## STEP 1 MOUNTING BRACKETS

Follow (Fig 1 – 8) to attach the brackets to the Passenger/Right Side. Ensure all hardware is hand tightened at this point.

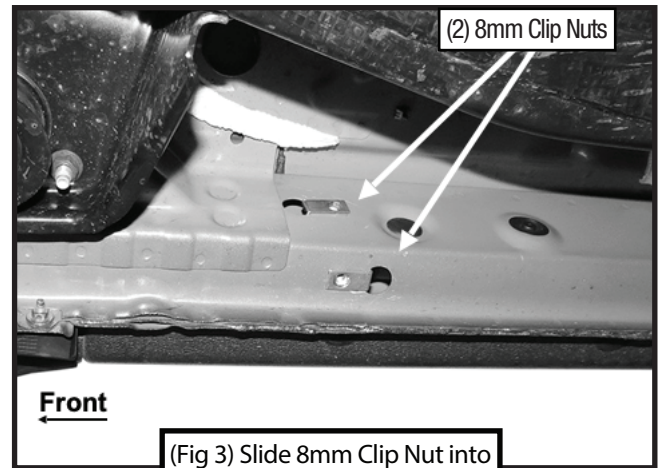
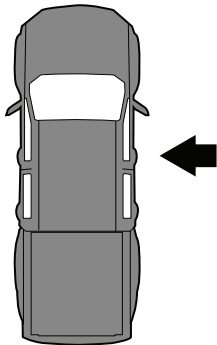

(Fig 3) Slide 8mm Clip Nut into large hole and over small hole

 **Passenger-side Front Mounting Area**

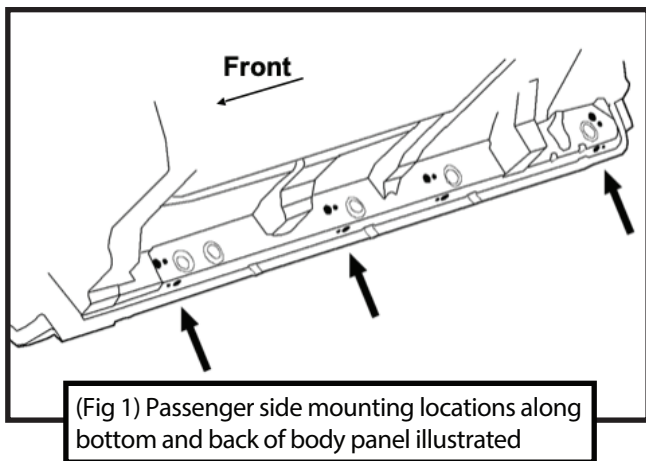

(Fig 1) Passenger side mounting locations along bottom and back of body panel illustrated

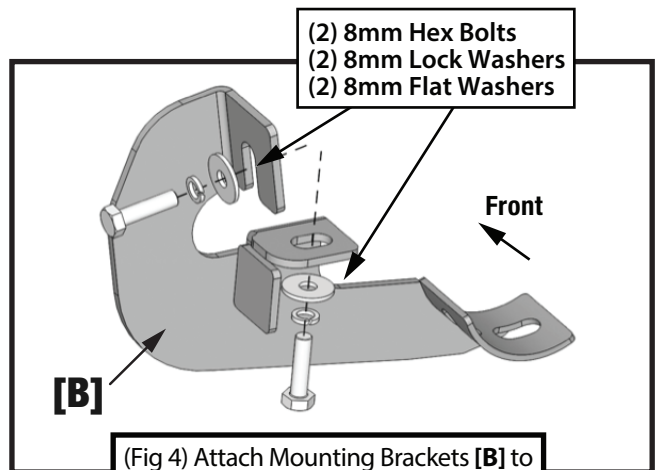

(Fig 4) Attach Mounting Brackets [B] to Passenger/Right Mounting Location

**Passenger-side Center Mounting Area**

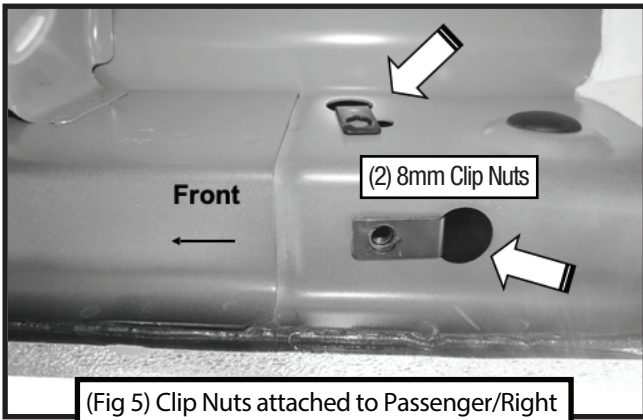

(Fig 5) Clip Nuts attached to Passenger/Right Center Mounting Location

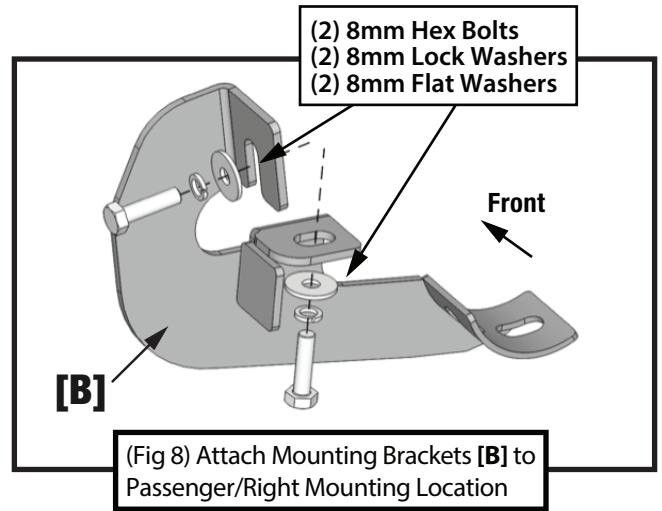

(Fig 8) Attach Mounting Brackets [B] to Passenger/Right Mounting Location

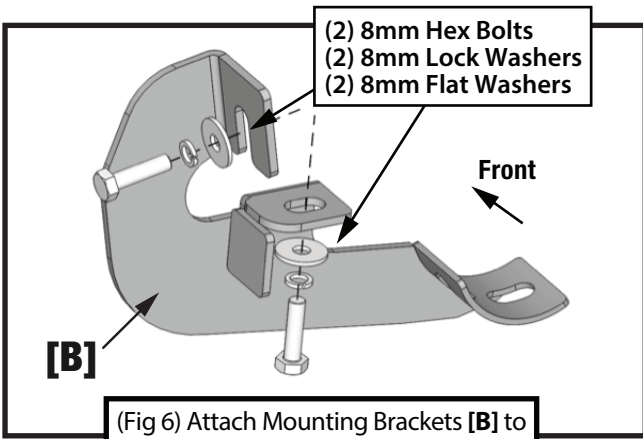

(Fig 6) Attach Mounting Brackets [B] to Passenger/Right Mounting Location

**Passenger-side Rear Mounting Area**

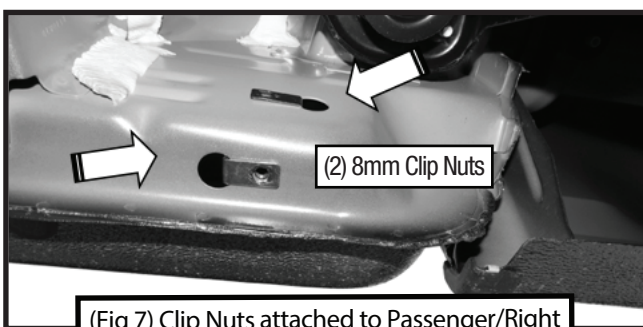

(Fig 7) Clip Nuts attached to Passenger/Right Rear Mounting Location

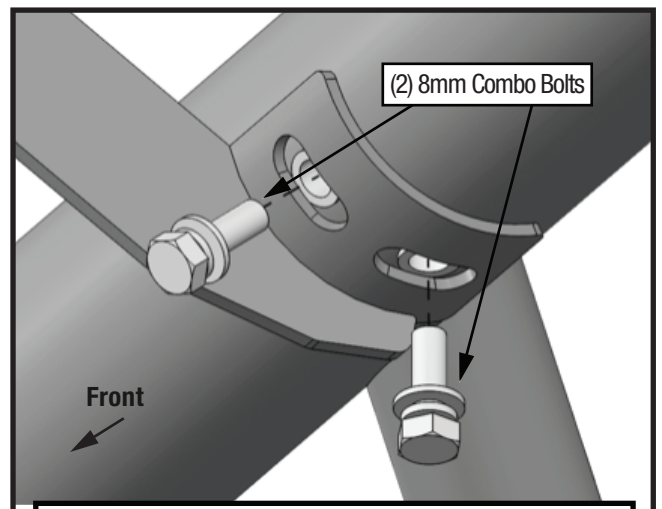

(Fig 9) Attach Passenger/Right Tyger Access Drop Step to Passenger/Right Mounting Brackets

**STEP 2 MOUNTING RUNNING BOARD**

Follow (Fig 9) to install the Tyger Access Drop Step on the Passenger/Right Mounting Brackets. Ensure all hardware is hand tightened at this point.

### STEP 3 DRIVER SIDE

Repeat **STEPS 1-2** for driver side installation.  
Use Mounting Brackets **[A]** instead of **[B]**.

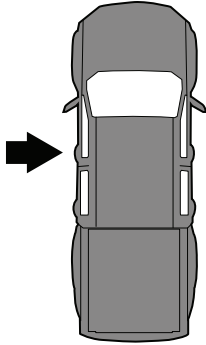

### STEP 4

Ensure Tyger Access Drop Step is level and straightened, then tighten all fasteners. Installation is complete. Perform periodic inspections to the installation to make sure that all hardware is secure and tight.

