



# TYGER ACCESS

TG-AS2D24005

Scan to Download the Latest Digital Version



## BEFORE INSTALLATION

READ INSTRUCTIONS CAREFULLY BEFORE STARTING INSTALLATION. REMOVE CONTENTS FROM BOX AND VERIFY ALL PARTS ARE PRESENT. FAILURE TO IDENTIFY DAMAGE BEFORE INSTALLATION COULD LEAD TO A REJECTION OF ANY CLAIM. IF MISSING PARTS OR ANY DAMAGE FOUND, PLEASE TAKE A PICTURE FOR THE CLAIM PURPOSE. TO FILE YOUR CLAIM, PLEASE VISIT: [WWW.TYGERAUTO.COM/CONTACT](http://WWW.TYGERAUTO.COM/CONTACT)

## TORQUE VALUES

Fastener Size	Class 8.8 Torque (ft-lbs)	Class 10.9 Torque (ft-lbs)
6mm	6-7	6-7
8mm	15-16	22-23
10mm	31-32	44-45
12mm	54-55	78-79
14mm	87-88	125-126

- x1** Driver/Left Tyger Access
- x12** 8-1.25mm x 25mm Hex Combo Bolts
- x6** 8mm Lock Washers
- x1** Passenger/Right Tyger Access
- x24** 6mm x 22mm x 2mm Flat Washers
- x3** Driver/Left Mounting Brackets [A]
- x12** 6-1.0mm x 25mm Hex Bolts
- x3** Passenger/Right Mounting Brackets [B]
- x12** 6mm Nylon Lock Nuts
- x3** Driver/Left Support Brackets [F]
- x12** 8-1.25mm x 30mm Hex Bolts
- x3** Passenger/Right Support Brackets [E]
- x18** 8mm x 24mm x 2mm Flat Washers
- x6** 8-1.25mm x 30mm Button Head Bolt Plates
- x6** 8mm Nylon Lock Nuts
- x6** 8mm Plastic Retainers
- x6** 8mm Hex Nuts

## Parts List

### Top View

**ATTENTION:** Refer to **D** and **P** labelling on the side of the tubes to determine Driver and Passenger TYGER Access

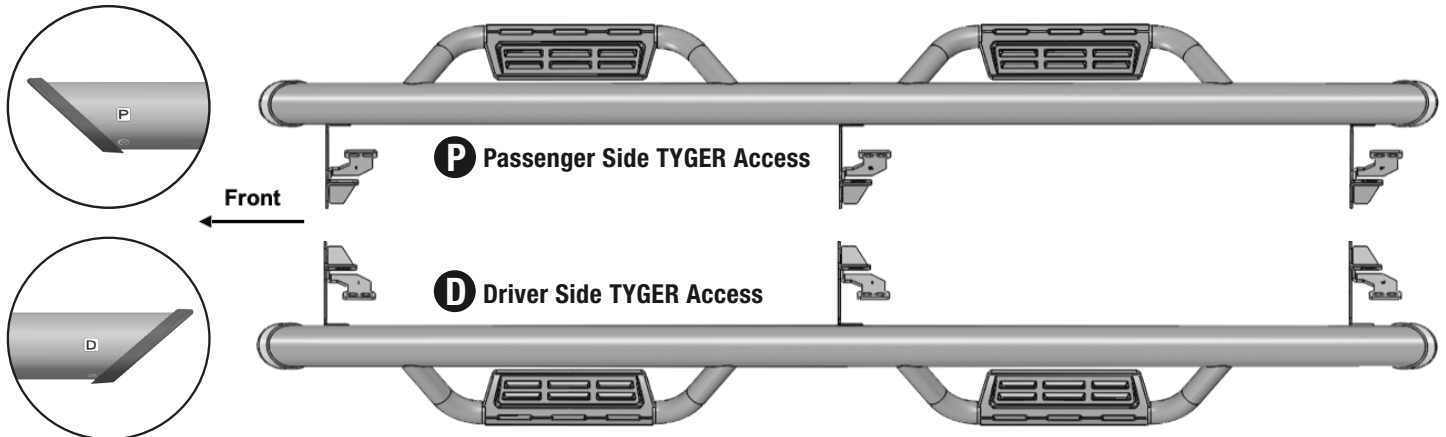

- x3** [A] Driver/Left Mounting Brackets
- x3** [B] Passenger/Right Mounting Brackets
- x6** 8mm Plastic Retainers
- x6** 8-1.25mm x 30mm Button Head Bolt Plates
- x12** 8-1.25mm x 25mm Hex Combo Bolts
- x24** 6mm x 22mm x 2mm Flat Washers
- x12** 6-1.0mm x 25mm Hex Bolts
- x12** 6mm Nylon Lock Nuts
- x18** 8mm x 24mm x 2mm Flat Washers
- x12** 8-1.25mm x 30mm Hex Bolts
- x6** 8mm Nylon Lock Nuts
- x3** [F] Driver/Left Support Brackets
- x3** [E] Passenger/Right Support Brackets
- x6** 8mm Lock Washers
- x6** 8mm Hex Nuts

Reference the letters printed on the brackets to determine mounting locations

**Top View**

**D** Driver Side TYGER Access

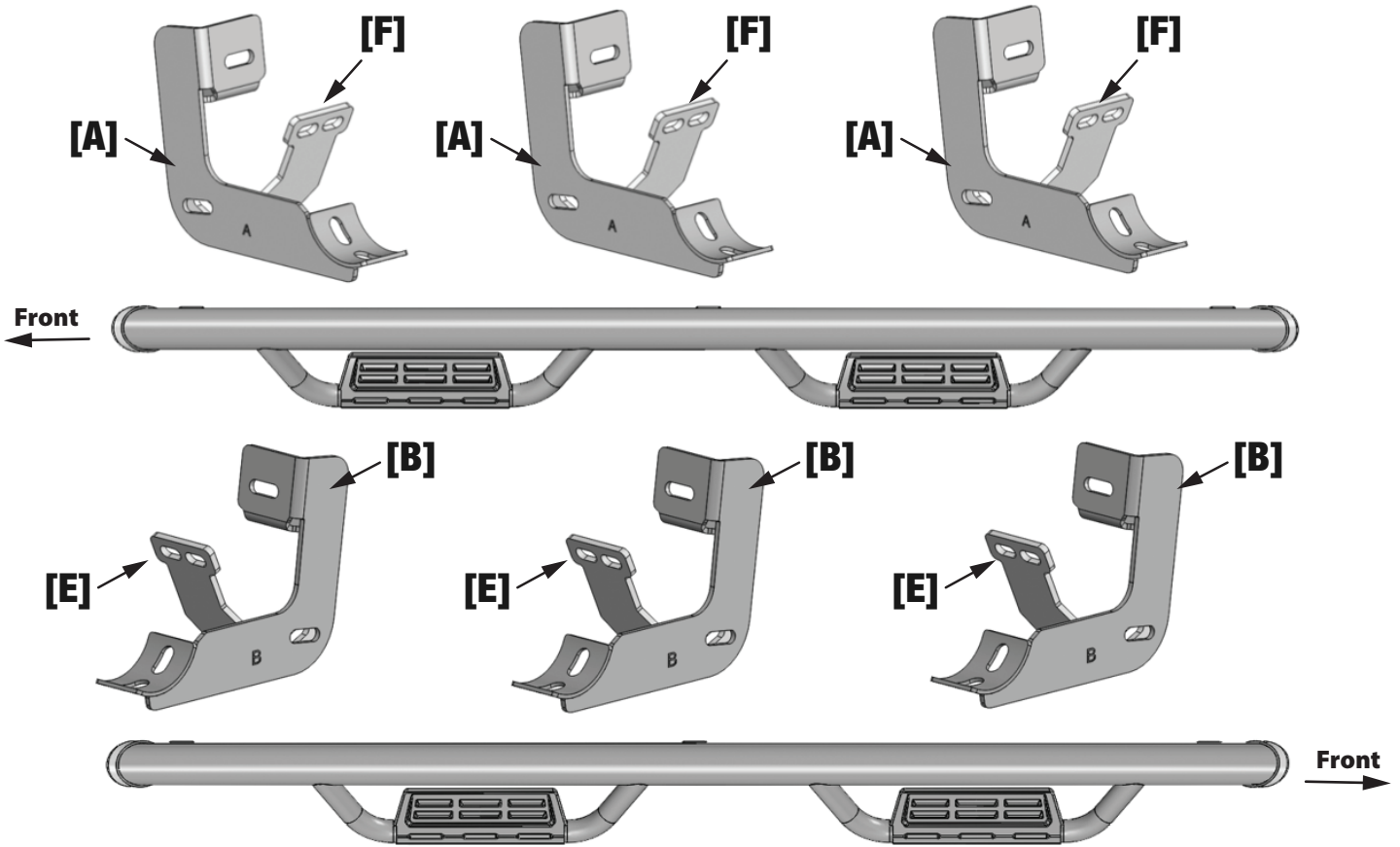

**P** Passenger Side TYGER Access

**Bottom View**

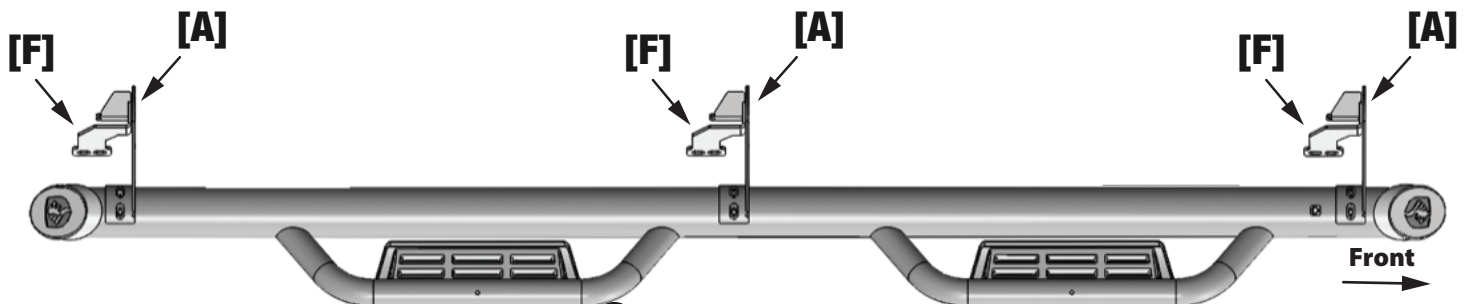

**D** Driver Side TYGER Access

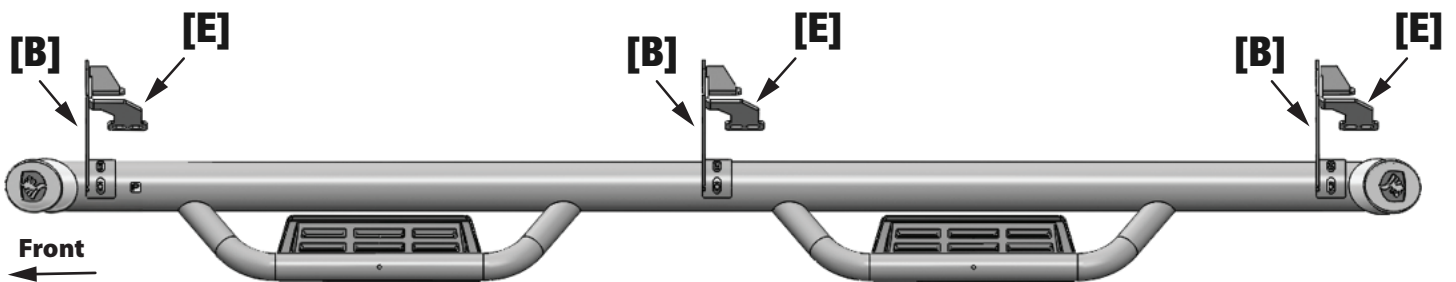

**P** Passenger Side TYGER Access

## TOOLS REQUIRED

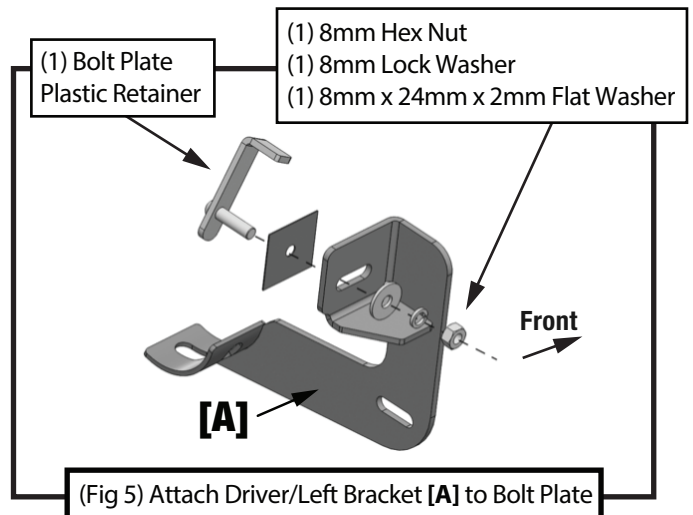
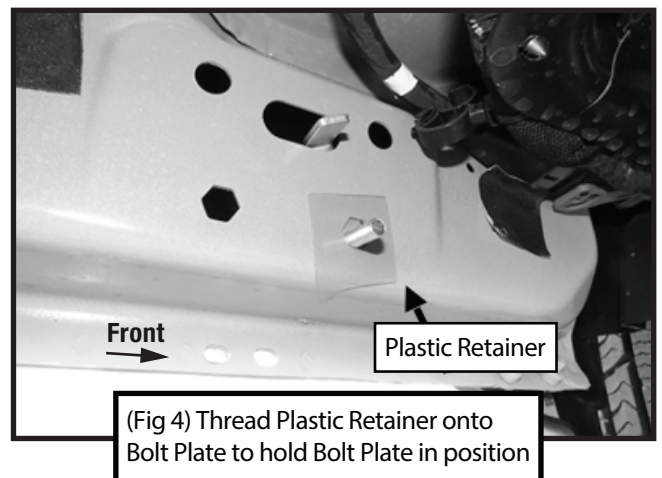
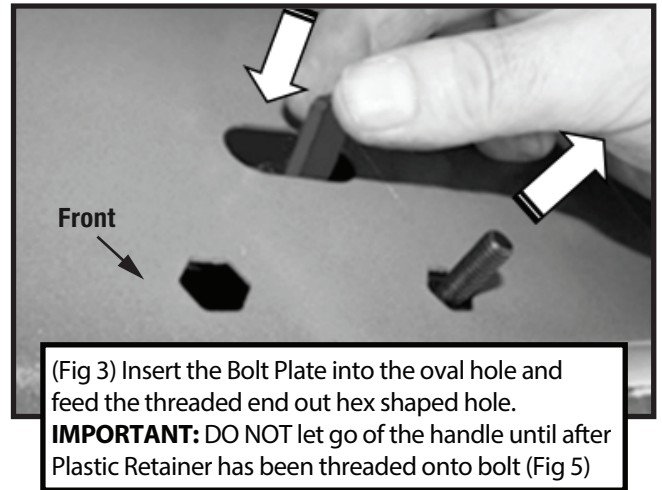
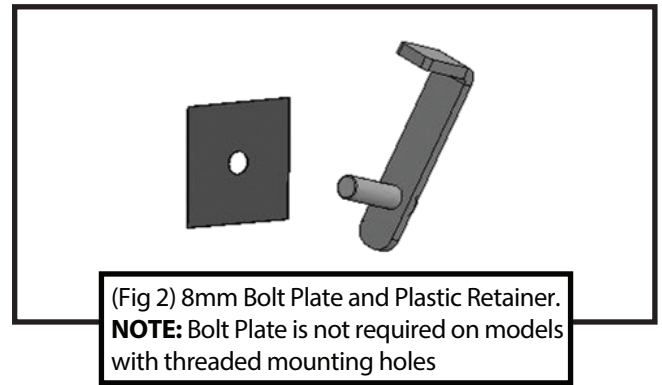
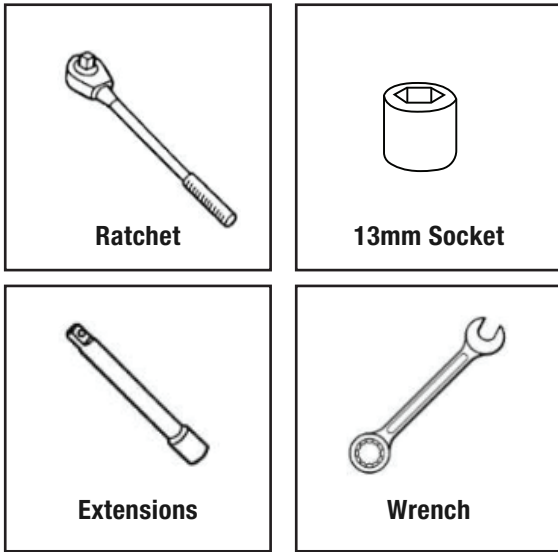

## STEP 1 MOUNTING BRACKETS

Follow (Fig 1 – 13) to attach Mounting Brackets to the Driver/Left Side starting at Front. Then add Support Brackets to Mounting Brackets. Ensure hardware is hand tightened.

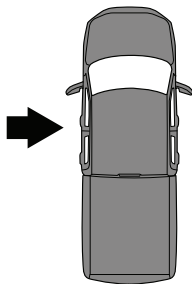

### Driver-side Front Mounting Area

For model years **2009-mid 2015:**

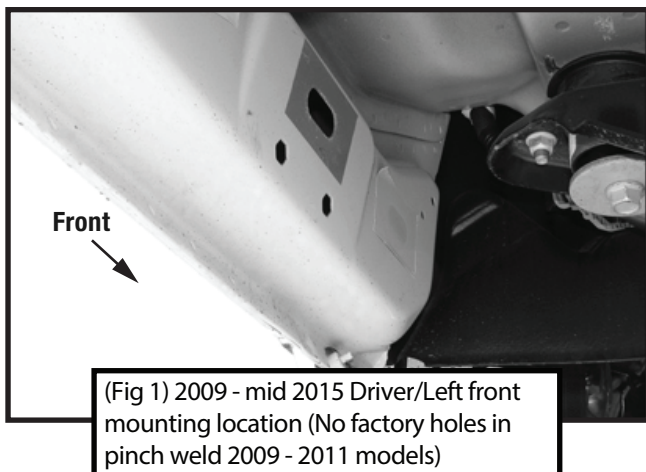

For model years **Mid 2015 - on:**

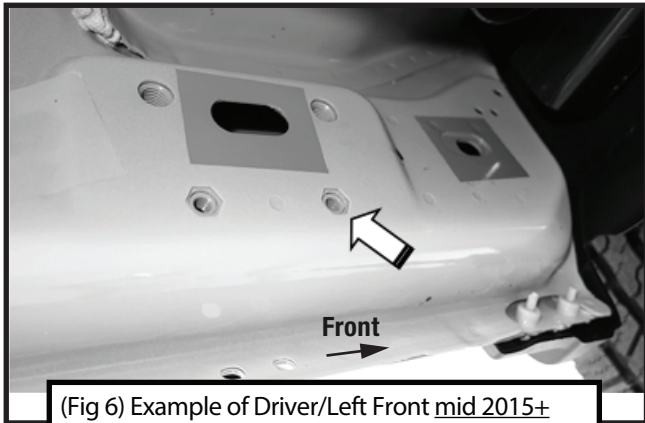

(Fig 6) Example of Driver/Left Front mid 2015+ mounting location with factory installed threaded mounting holes

- (1) 8-1.25mm x 30mm Hex Bolt
- (1) 8mm Lock Washer
- (1) 8mm x 24mm x 2mm Flat Washer

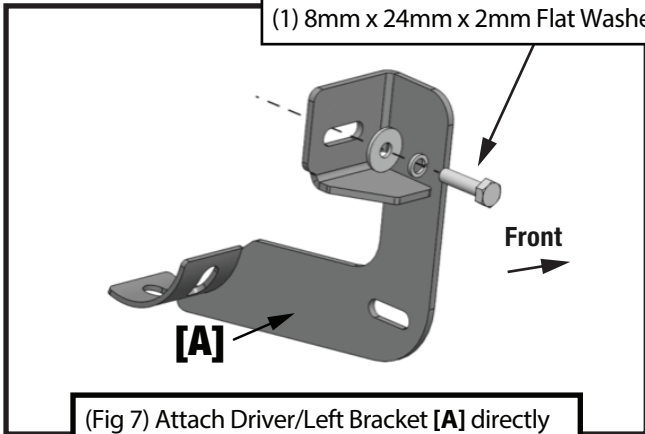

(Fig 7) Attach Driver/Left Bracket [A] directly to threaded holes in mounting location (Fig 6)

- (1) 8-1.25mm x 30mm Hex Bolt
- (2) 8mm x 24mm x 2mm Flat Washers
- (1) 8mm Nylon Lock Washer

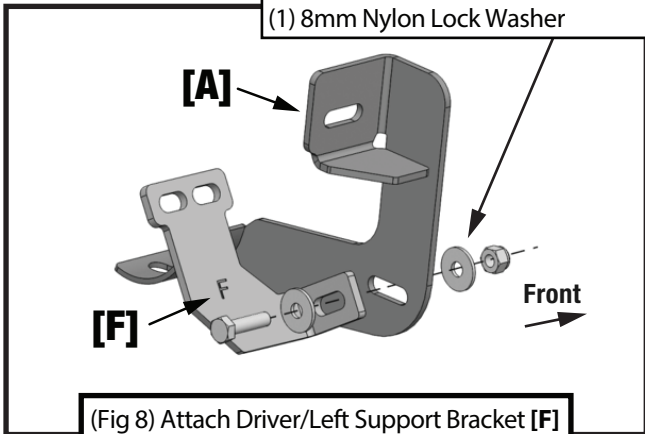

(Fig 8) Attach Driver/Left Support Bracket [F] to rear facing side of Mounting Bracket [A]

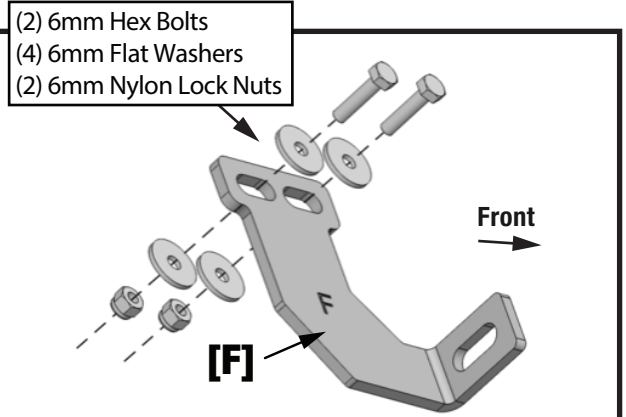

(Fig 9) Attach Support Bracket [F] to back of pinch weld (models with factory holes in pinch weld only)

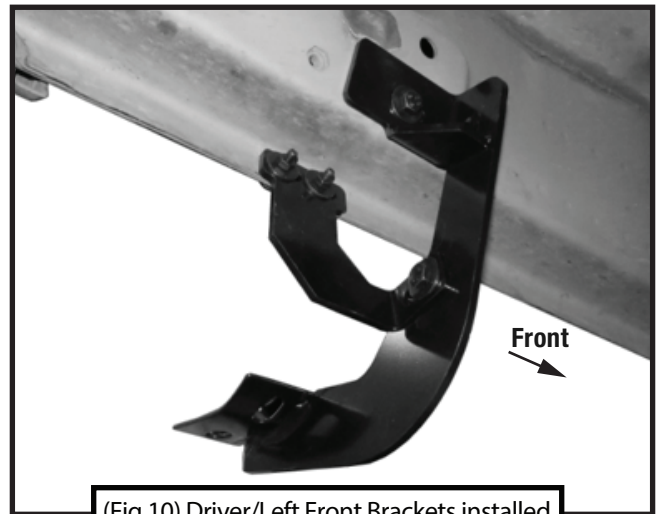

(Fig 10) Driver/Left Front Brackets installed



**Driver-side Center Mounting Area**

Repeat (Fig 1-10) to install Driver/Left Mounting [A] and Supporting [F] Brackets to center mounting location.

For model years **2009-mid 2015:**

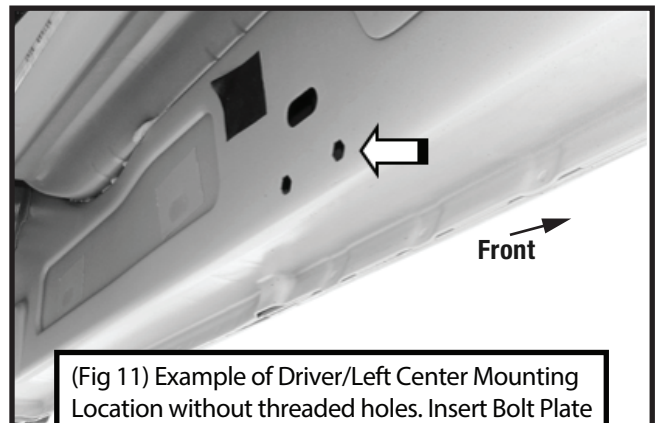

(Fig 11) Example of Driver/Left Center Mounting Location without threaded holes. Insert Bolt Plate into oval hole and out forward hex hole (arrow). Also see (Fig 3 & 4)

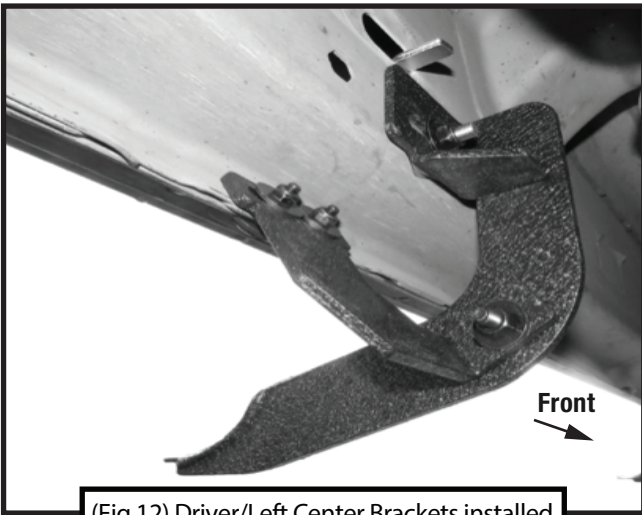

(Fig 12) Driver/Left Center Brackets installed

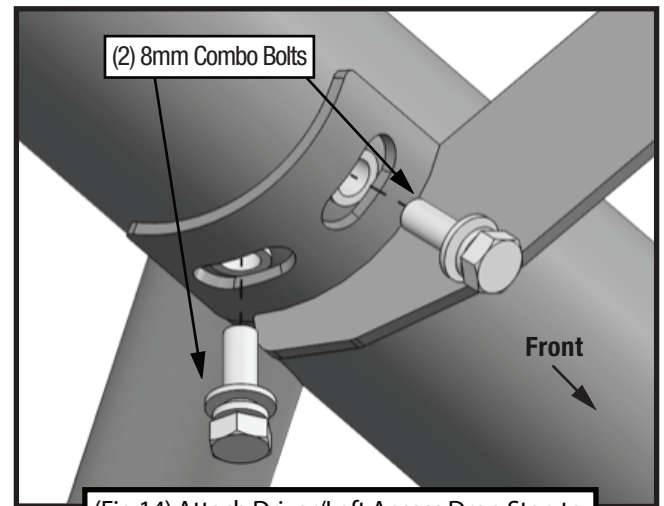

(Fig 14) Attach Driver/Left Access Drop Step to Driver/Left Mounting Brackets



**Driver-side Rear Mounting Area**

Repeat (Fig 1-10) to install Driver/Left Mounting **[A]** and Supporting **[F]** Brackets to rear mounting location.

**For model years 2009-mid 2015:**

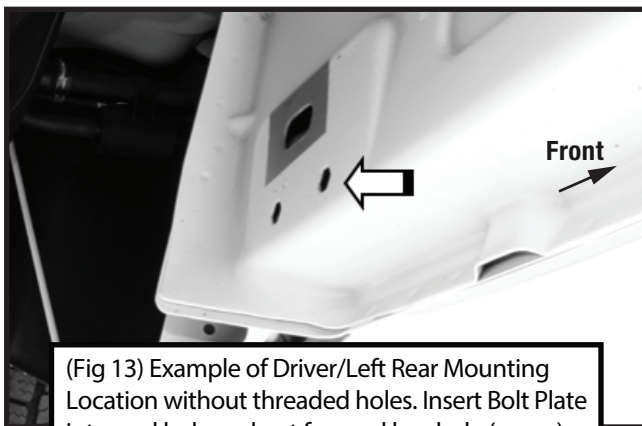

(Fig 13) Example of Driver/Left Rear Mounting Location without threaded holes. Insert Bolt Plate into oval hole and out forward hex hole (arrow). Also see (Fig 3 & 4)

**IMPORTANT: 2009-2012 models without holes in pinch weld will require drilling 1/4" holes through pinch weld to attach support bracket. Complete installation and level Drop Step before drilling holes for support brackets.**

**STEP 2 MOUNTING RUNNING BOARD**

Follow (Fig 14) to install the Access Drop Step on the Driver/Left Side. Repeat the following steps on the Passenger/Right. Ensure all hardware is hand tightened at this point.

**STEP 3 PASSENGER SIDE**

Repeat **STEPS 1-2** for passenger side installation. Use Mounting Brackets **[B]** instead of **[A]**; Use Support Brackets **[E]** instead of **[F]**.

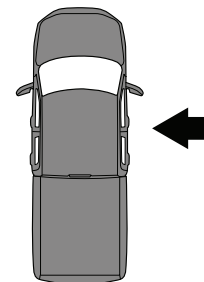

**STEP 4 COMPLETION**

Ensure Tyger Access Drop Step is level and straightened, then tighten all fasteners. Installation is complete. Perform periodic inspections to the installation to make sure that all hardware is secure and tight.

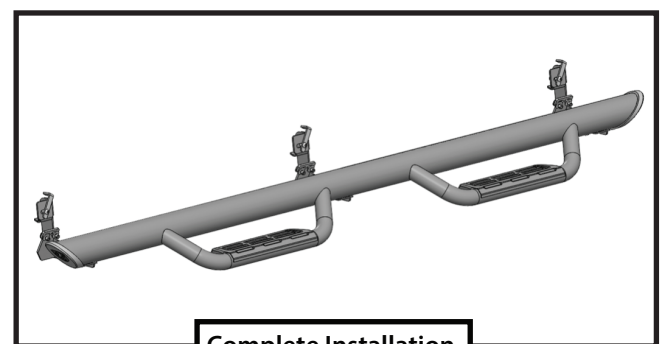

Complete Installation