



TYGER ACCESS

TG-AS2D24008

Scan to Download the Latest Digital Version



BEFORE INSTALLATION

READ INSTRUCTIONS CAREFULLY BEFORE STARTING INSTALLATION. REMOVE CONTENTS FROM BOX AND VERIFY ALL PARTS ARE PRESENT. FAILURE TO IDENTIFY DAMAGE BEFORE INSTALLATION COULD LEAD TO A REJECTION OF ANY CLAIM. IF MISSING PARTS OR ANY DAMAGE FOUND, PLEASE TAKE A PICTURE FOR THE CLAIM PURPOSE. TO FILE YOUR CLAIM, PLEASE VISIT: WWW.TYGERAUTO.COM/CONTACT

TORQUE VALUES

Fastener Size	Class 8.8 Torque (ft-lbs)	Class 10.9 Torque (ft-lbs)
6mm	6-7	6-7
8mm	15-16	22-23
10mm	31-32	44-45
12mm	54-55	78-79
14mm	87-88	125-126

- x1** Driver/Left Tyger Access
- x1** Passenger/Right Tyger Access
- x4** Front and Rear Mounting Brackets [A]
- x4** Front and Rear Support Brackets [F]
- x2** Center Front Brackets [B]
- x2** Center Support Brackets [D]
- x20** 8mm x 24mm x 2mm Flat Washers
- x28** 8mm Nylon Lock Nuts
- x16** 8mm x 16mm x 1.6mm Flat Washers
- x8** 8-1.25 x 25mm Hex Bolts
- x12** 8-1.25 x 25mm Hex Combo Bolts

Parts List

Top View

ATTENTION: Refer to **D** and **P** labelling on the side of the tubes to determine Driver and Passenger TYGER Access

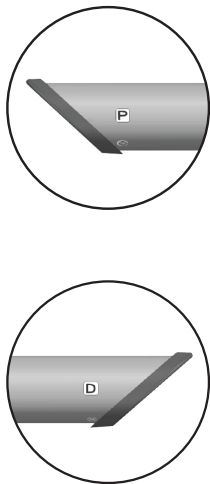

P Passenger Side TYGER Access

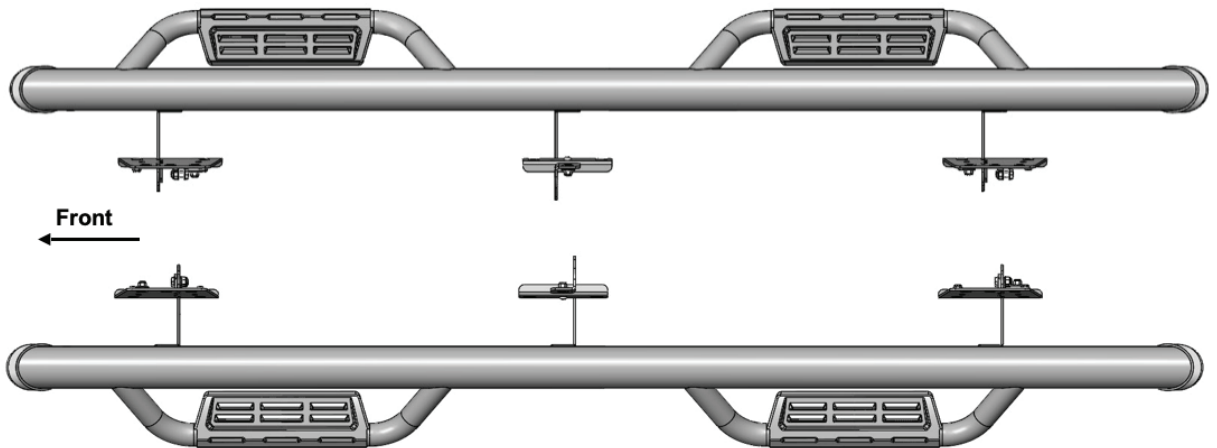

D Driver Side TYGER Access



Reference the letters printed on the brackets to determine mounting locations

Top View

D Driver Side TYGER Access

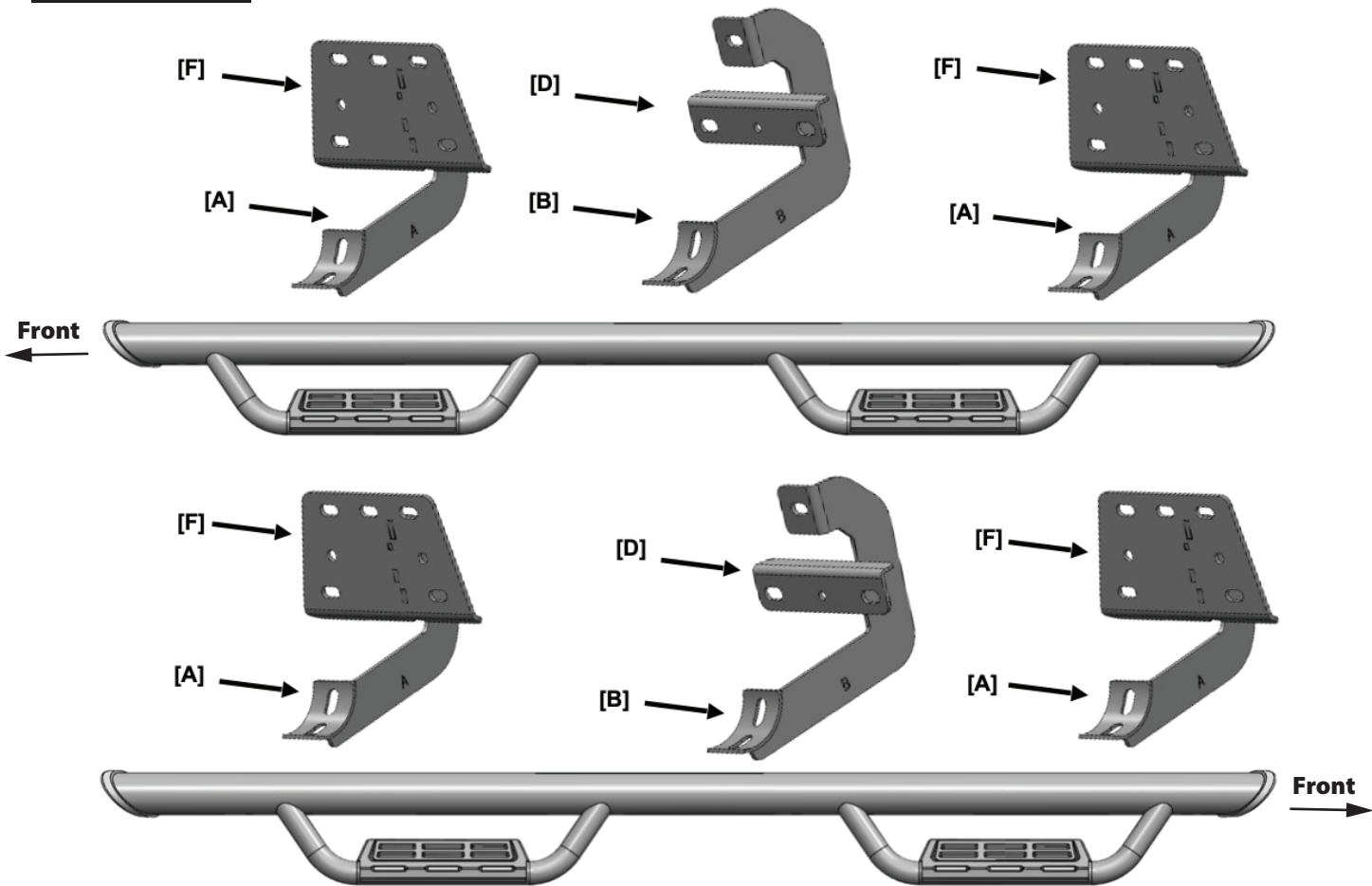

P Passenger Side TYGER Access

Bottom View

D Driver Side TYGER Access

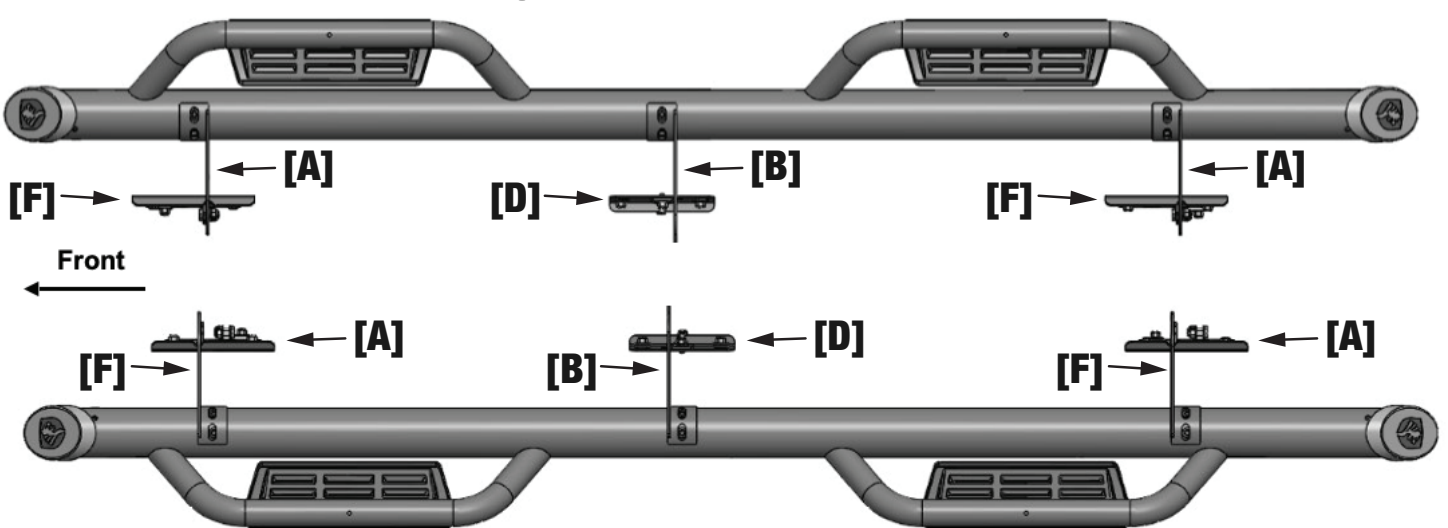

P Passenger Side TYGER Access

TOOLS REQUIRED

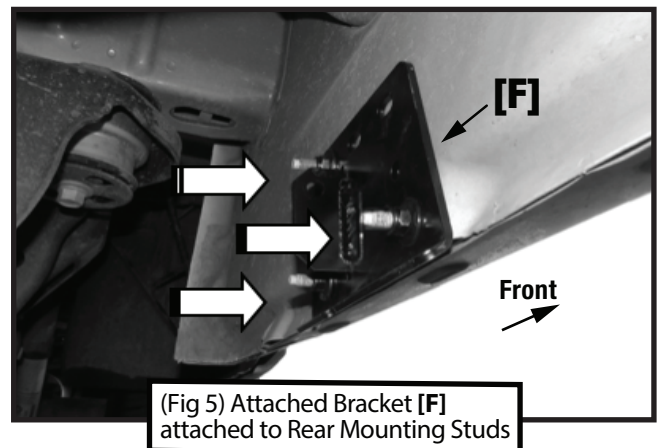
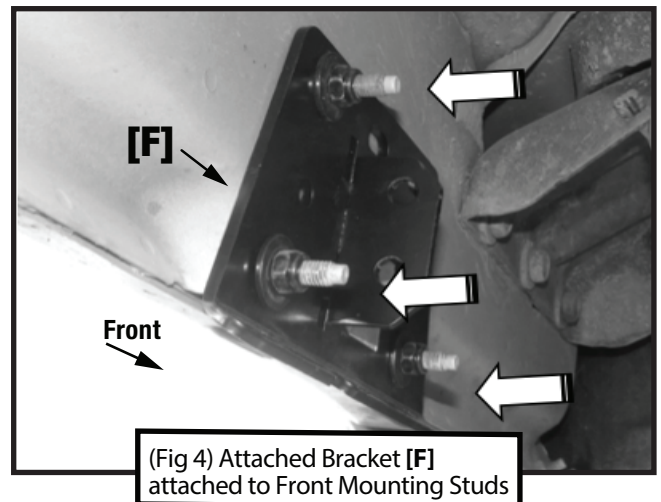
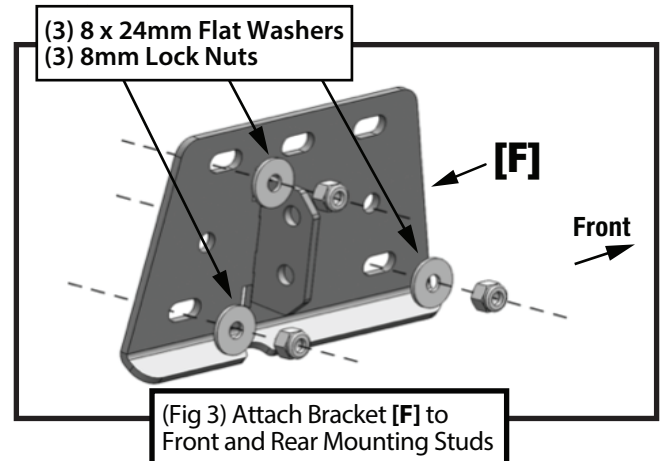
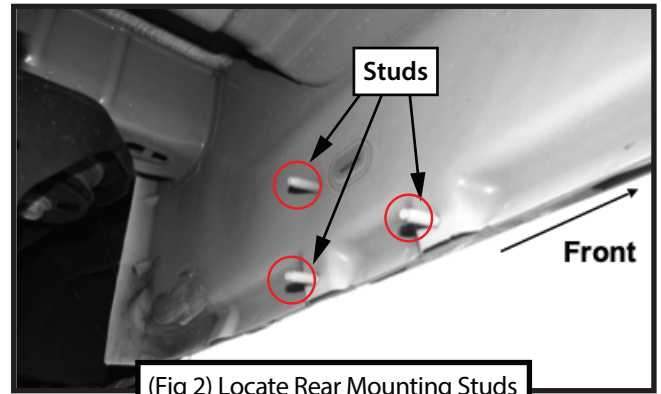
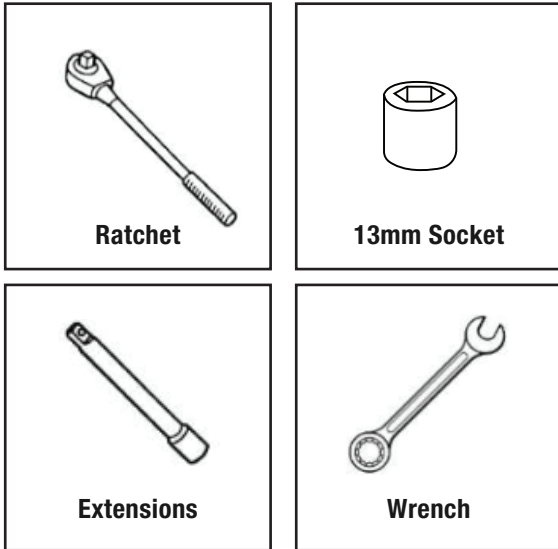

STEP 1 MOUNTING BRACKETS

Follow (Fig 1 – 13) to attach the Mounting Brackets to the Driver/Left Side. Ensure hardware is hand tightened at this point.

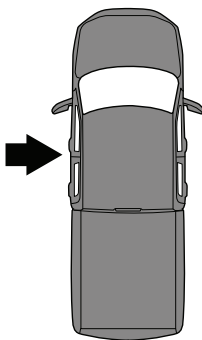

Driver-side Front & Rear Mounting Area

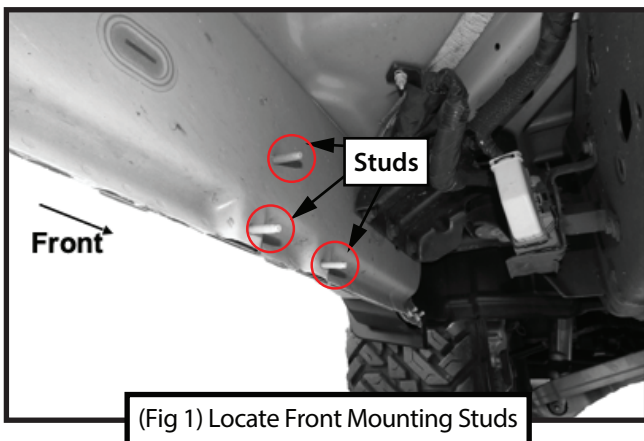

- (2) 8mm Hex Bolts
- (4) 8 x 16mm Flat Washers
- (2) 8mm Lock Nuts

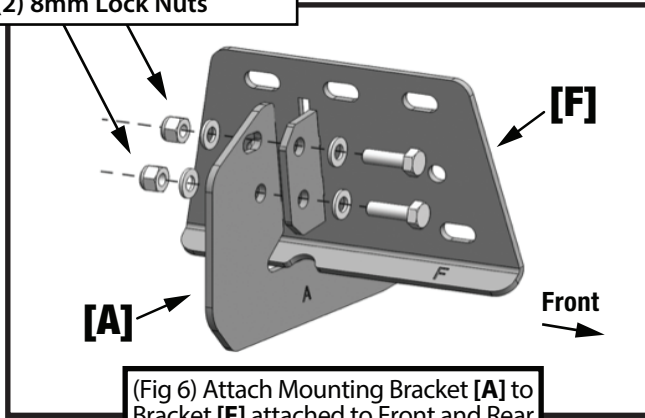

(Fig 6) Attach Mounting Bracket [A] to Bracket [F] attached to Front and Rear Mounting Studs

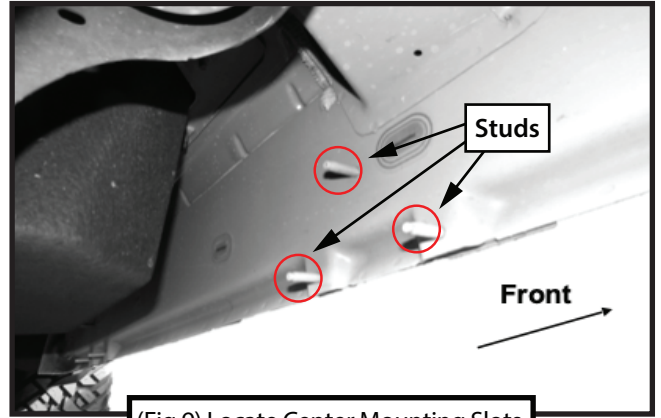

(Fig 9) Locate Center Mounting Slots

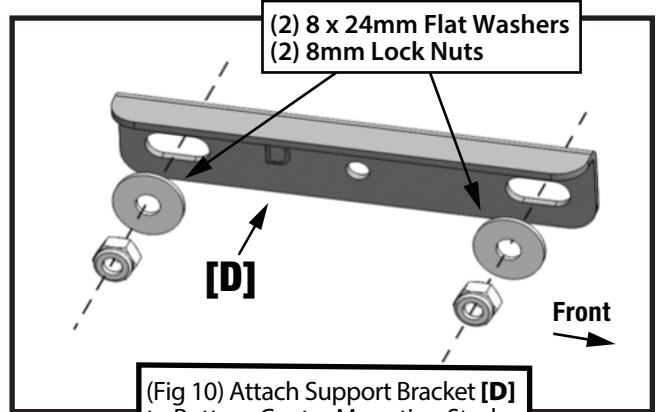

(Fig 10) Attach Support Bracket [D] to Bottom Center Mounting Studs

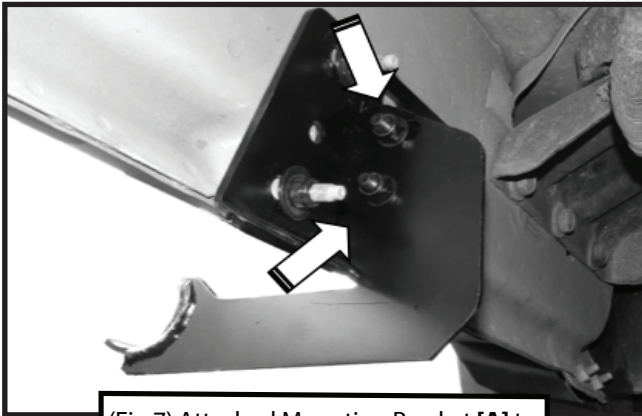

(Fig 7) Attached Mounting Bracket [A] to Bracket [F] at Front Mounting Studs

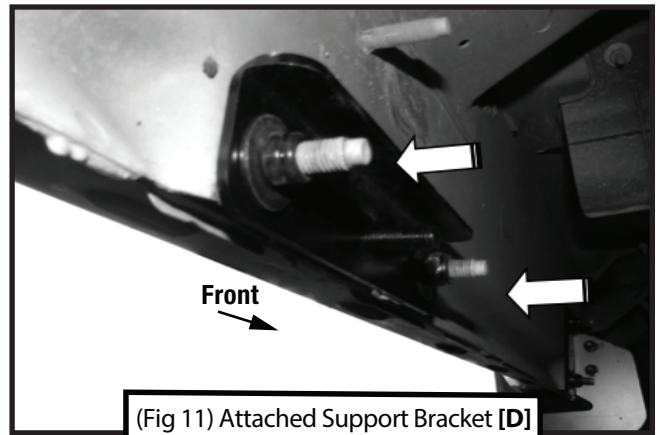

(Fig 11) Attached Support Bracket [D] to Bottom Center Mounting Studs

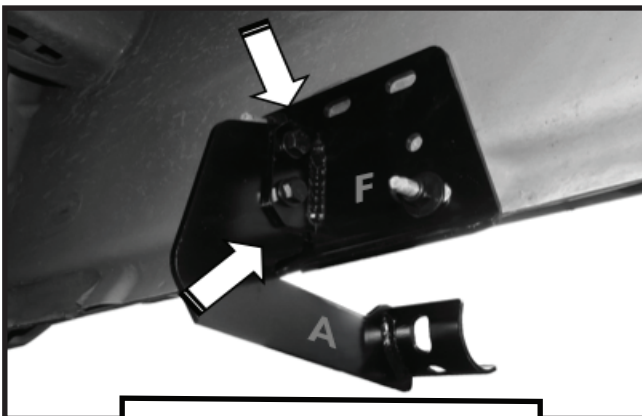

(Fig 8) Attached Mounting Bracket [A] to Bracket [F] at Rear Mounting Studs

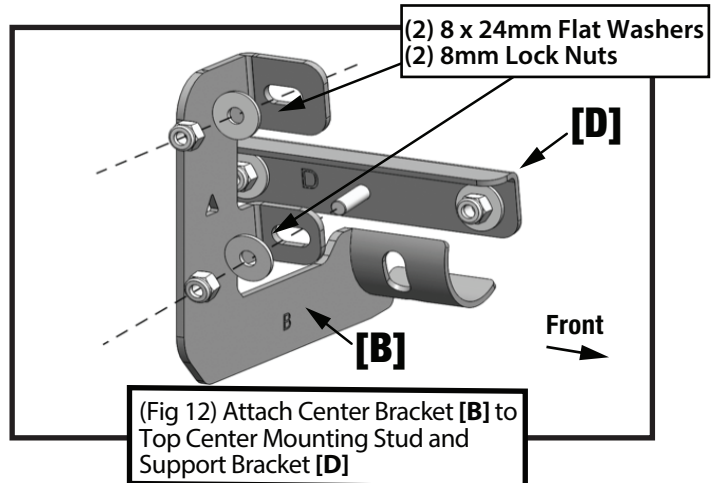

(Fig 12) Attach Center Bracket [B] to Top Center Mounting Stud and Support Bracket [D]

Driver-side Center Mounting Area

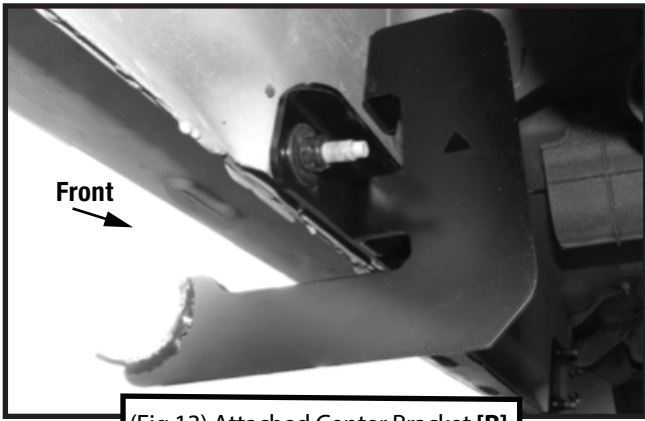

(Fig 13) Attached Center Bracket [B] with Support Bracket [D]

STEP 4 COMPLETION

Ensure Tyger Access Drop Step is level and straightened, then tighten all fasteners. Installation is complete. Perform periodic inspections to the installation to make sure that all hardware is secure and tight.

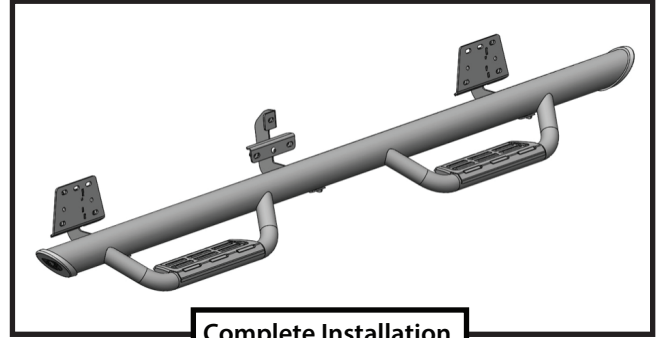

Complete Installation

STEP 2 MOUNTING RUNNING BOARD

Follow (Fig 14) to install the TYGER Access Drop Step on the Driver/Left. Ensure all hardware is hand tightened at this point.

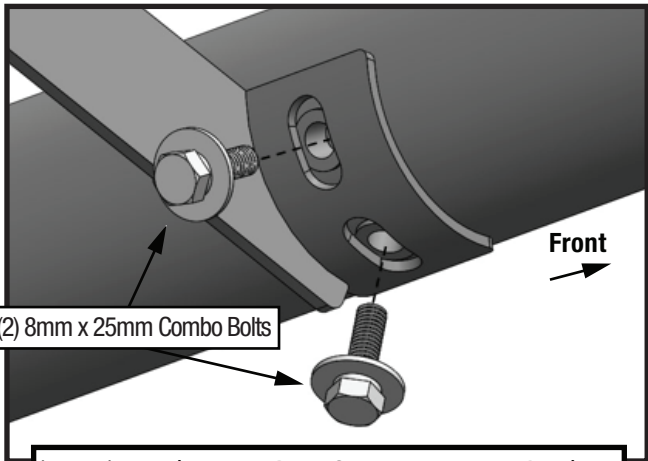

(Fig 14) Attach Access Drop Step to Mounting Brackets

STEP 3 PASSENGER SIDE

Repeat **STEPS 1-2** for passenger side installation.

