



TYGER ACCESS

TG-AS2T24003

Scan to Download the Latest Digital Version



BEFORE INSTALLATION

READ INSTRUCTIONS CAREFULLY BEFORE STARTING INSTALLATION. REMOVE CONTENTS FROM BOX AND VERIFY ALL PARTS ARE PRESENT. FAILURE TO IDENTIFY DAMAGE BEFORE INSTALLATION COULD LEAD TO A REJECTION OF ANY CLAIM. IF MISSING PARTS OR ANY DAMAGE FOUND, PLEASE TAKE A PICTURE FOR THE CLAIM PURPOSE. TO FILE YOUR CLAIM, PLEASE VISIT: WWW.TYGERAUTO.COM/CONTACT

TORQUE VALUES

Fastener Size	Class 8.8 Torque (ft-lbs)	Class 10.9 Torque (ft-lbs)
6mm	6-7	6-7
8mm	15-16	22-23
10mm	31-32	44-45
12mm	54-55	78-79
14mm	87-88	125-126

- x1** Driver/Left Tyger Access
- x1** Passenger/Right Tyger Access
- x1** Driver/Left Front Mounting Bracket [A]
- x2** Driver/Left Center & Rear Mounting Brackets [B]
- x1** Passenger/Right Front Mounting Bracket [C]
- x2** Passenger/Right Center & Rear Mounting Brackets [D]
- x12** 8-1.25 x 25mm Hex Combo Bolts
- x12** 8mm Lock Washers
- x12** 8mmx24mmx2mm Flat Washers
- x12** 8-1.25mm x 30mm Hex Bolts

Parts List

Top View

ATTENTION: Refer to **D** and **P** labelling on the side of the tubes to determine Driver and Passenger TYGER Access

P Passenger Side TYGER Access

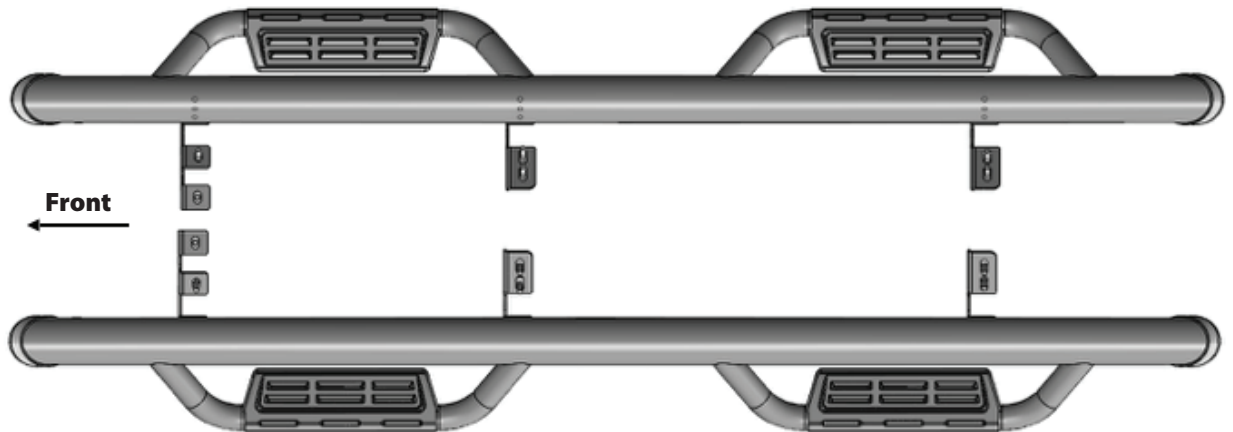
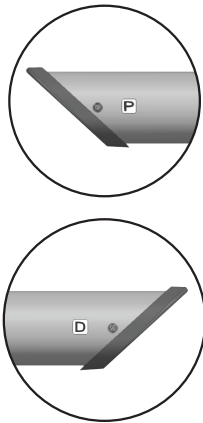

D Driver Side TYGER Access

x1 [A]
Driver/Left Front Mounting Bracket



x2 [B]
Driver/Left Center & Rear Mounting Brackets



x1 [C]
Passenger/Right Front Mounting Bracket



x2 [D]
Passenger/Right Center & Rear Mounting Brackets

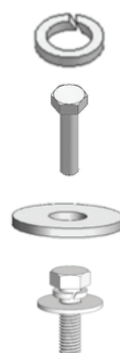

x12 8mm Lock Washers

x12 8-1.25mm x 30mm Hex Bolts

x12 8mm x 24mm x 2mm Flat Washers

x12 8-1.25mm x 25mm Hex Combo Bolts

Reference the letters printed on the brackets to determine mounting locations

Top View

D Driver Side TYGER Access

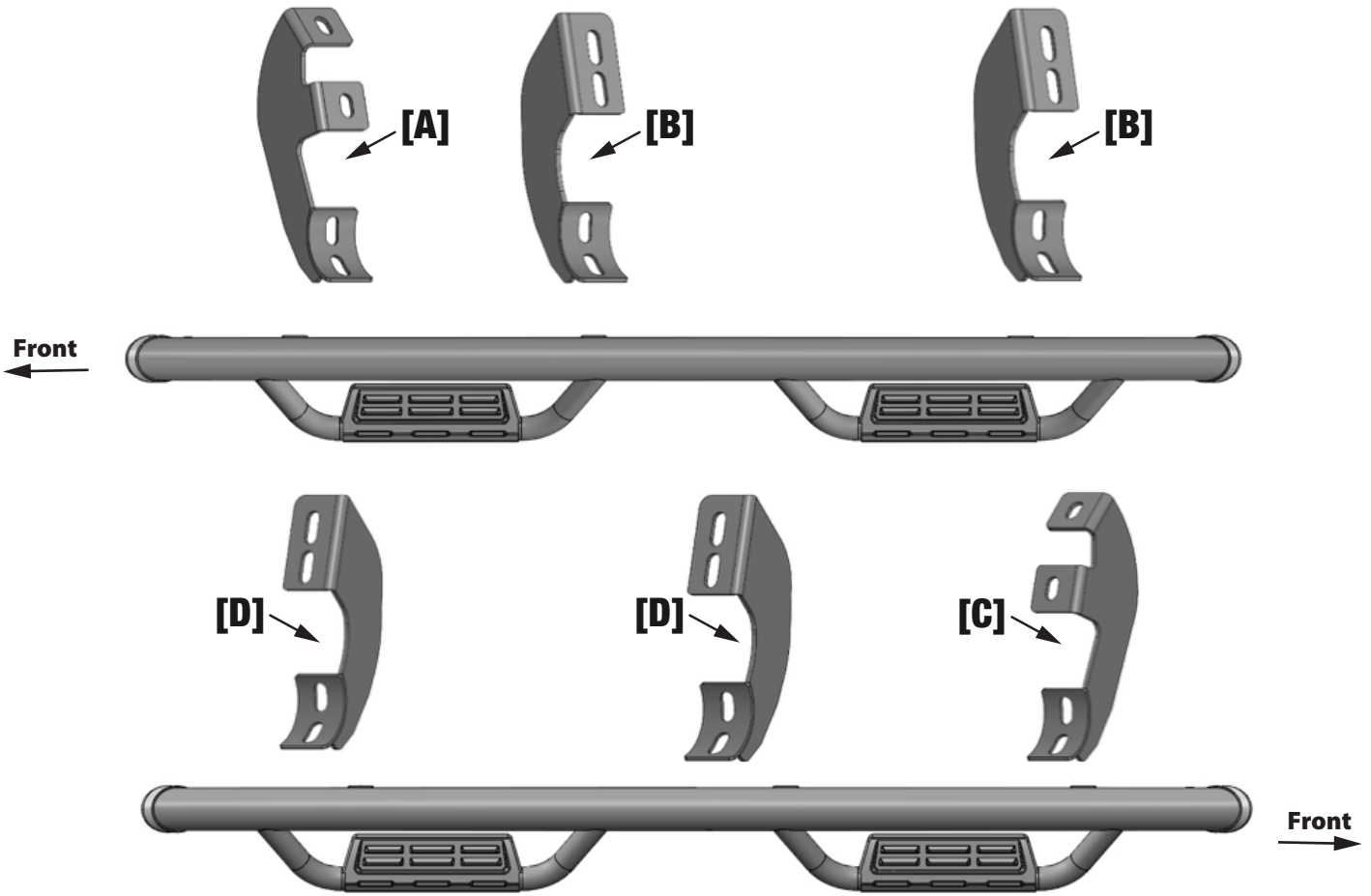

P Passenger Side TYGER Access

Bottom View

D Driver Side TYGER Access

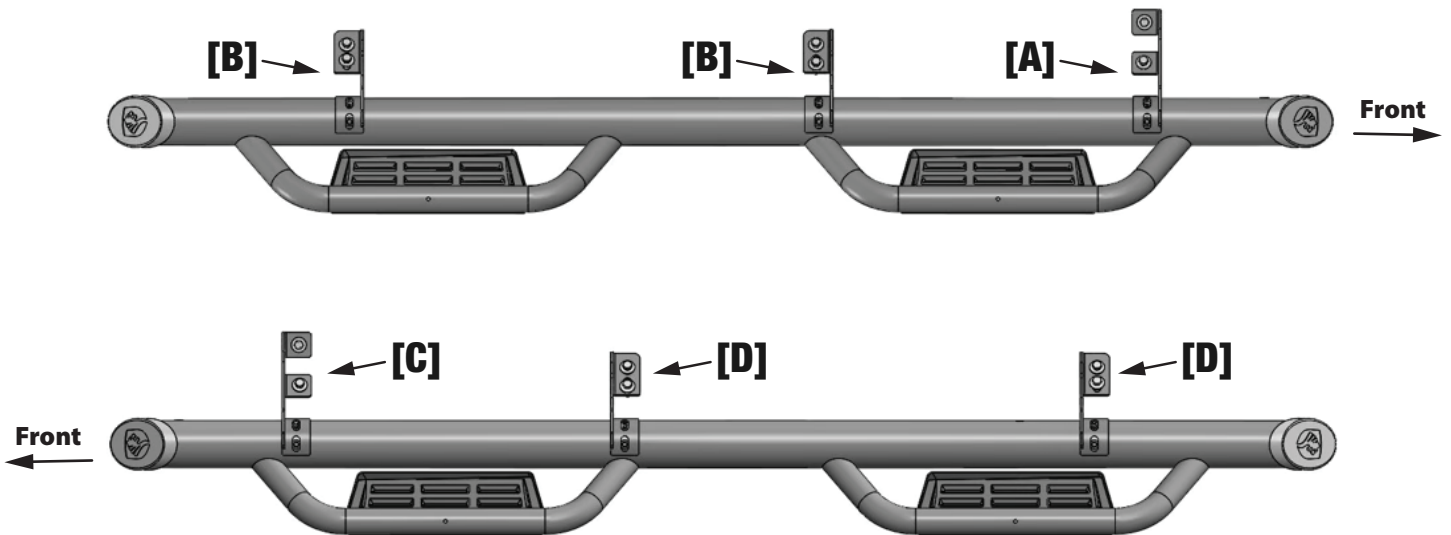

P Passenger Side TYGER Access

TOOLS REQUIRED

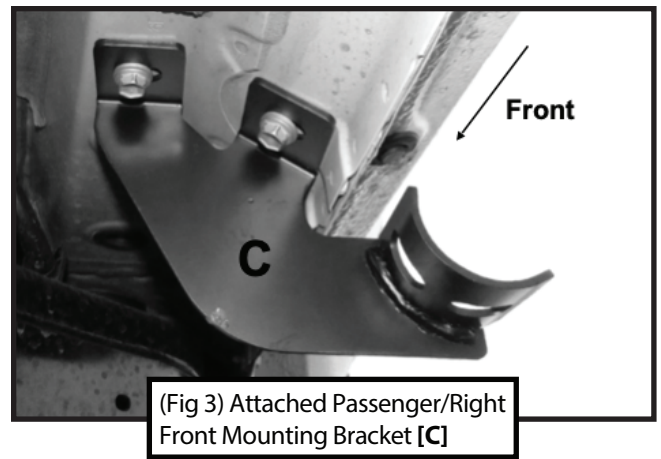
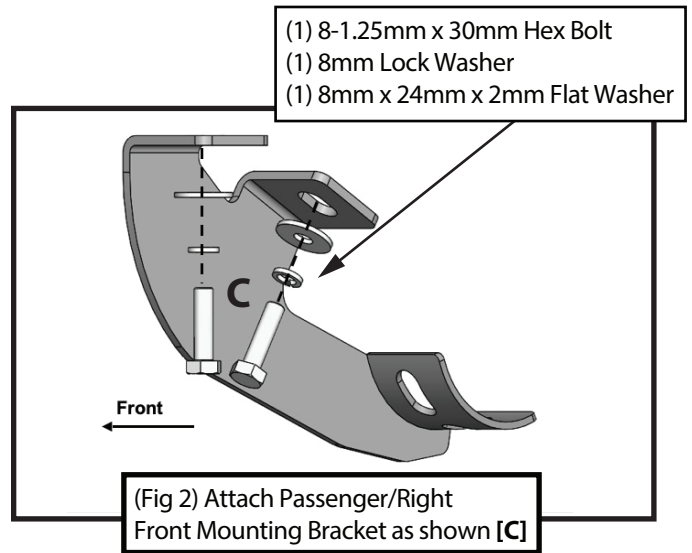
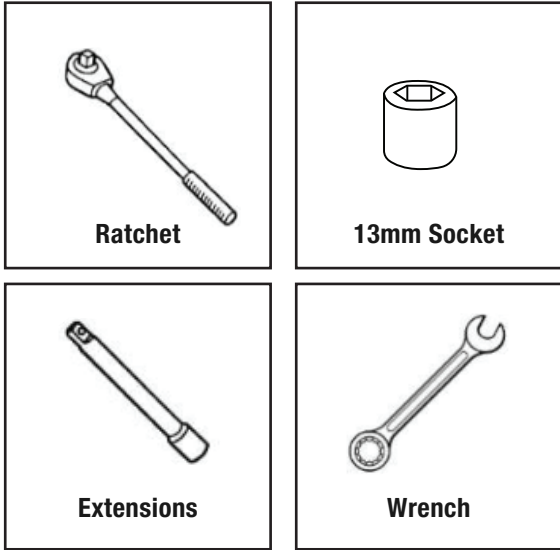

Passenger-side Center & Rear Mounting Area

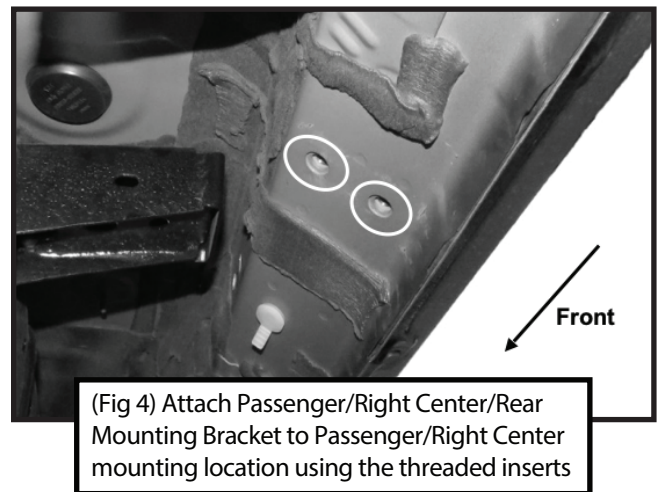

STEP 1 MOUNTING BRACKETS

Follow (Fig 1 – 6) to install the mounting brackets to the Passenger/Right Side. Hand tighten hardware only at this point.

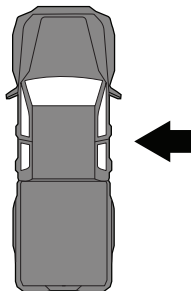

Passenger-side Front Mounting Area

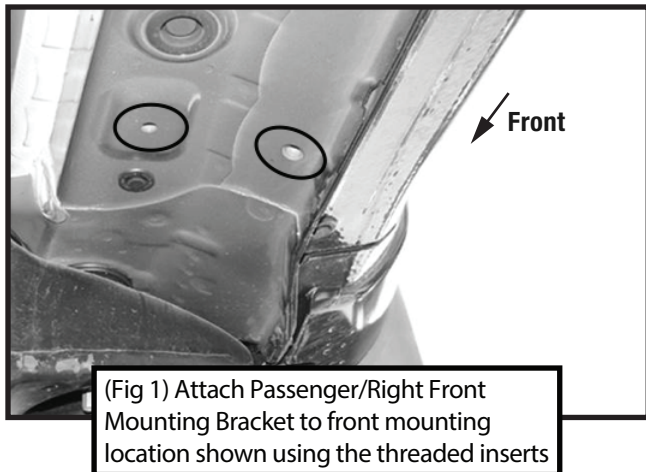

- (1) 8-1.25mm x 30mm Hex Bolt
- (1) 8mm Lock Washer
- (1) 8mm x 24mm x 2mm Flat Washer

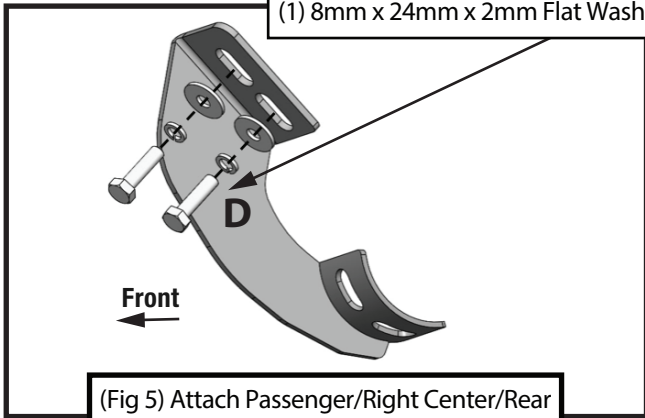

(Fig 5) Attach Passenger/Right Center/Rear Mounting Bracket as shown [D]

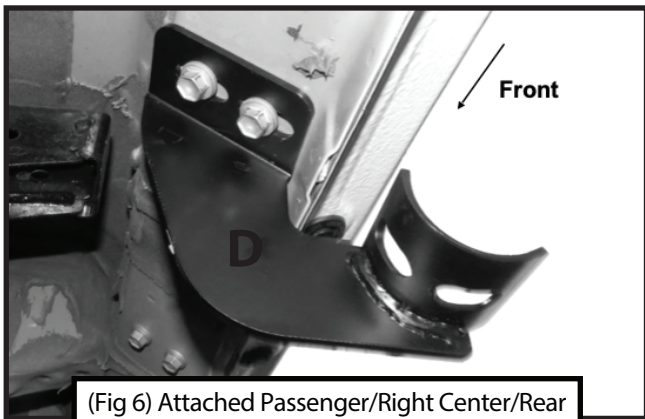

(Fig 6) Attached Passenger/Right Center/Rear Mounting Bracket [D] to Vehicle.

STEP 3 DRIVER SIDE

Repeat **STEPS 1-2** for driver side installation.
Use Front Mounting Bracket [A] instead of [C];
Use Center & Rear Mounting Brackets [B] instead of [D].

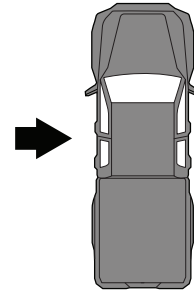

STEP 4

Ensure Tyger Access Drop Step is level and straightened, then tighten all fasteners. Installation is complete. Perform periodic inspections to the installation to make sure that all hardware is secure and tight.

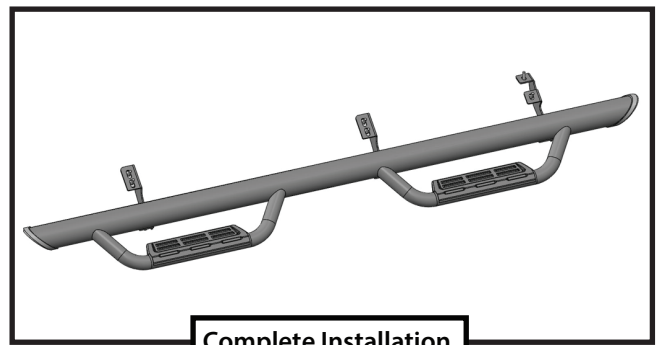

Complete Installation

STEP 2 MOUNTING RUNNING BOARD

Follow (Fig 7) to install the Tyger Access Drop Step on the Passenger/Right Mounting Brackets. Ensure all hardware is hand tightened at this point.

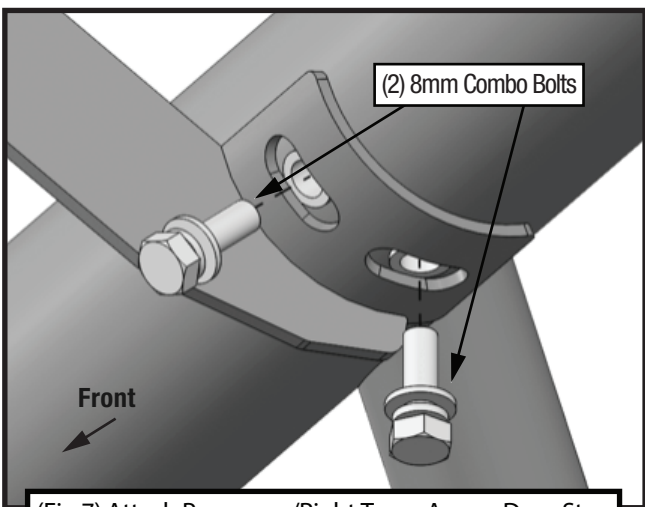

(Fig 7) Attach Passenger/Right Tyger Access Drop Step to Passenger/Right Mounting Brackets, as shown, for all mounting brackets.