



TYGER ACCESS

TG-AS2T24004

Scan to Download the Latest Digital Version



BEFORE INSTALLATION

READ INSTRUCTIONS CAREFULLY BEFORE STARTING INSTALLATION. REMOVE CONTENTS FROM BOX AND VERIFY ALL PARTS ARE PRESENT. FAILURE TO IDENTIFY DAMAGE BEFORE INSTALLATION COULD LEAD TO A REJECTION OF ANY CLAIM. IF MISSING PARTS OR ANY DAMAGE FOUND, PLEASE TAKE A PICTURE FOR THE CLAIM PURPOSE. TO FILE YOUR CLAIM, PLEASE VISIT: WWW.TYGERAUTO.COM/CONTACT

TORQUE VALUES

Fastener Size	Class 8.8 Torque (ft-lbs)	Class 10.9 Torque (ft-lbs)
6mm	6-7	6-7
8mm	15-16	22-23
10mm	31-32	44-45
12mm	54-55	78-79
14mm	87-88	125-126

- x1** Driver/Left Tyger Access
- x1** Passenger/Right Tyger Access
- x1** Driver/Left Front Mounting Bracket [A]
- x2** Driver/Left Center and Rear Mounting Brackets [B]
- x1** Passenger/Right Front Mounting Bracket [C]
- x2** Passenger/Right Center and Rear Mounting Brackets [D]
- x12** 8-1.25 x 25mm Hex Combo Bolts
- x12** 8mm Lock Washers
- x12** 8mm x 24mm x 2mm Flat Washers
- x12** 8-1.25mm x 30mm Hex Bolts

Parts List

Top View

ATTENTION: Refer to **D** and **P** labelling on the side of the tubes to determine Driver and Passenger TYGER Access

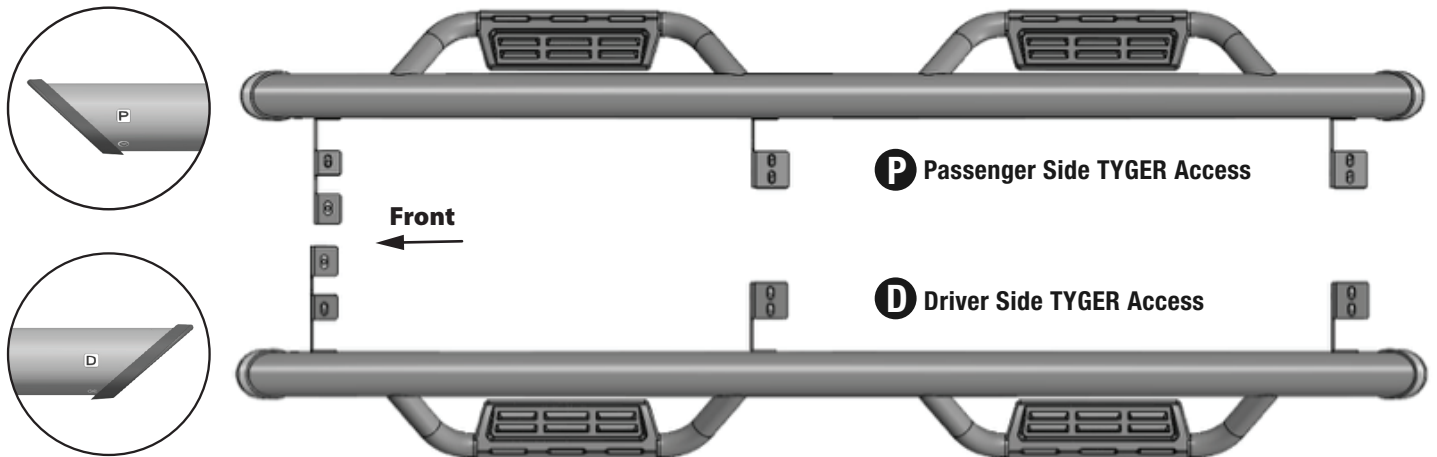

x1

[A]

Driver/Left Front Mounting Bracket



x2

[B]

Driver/Left Center & Rear Mounting Brackets



x1

[C]

Passenger/Right Front Mounting Bracket



x2

[D]

Passenger/Right Center & Rear Mounting Brackets



x12 8mm x 24mm x 2mm Flat Washers



x12 8-1.25mm x 30mm Hex Bolts



x12 8mm Lock Washers



x12 8-1.25mm x 25mm Hex Combo Bolts

Reference the letters printed on the brackets to determine mounting locations

Top View

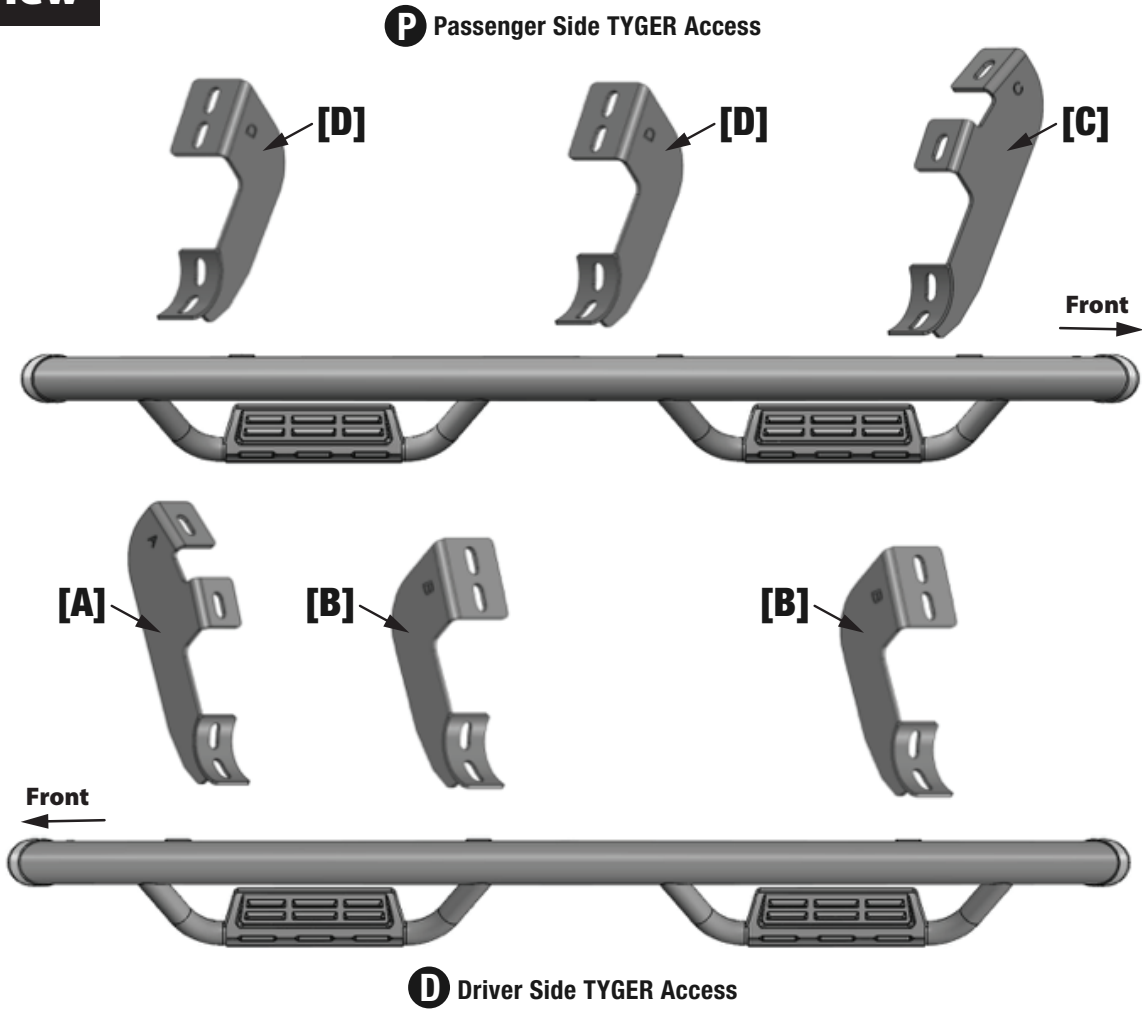

Bottom View

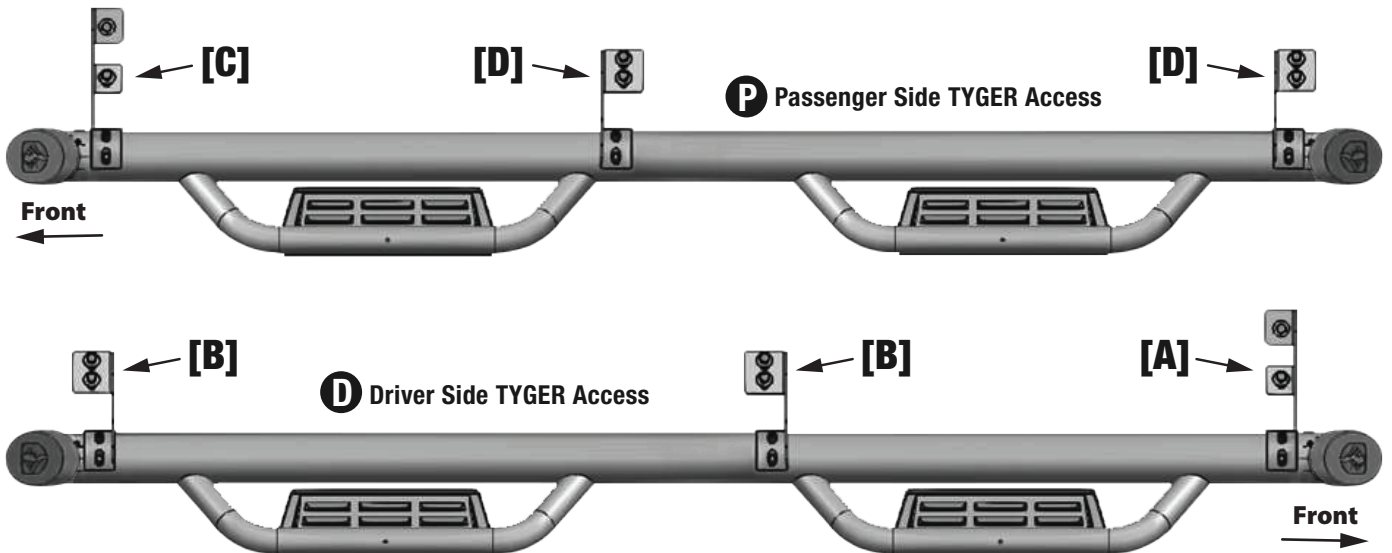

TOOLS REQUIRED

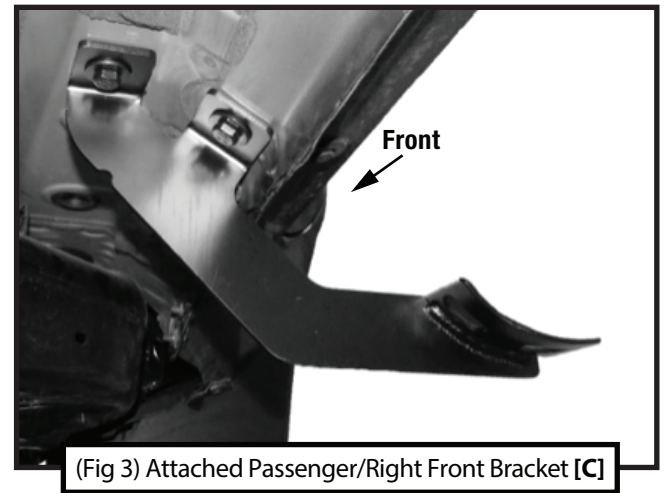
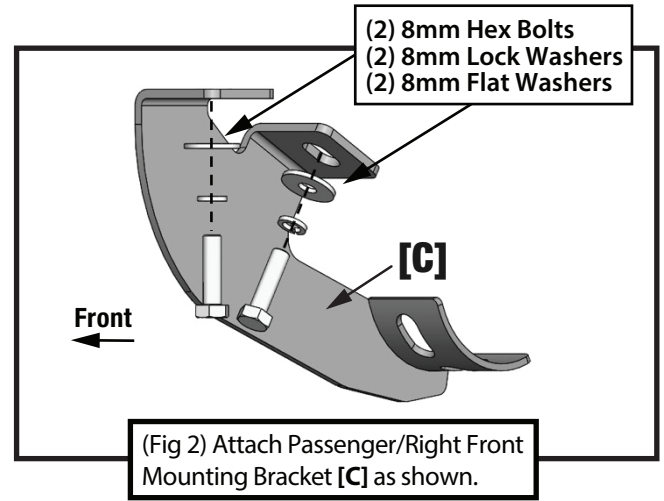
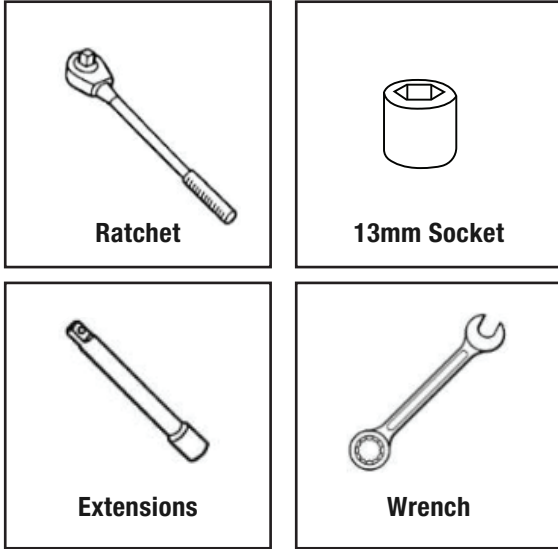

STEP 1 MOUNTING BRACKETS

Follow (Fig 1 – 8) to attach the brackets to the Passenger/Right Side. Ensure all hardware is hand tightened at this point.

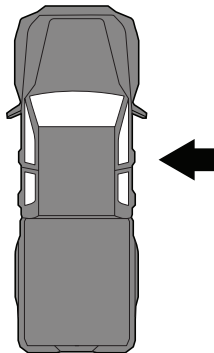

Passenger-side Front Mounting Area

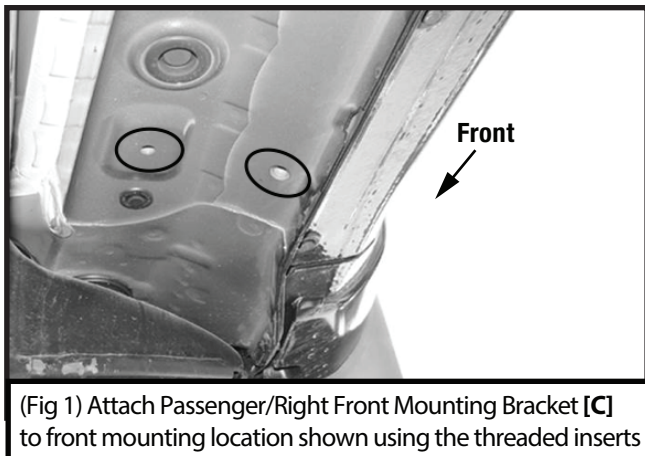

Passenger-side Center Mounting Area

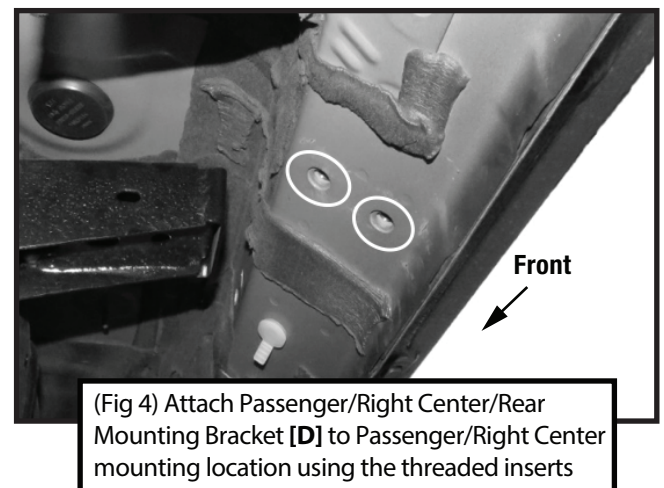

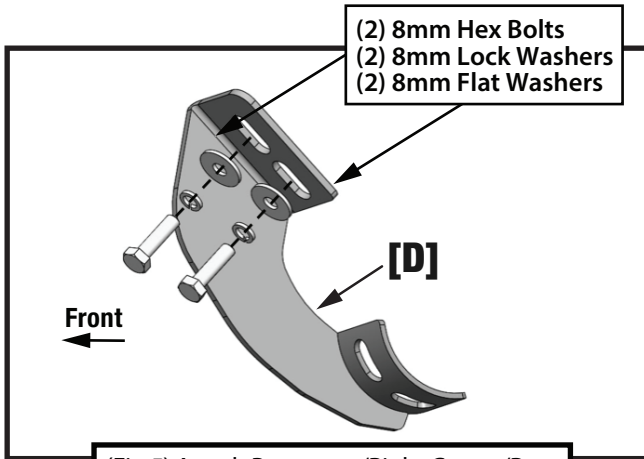

(Fig 5) Attach Passenger/Right Center/Rear Mounting Bracket [D] as shown

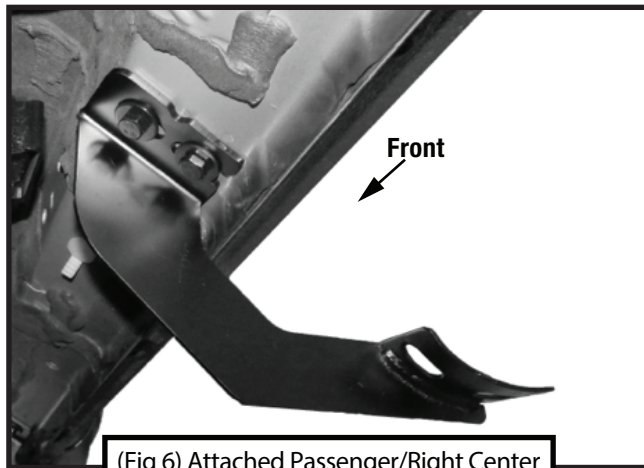

(Fig 6) Attached Passenger/Right Center Mounting Bracket [D] to Vehicle



Passenger-side Rear Mounting Area

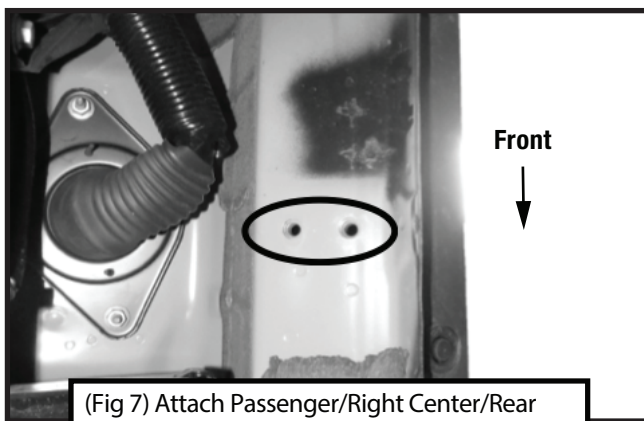

(Fig 7) Attach Passenger/Right Center/Rear Mounting Bracket [D] to Passenger/Right Rear mounting location using the threaded inserts

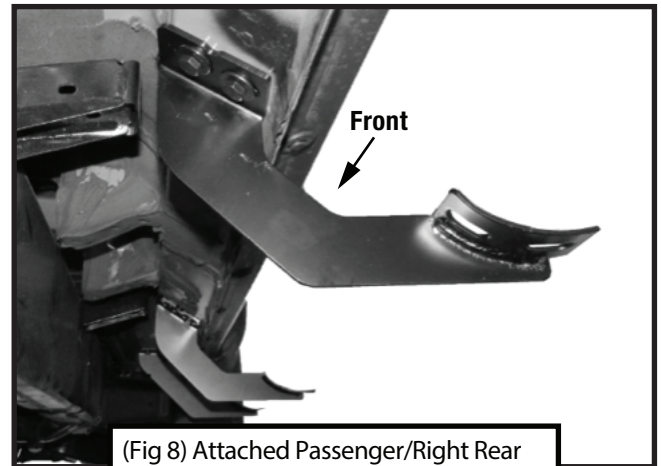

(Fig 8) Attached Passenger/Right Rear Mounting Bracket [D] to Vehicle.

STEP 2 MOUNTING RUNNING BOARD

Follow (Fig 9) to install the Tyger Access Drop Step on the Passenger/Right Mounting Brackets. Ensure all hardware is hand tightened at this point.

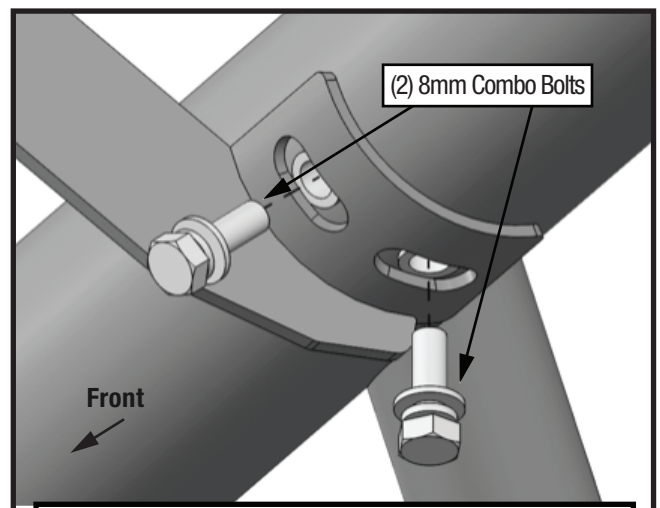

(Fig 9) Attach Passenger/Right TYGER Access Drop Step to all Passenger/Right Mounting Brackets.

STEP 3 DRIVER SIDE

Repeat **STEPS 1-2** for driver side installation.
 Use Front Mounting Bracket [A] instead of **[C]**;
 Use Center & Rear Mounting Brackets [B] instead of **[D]**.

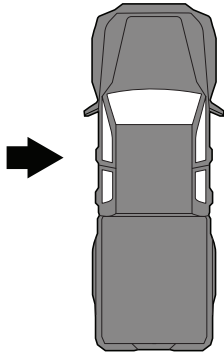

STEP 4

Ensure Tyger Access Drop Step is level and straightened, then tighten all fasteners. Installation is complete. Perform periodic inspections to the installation to make sure that all hardware is secure and tight.

