



# TYGER BLADE

TG-BL3D7038

Scan to Download the Latest Digital Version



## BEFORE INSTALLATION

READ INSTRUCTIONS CAREFULLY BEFORE STARTING INSTALLATION. REMOVE CONTENTS FROM BOX AND VERIFY ALL PARTS ARE PRESENT. FAILURE TO IDENTIFY DAMAGE BEFORE INSTALLATION COULD LEAD TO A REJECTION OF ANY CLAIM. IF MISSING PARTS OR ANY DAMAGE FOUND, PLEASE TAKE A PICTURE FOR THE CLAIM PURPOSE. TO FILE YOUR CLAIM, PLEASE VISIT:

[WWW.TYGERAUTO.COM/CONTACT](http://WWW.TYGERAUTO.COM/CONTACT)

## TORQUE VALUES

Fastener Size	Class 8.8 Torque (ft-lbs)	Class 10.9 Torque (ft-lbs)
6mm	6-7	6-7
8mm	15-16	22-23
10mm	31-32	44-45
12mm	54-55	78-79
14mm	87-88	125-126

- x2** TYGER Blade Running Boards (78in)
- x3** Mounting Brackets (A)
- x3** Mounting Brackets (B)
- x3** Support Brackets (E)
- x3** Support Brackets (F)
- x6** 8mm Bolt Plates
- x6** 8mm Plastic Retainers
- x6** 8mm Double Bolt Plates
- x12** 8mm-1.25mm x 30mm Hex Bolts
- x30** 8mm x 24mm x 2mm Flat Washers
- x6** 8mm Lock Washers
- x6** 8mm Hex Nuts
- x18** 8mm Nylon Lock Nuts
- x12** 6mm x 25mm Hex Bolts
- x24** 6mm x 22mm x 2mm Flat Washers
- x12** 6mm Nylon Lock Nuts

## Parts List

### Driver/Left Mounting Brackets

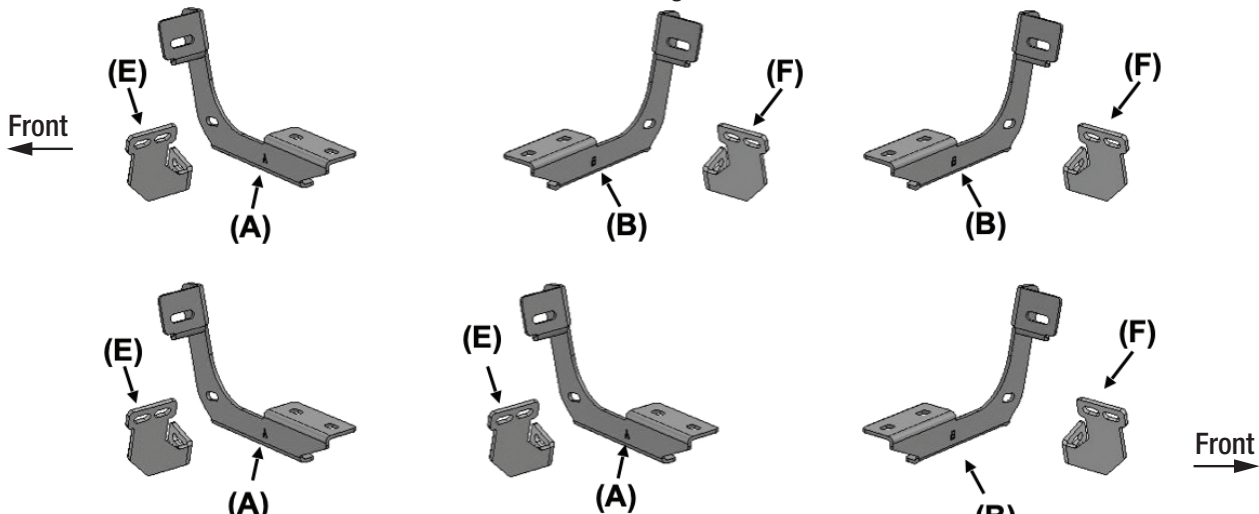

### Passenger/Right Mounting Brackets

### Bottom View Assembled Running Boards

#### Driver/Left Running Board Assembly (Bottom View)

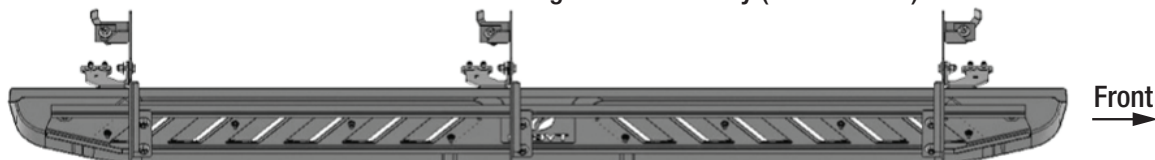

#### Passenger/Right Running Board Assembly (Bottom View)

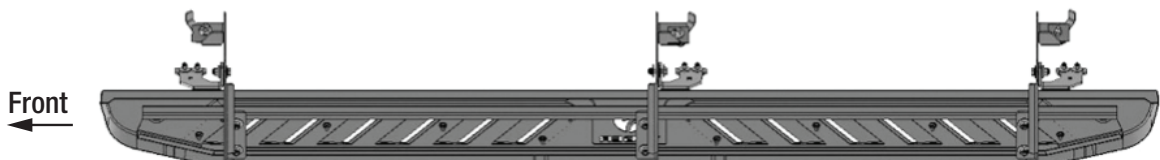

**PROCEDURE:**

REMOVE CONTENTS FROM BOX. VERIFY ALL PARTS ARE PRESENT. READ INSTRUCTIONS CAREFULLY BEFORE STARTING INSTALLATION. DRILLING MAY BE REQUIRED.

## STEP 1

Starting at the driver/left front of the vehicle, remove the sealing tape covering the factory holes in the side of the inner panel (Fig 1).

### Driver/left side Installation Pictured

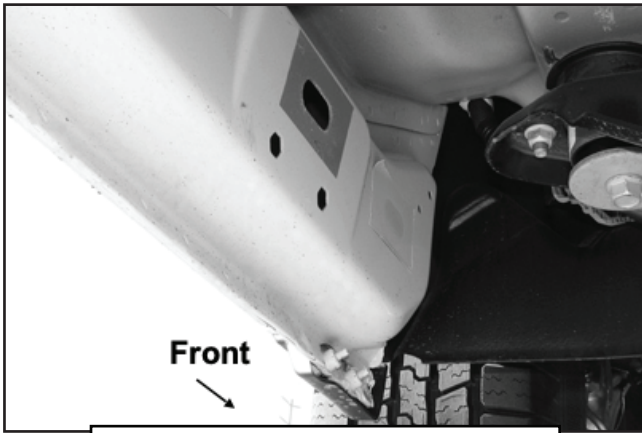

(Fig 1) 2009-mid 2015 Driver/Left front mounting location (No factory holes in pinch weld 2009-2011 models)

## STEP 2

Determine the correct procedure to attach the driver/left side front Bracket for your model/year:

### Models without factory threaded inserts in body panel:

- a. Select (1) 8mm Bolt Plate and (1) 8mm Plastic Retainer, (Fig 2). Grab the handle on the Bolt Plate and insert the Bolt Plate into the oval hole (Fig 3). Feed the threaded bolt on the Bolt Plate through the rear hex shaped factory hole.

### Driver/left side Installation Pictured

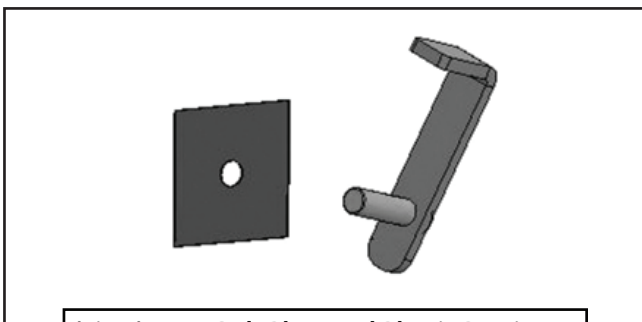

(Fig 2) 8mm Bolt Plate and Plastic Retainer. **NOTE:** Bolt Plate is not required on models with threaded mounting holes

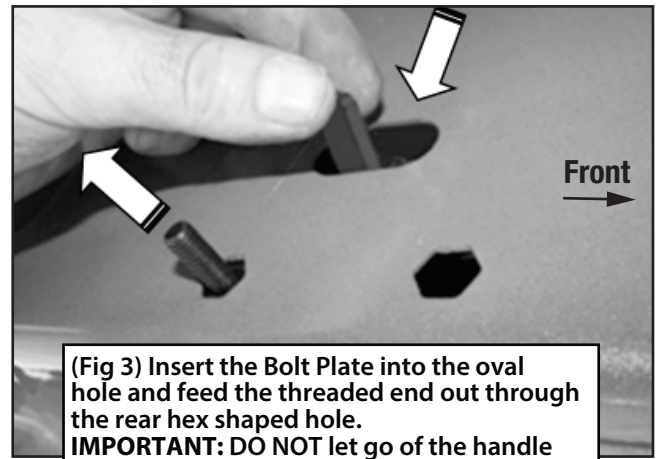

(Fig 3) Insert the Bolt Plate into the oval hole and feed the threaded end out through the rear hex shaped hole. **IMPORTANT:** DO NOT let go of the handle until after Plastic Retainer has been threaded onto bolt (Fig 4)

- b. Thread (1) 8mm Plastic Retainer onto the threaded end and down tight against the body panel (Fig 4). **NOTE:** The Plastic Retainer is designed to keep the Bolt Plate from falling into the body panel and to aid in Bracket installation.

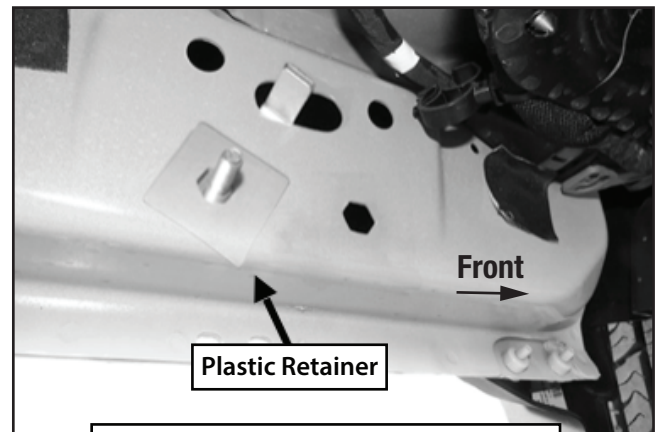

(Fig 4) Thread Plastic Retainer onto Bolt Plate to hold Bolt Plate in position.

- c. Select (1) Mounting Bracket (A) (Fig 5). Attach the Bracket to the Bolt Plate with (1) 8mm Flat Washer, (1) 8mm Lock Washer and (1) 8mm Hex Nut to the front mounting location. DO NOT tighten at this time. **NOTE:** Mounting Bracket (A) is used for driver-side front location and passenger-side center/rear locations.

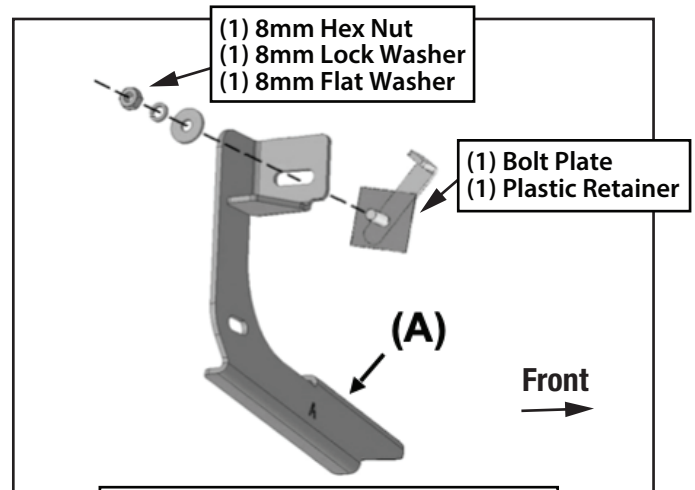

(Fig 5) Attach Mounting Bracket (A) to Bolt Plate for front mounting location

**Models with factory threaded mounting holes:**

a. Attach (1) Mounting Bracket (A) to the rear threaded mounting hole with (1) 8mm x 30mm Hex Bolt, (1) 8mm Lock Washer and (1) 8mm Flat Washer (Figs 6 & 7). Leave hardware loose. **NOTE:** Mounting Bracket (A) is used for driver-side front location and passenger-side center/rear locations.

**IMPORTANT:** Rust or dirt may build up overtime and clog up the holes preventing the bolts to be installed. In this case, use a 8-1.25mm Tap (not included) to clear and cut new threads to allow the bolts to be mounted.

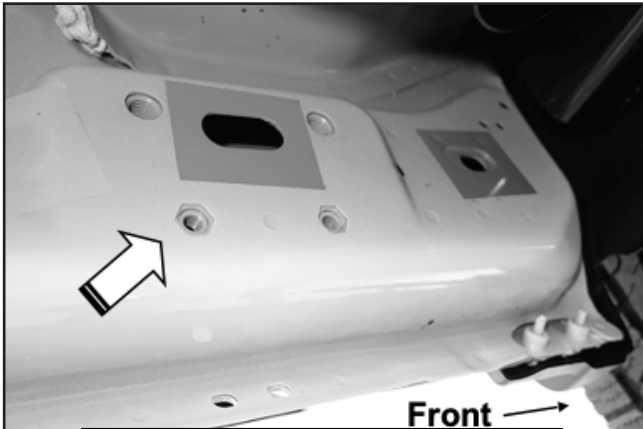

(Fig 6) Example of driver/left front mid 2015-on mounting location with factory installed threaded mounting holes

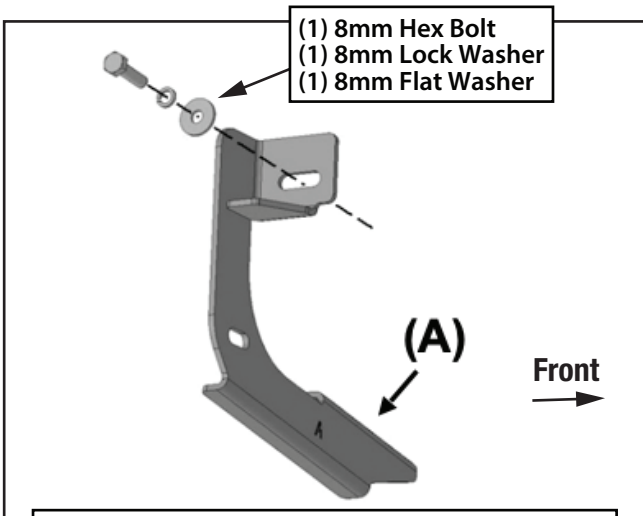

(Fig 7) Attach Mounting Bracket (A) directly to threaded holes in front mounting location (Fig 6). Bolt Plate not required

**STEP 3**

Select (1) Support Bracket (E) (Fig 8). Attach the Support Bracket to the front facing side of the Mounting Bracket with (1) 8mm x 30mm Hex Bolt, (2) 8mm Flat Washers and (1) 8mm Nylon Lock Nut. **NOTE:** Support Bracket (E) is used for driver-side front location and passenger-side center/rear locations.

Driver/left side Installation Pictured

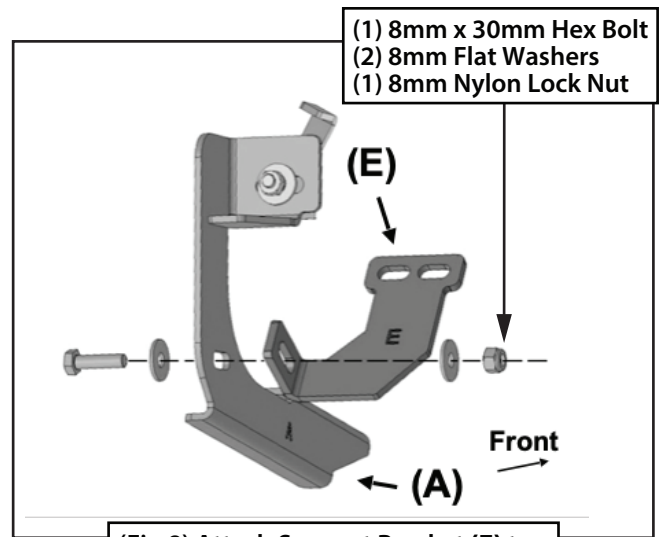

(Fig 8) Attach Support Bracket (E) to front facing side of Mounting Bracket

**STEP 4**

Line up the slots in the top of the Support Bracket with the (2) factory holes in the pinch weld. Attach the Support Bracket to the back of the pinch weld with (2) 6mm x 25mm Hex Bolts, (4) 6mm Flat Washers and (2) 6mm Nylon Lock Nuts (Fig 9). **DO NOT** fully tighten hardware at this time. **IMPORTANT:** 2009-11 models are not equipped with factory holes and will require drilling through the pinch weld to attach the Support Bracket. **DO NOT** drill through pinch weld at this time, (see **STEP 10**).

**IMPORTANT:** 2009-2011 models without holes in pinch weld will require drilling 1/4" holes through pinch weld to attach support brackets. Do complete installation of Running Boards first, level Running Boards before drilling holes for Support Brackets.

Driver/left side Installation Pictured

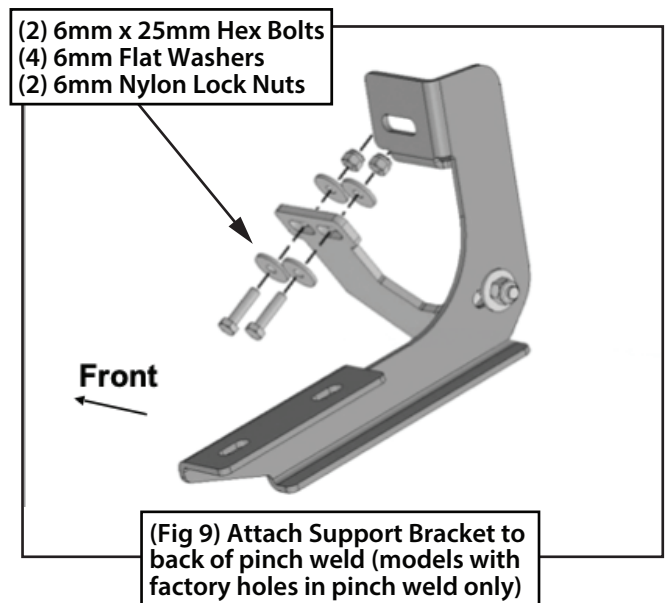

(Fig 9) Attach Support Bracket to back of pinch weld (models with factory holes in pinch weld only)

**STEP 5**

Move along the side of the body panel to the next mounting location in the center of the cab (Fig 10). Select (1) Mounting Bracket (B) (Fig 11). Repeat the appropriate **STEP 2** to install the Bracket (Figs 11 & 12). **NOTE:** Mounting Bracket (B) is used for driver-side center/rear locations and passenger-side front locations, and is attached to the forward hex hole or threaded hole as previously described (Fig 10).

**Driver/left side Installation Pictured**

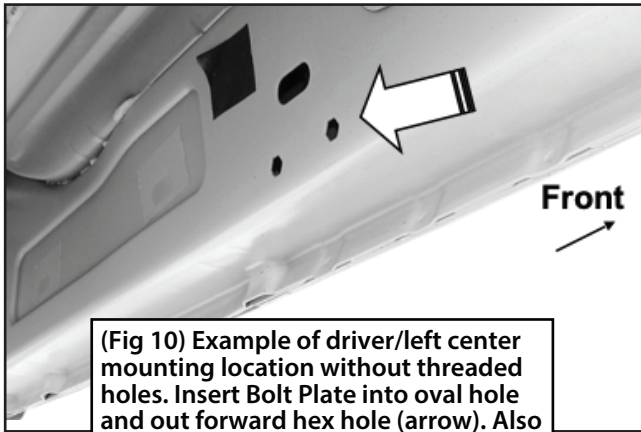

(Fig 10) Example of driver/left center mounting location without threaded holes. Insert Bolt Plate into oval hole and out forward hex hole (arrow). Also see Figs 3 & 4

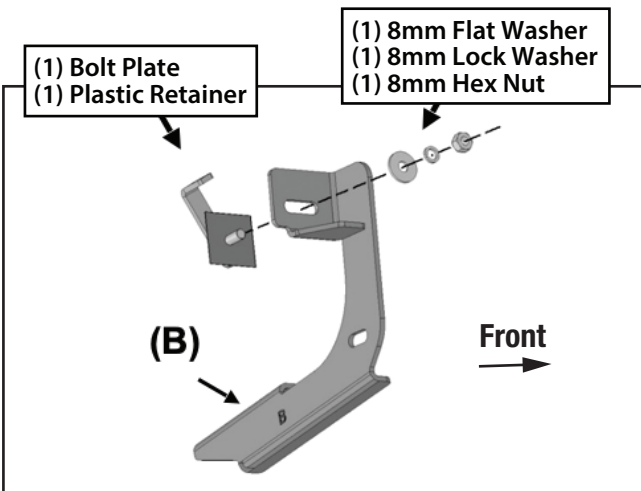

(Fig 11) Attach (1) Mounting Bracket (B) to Bolt Plate

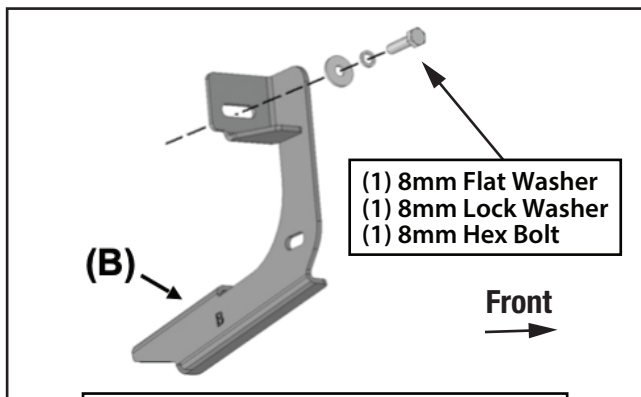

(Fig 12) Attach (1) Mounting Bracket (B) directly to threaded holes in mounting location (Fig 6). Bolt Plate not required

**STEP 6**

Select (1) Support Bracket (F) (Fig 13). Repeat **STEPS 3 & 4** to attach the Support Bracket to the rear facing side of the Mounting Bracket and holes in pinch weld if equipped (Fig 14).

**Driver/left side Installation Pictured**

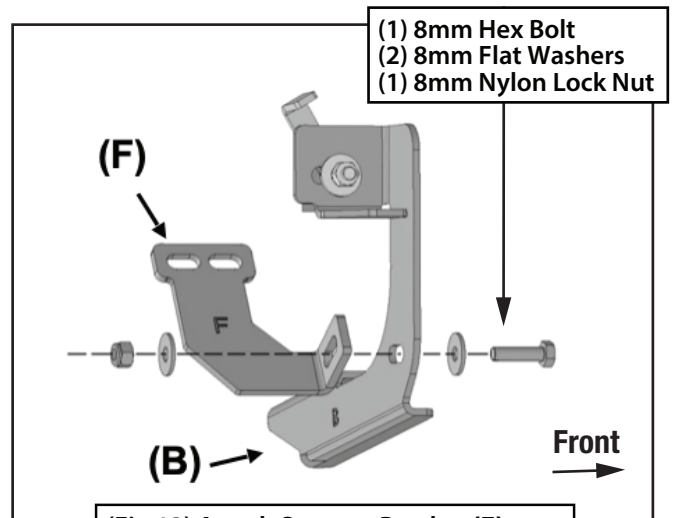

(Fig 13) Attach Support Bracket (F) to rear facing side of Mounting Bracket (B)

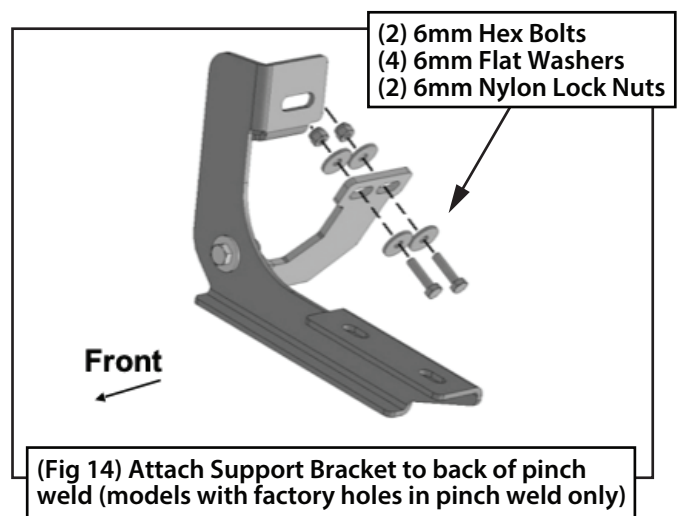

(Fig 14) Attach Support Bracket to back of pinch weld (models with factory holes in pinch weld only)



**STEP 7**

Move to the next mounting location at the rear of the cab (Fig 15). Repeat **STEPS 5 & 6** to install Mounting Bracket (**B**) and Support Bracket (**F**).

**Driver/left side Installation Pictured**

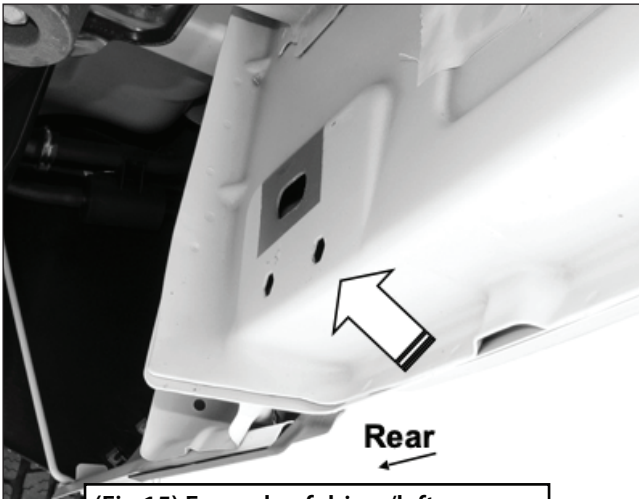

(Fig 15) Example of driver/left rear mounting location without threaded holes. Insert Bolt Plate into oval hole and out forward hex hole (arrow). Also see Figs 3 & 4

**STEP 8**

Select (1) Running Board. Place the Running Board on top of the Brackets. Locate the channel in the bottom of the Running Board. Select (3) 8mm Double Bolt Plates. Insert the Bolt Plates into the channel in the bottom of the Running Board closest to the Brackets (Fig 16). Lift the Running Board up and guide the studs on the Bolt Plates down through the Brackets.

**Driver/left side Installation Pictured**

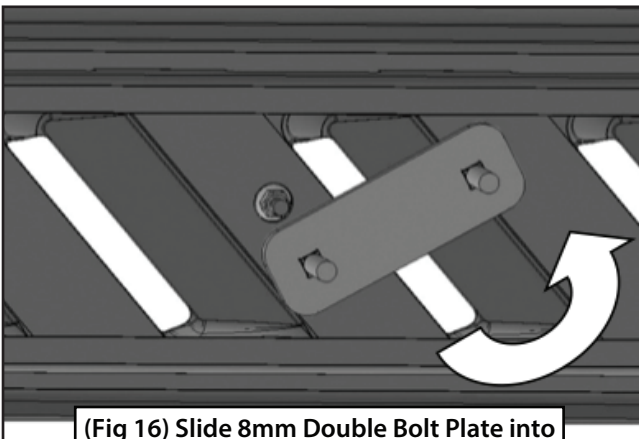

(Fig 16) Slide 8mm Double Bolt Plate into channel on bottom of Running Board

**STEP 9**

Attach the Running Board to the Brackets with (6) 8mm Flat Washers and (6) 8mm Nylon Lock Nuts (Figs 17 & 18). **DO NOT** tighten hardware at this time.

**Driver/left side Installation Pictured**

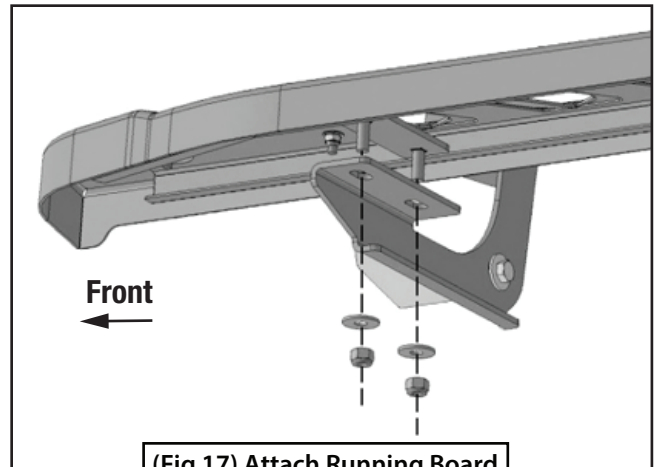

(Fig 17) Attach Running Board to driver/left Front Bracket

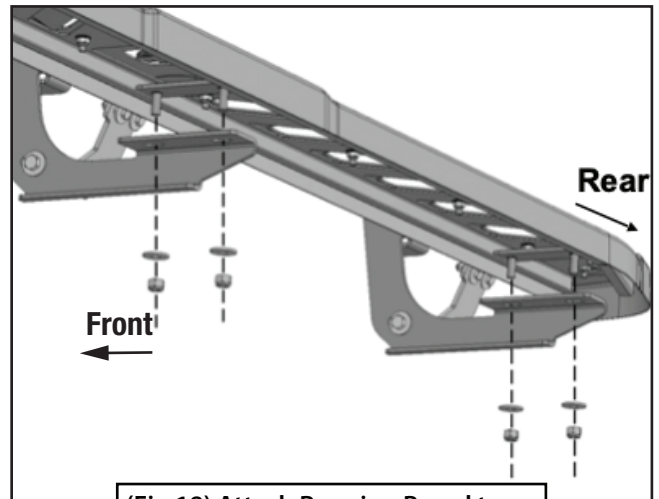

(Fig 18) Attach Running Board to driver/left Center and Rear Brackets

## STEP 10

Properly level and adjust the Running Board and fully tighten all hardware.

### 2009-12 models requiring drilling to attach Brackets to pinch weld:

- a. Level the Running Board to the vehicle. Make sure all (3) Brackets are tight against the bottom of the body panel and tighten all mounting hardware.
- b. Mark the location of the slots in the Support Brackets onto the pinch weld. **DO NOT** mark too close to the bottom edge of the pinch weld.
- c. Temporarily remove the Running Board and the (3) Mounting Brackets. Drill (2) 1/4" holes through the pinch weld for each Bracket. **IMPORTANT:** **DO NOT** drill too close to the bottom edge of the pinch weld. Drill the holes in the center of the marked slots.
- d. Repeat **STEP 4** to attach the Brackets to the drilled holes in the pinch weld. Check for level then fully tighten all hardware.

## STEP 11

Repeat **STEPS 1-10** for passenger/right Running Board.

Note: For passenger side, use Brackets **(B)** and **(F)** for the front location and Brackets **(A)** and **(E)** for the center and rear locations.

## STEP 12

Do periodic inspections to the installation to make sure that all hardware is secure and tight.