



TYGER BLADE

TG-BL7C7158

BEFORE INSTALLATION

READ INSTRUCTIONS CAREFULLY BEFORE STARTING INSTALLATION. REMOVE CONTENTS FROM BOX AND VERIFY ALL PARTS ARE PRESENT. FAILURE TO IDENTIFY DAMAGE BEFORE INSTALLATION COULD LEAD TO A REJECTION OF ANY CLAIM. IF MISSING PARTS OR ANY DAMAGE FOUND, PLEASE TAKE A PICTURE FOR THE CLAIM PURPOSE. TO FILE YOUR CLAIM, PLEASE VISIT: WWW.TYGERAUTO.COM/CONTACT

TORQUE VALUES

Fastener Size	Class 8.8 Torque (ft-lbs)	Class 10.9 Torque (ft-lbs)
6mm	6-7	6-7
8mm	15-16	22-23
10mm	31-32	44-45
12mm	54-55	78-79
14mm	87-88	125-126

- x2** TYGER Running Boards (88in)
- x8** 8mm Double Bolt Plates
- x32** 8mm x 24mm x 2mm Flat Washers
- x16** 8mm Nylon Lock Nuts
- x8** Mounting Brackets
- x16** 8-1.25mm x 30mm Hex Bolts
- x16** 8mm Lock Washers

Parts List

NOTE: (8) Mounting Brackets (same Brackets used for driver/left and passenger/right installation)

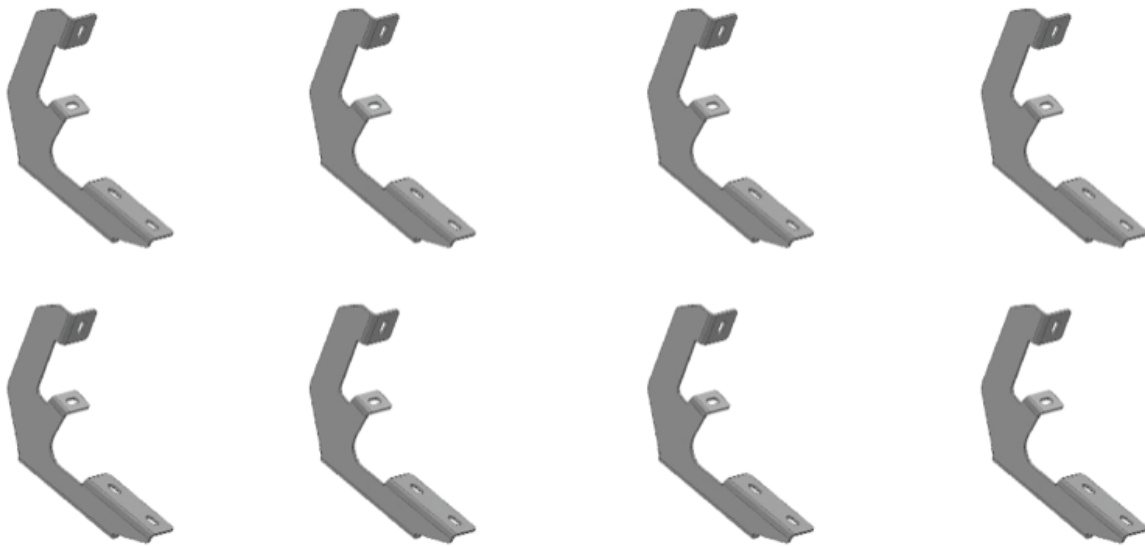

Bottom View Assembled Running Boards
Driver/Left Running Board Assembly (Bottom View)



Passenger/Right Running Board Assembly (Bottom View)

PROCEDURE:

REMOVE CONTENTS FROM BOX. VERIFY ALL PARTS ARE PRESENT. READ INSTRUCTIONS CAREFULLY BEFORE STARTING INSTALLATION. ASSISTANCE IS RECOMMENDED.

STEP 1

Start the installation under the passenger/right side of the vehicle. Locate the plugs along the bottom of the body (Fig 1). Remove the plastic plug from the front mounting location to locate the threaded hole in the bottom of the rocker panel (Fig 2). Directly above each threaded hole is a top mounting location on the side of the body panel. Hold a Bracket up in place to help determine the correct upper mounting hole to use along the body. **NOTE:** Thread an 8mm Hex Bolt into the threaded holes to clear paint as required.

Passenger/right side Installation Pictured

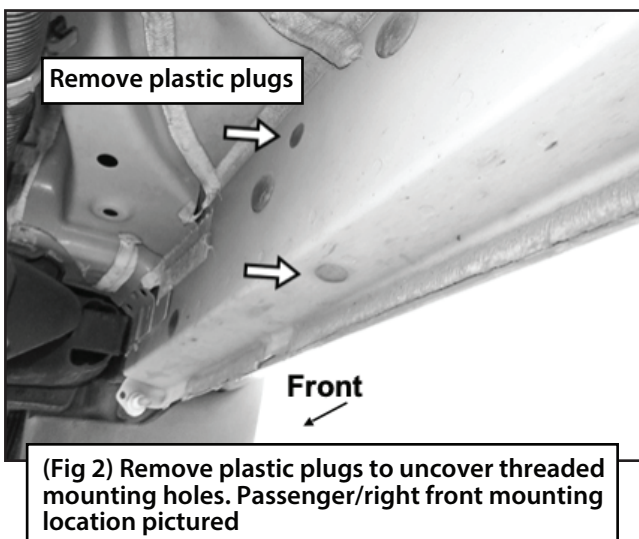
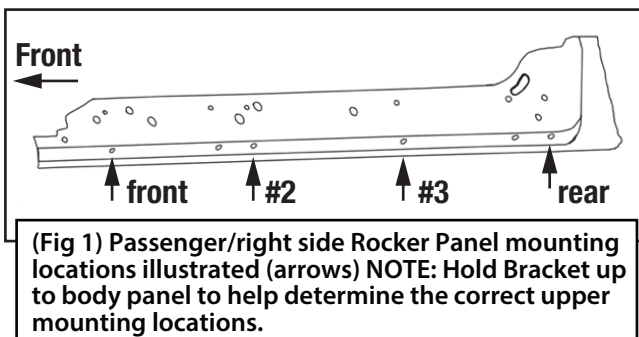

STEP 2

Select (1) Mounting Bracket. Starting at the front mounting location, attach the Mounting Bracket to the factory threaded holes with (2) 8mm Hex Bolts, (2) 8mm Lock Washers and (2) 8mm Flat Washers (Figs 3 & 4). DO NOT tighten hardware at this time.

Passenger/right side Installation Pictured

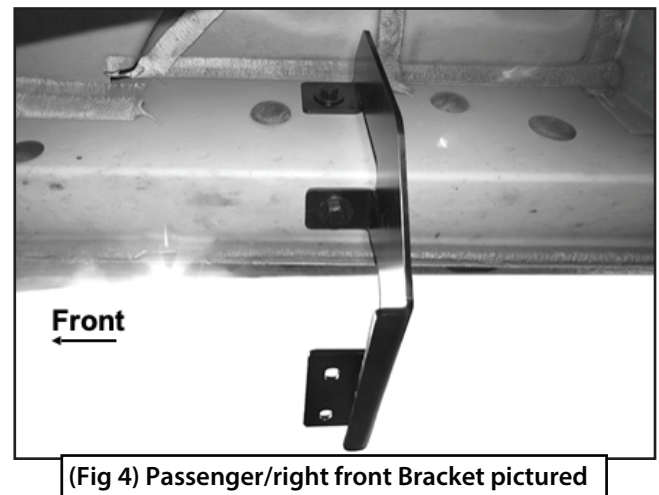
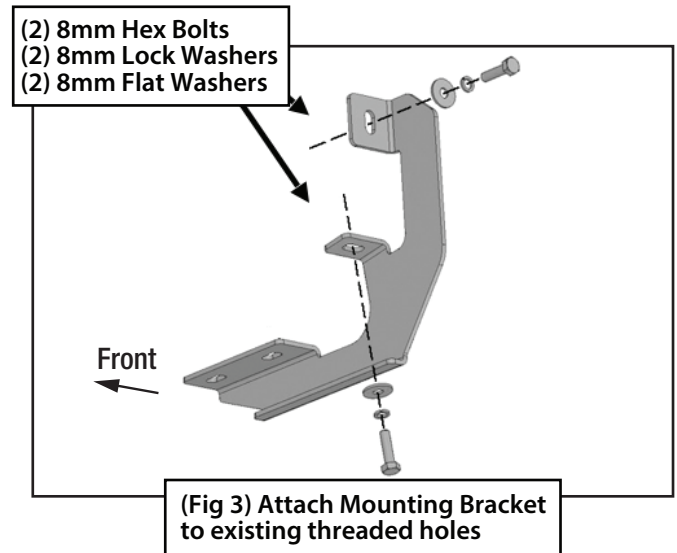

STEP 3

Move to the #2 & #3 mounting locations (Figs 5-6). Repeat **STEP 2** to attach (1) Mounting Brackets to the #2 & #3 mounting locations (Fig 7).

Passenger/right side Installation Pictured

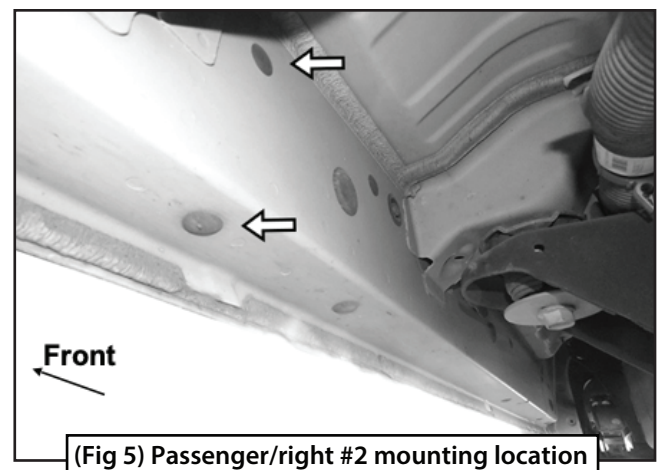

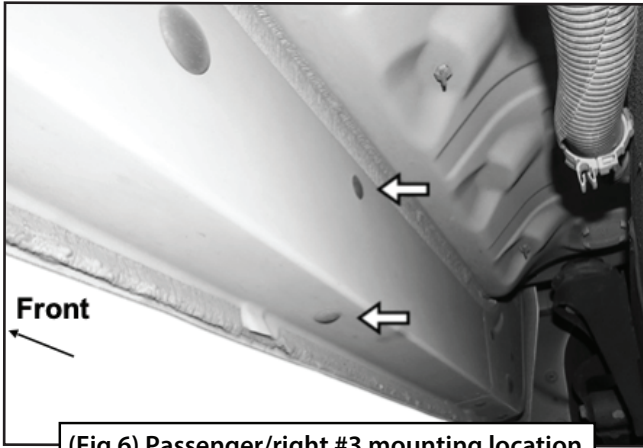

(Fig 6) Passenger/right #3 mounting location

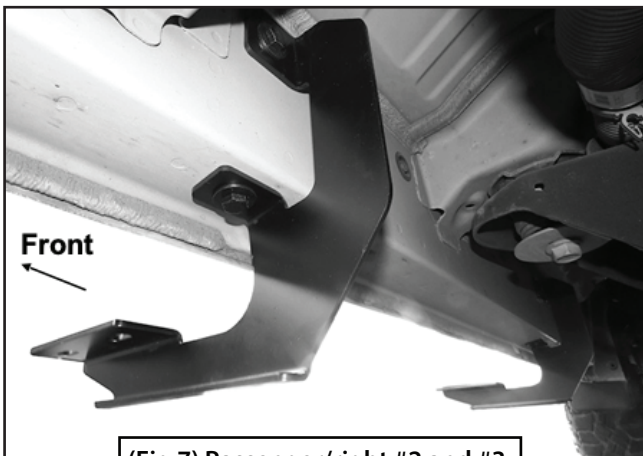

(Fig 7) Passenger/right #2 and #3 Mounting Brackets installed



(Fig 9) Passenger/right rear Bracket installed

STEP 5

Select (1) Running Board. Place the Running Board on top of the Brackets. Locate the channel in the bottom of the Running Board. Select (4) 8mm Double Bolt Plates. Insert the Bolt Plates into the channel in the bottom of the Running Board closest to the Brackets (Fig 10). Lift the Board up and guide the studs down through the Mounting Brackets.

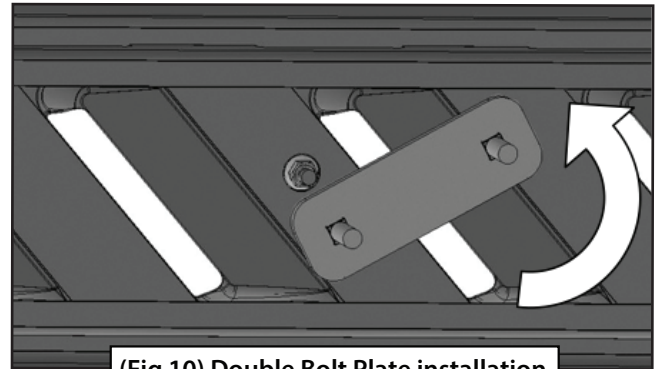

(Fig 10) Double Bolt Plate installation

STEP 4

Move to the last mounting location at the rear of the cab (Fig 8). Repeat **STEP 2** to attach (1) Mounting Bracket to the rear mounting location (Fig 9).

Passenger/right side Installation Pictured

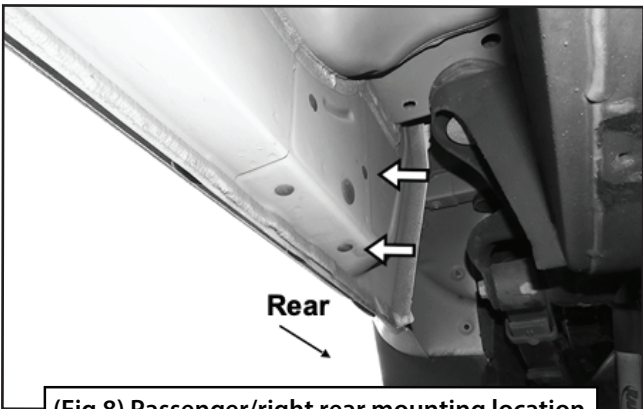

(Fig 8) Passenger/right rear mounting location

STEP 6

Attach the Running Board to the Brackets with (8) 8mm Flat Washers and (8) 8mm Nylon Lock Nuts (Figs 11-14).

Passenger/right side Installation Pictured

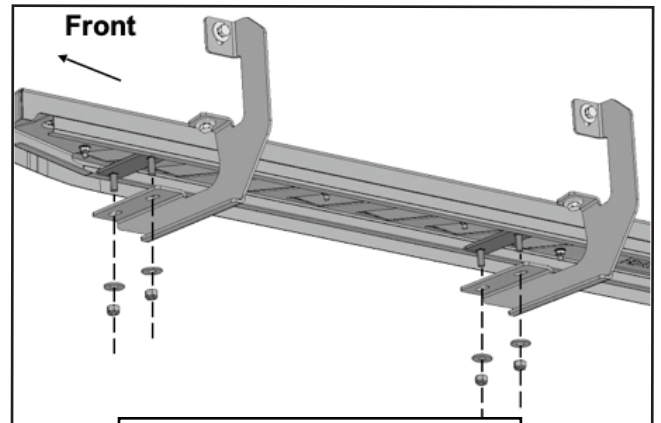

(Fig 11) Attach Running Board to front and #2 Mounting Brackets



(Fig 12) Running Board attached to #2 and #3 Mounting Brackets

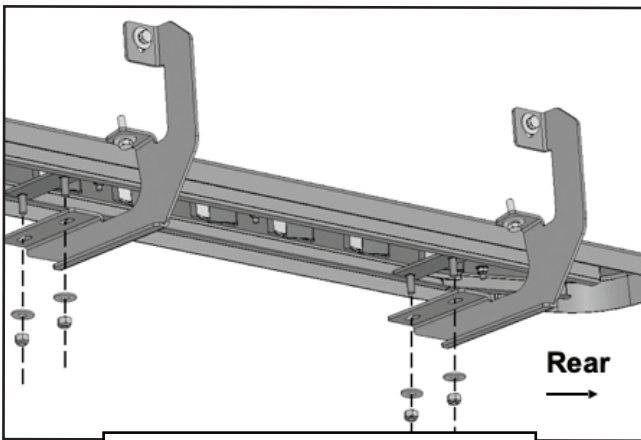

(Fig 13) Attach Running Board to #3 and the rear Mounting Brackets

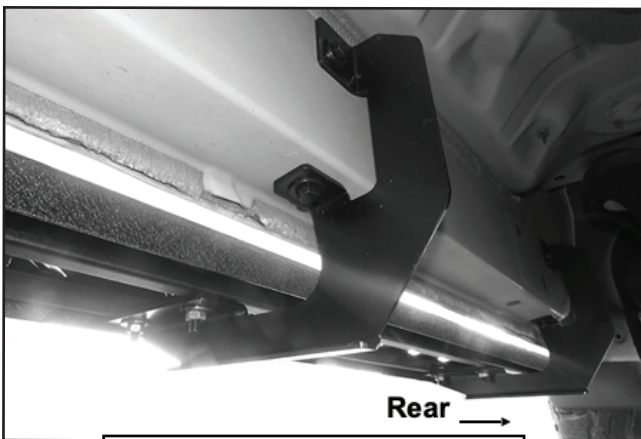

(Fig 14) Running Board attached to #3 and rear Mounting Brackets

STEP 8

Repeat **STEPS 1-7** to install the driver/left side Running Board. Measure the distance from passenger/right front wheel opening or mud flap to front end of Running Board (Fig 15). Match the driver/left Running Board to the passenger/right side installation.

Passenger/right side Installation Pictured

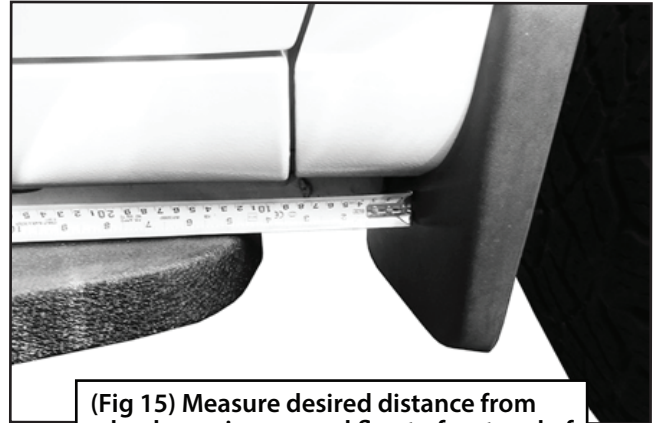

(Fig 15) Measure desired distance from wheel opening or mud flap to front end of Running Board. Match driver/left Running Board to passenger/right side installation

STEP 9

Do periodic inspections to the installation to make sure that all hardware is secure and tight.

STEP 7

Level and adjust the Running Board and fully tighten all hardware.