



TYGER BLADE

TG-BL7D7178

BEFORE INSTALLATION

READ INSTRUCTIONS CAREFULLY BEFORE STARTING INSTALLATION. REMOVE CONTENTS FROM BOX AND VERIFY ALL PARTS ARE PRESENT. FAILURE TO IDENTIFY DAMAGE BEFORE INSTALLATION COULD LEAD TO A REJECTION OF ANY CLAIM. IF MISSING PARTS OR ANY DAMAGE FOUND, PLEASE TAKE A PICTURE FOR THE CLAIM PURPOSE. TO FILE YOUR CLAIM, PLEASE VISIT: WWW.TYGERAUTO.COM/CONTACT

TORQUE VALUES

Fastener Size	Class 8.8 Torque (ft-lbs)	Class 10.9 Torque (ft-lbs)
6mm	6-7	6-7
8mm	15-16	22-23
10mm	31-32	44-45
12mm	54-55	78-79
14mm	87-88	125-126

- x2** TYGER Blade Running Boards (88in)
- x6** 8mm Double Bolt Plates
- x24** 8mm x 16mm x 1.5mm Small Flat Washers
- x6** Mounting Brackets (A)
- x12** 8-1.25mm x 25mm Hex Bolts
- x42** 8-1.25mm Nylon Lock Nuts
- x6** Mounting Bracket Base Plate (C)
- x30** 8mm x 24mm x 2mm Large Flat Washers

Parts List

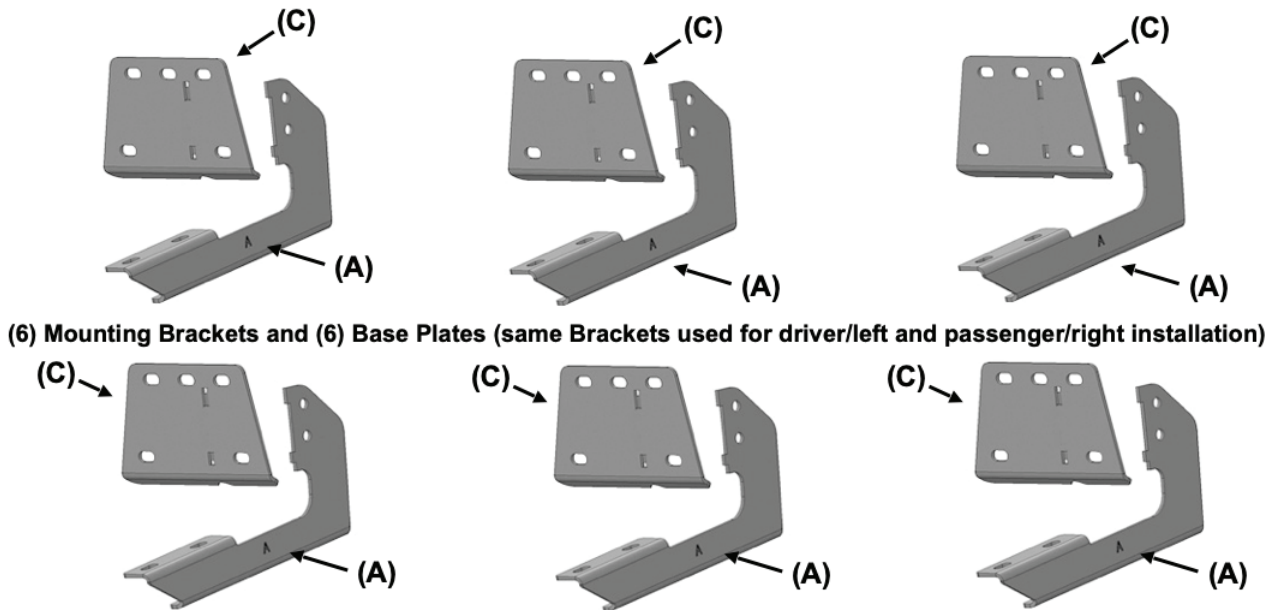

Bottom View Assembled Running Boards

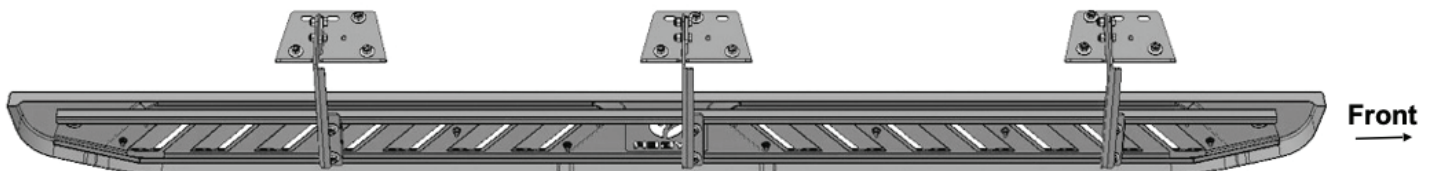

Driver/Left Running Board Assembly (Bottom View)

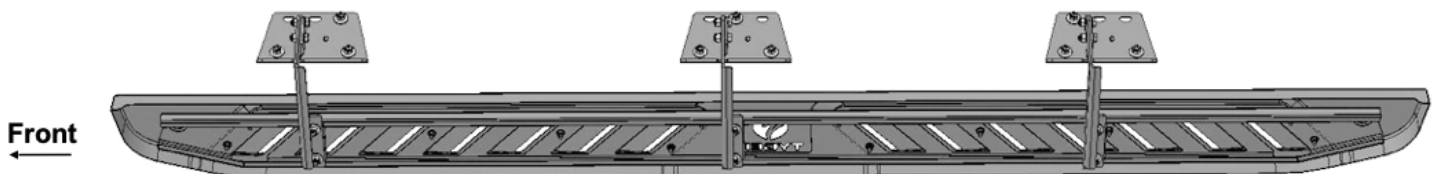

Passenger/Right Running Board Assembly (Bottom View)

PROCEDURE:

REMOVE CONTENTS FROM BOX. VERIFY ALL PARTS ARE PRESENT. READ INSTRUCTIONS CAREFULLY BEFORE STARTING INSTALLATION. ASSISTANCE IS RECOMMENDED.

STEP 1

Select (1) Mounting Bracket **(A)** and (1) Mounting Bracket Base Plate **(C)** (Fig 1). **NOTE:** All (6) Brackets are universal and will fit left or right side of the vehicle. Attach the Mounting Bracket **(A)** to the Base Plate **(C)** with the included (2) 8mm x 25mm Hex Bolts, (4) 8mm x 16mm Small Flat Washers and (2) 8mm Nylon Lock Nuts. Repeat this **STEP** to assemble the remaining (5) Mounting Brackets.

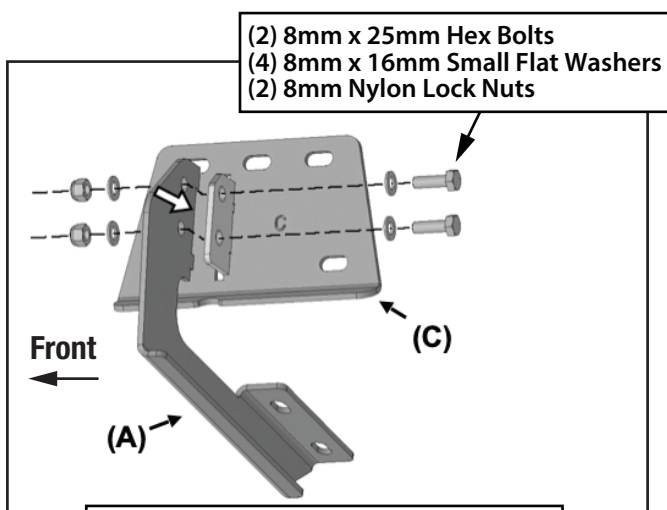
Passenger/right side Installation Pictured

(Fig 1) Attach the (6) Mounting Brackets to the (6) Bracket Base Plates

STEP 2

Move to the passenger/right side of the vehicle. Locate the front (3) factory studs along the inner side of the body panel (Fig 2). **IMPORTANT:** Use a wire brush or thread chaser die to remove excess paint or undercoating from threaded studs as necessary.

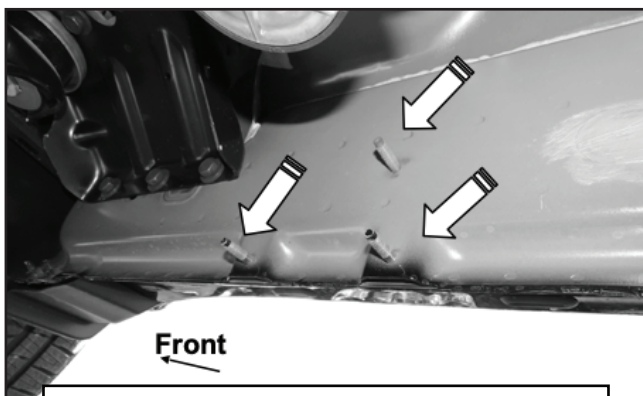
Passenger/right side Installation Pictured

(Fig 2) Passenger/right front mounting location

STEP 3

Attach (1) Bracket Assembly to the (3) factory studs with (3) 8mm x 24mm Large Flat Washers and (3) 8mm Nylon Lock Nuts (Figs 3 & 4). Leave Brackets loose at this time.

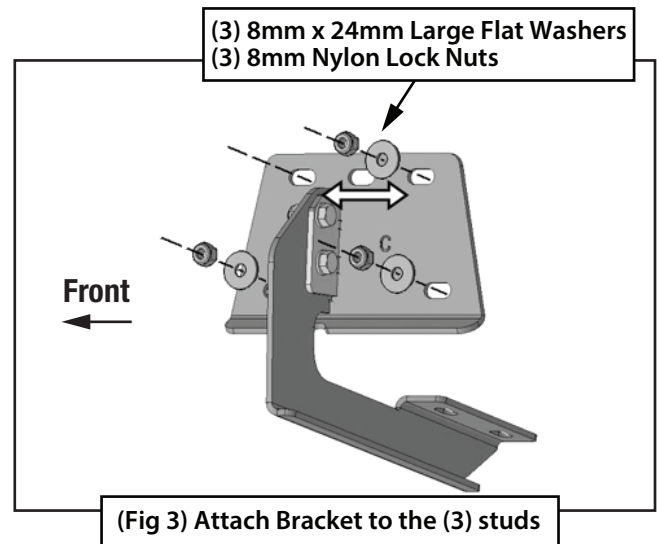
Passenger/right side Installation Pictured

(Fig 3) Attach Bracket to the (3) studs

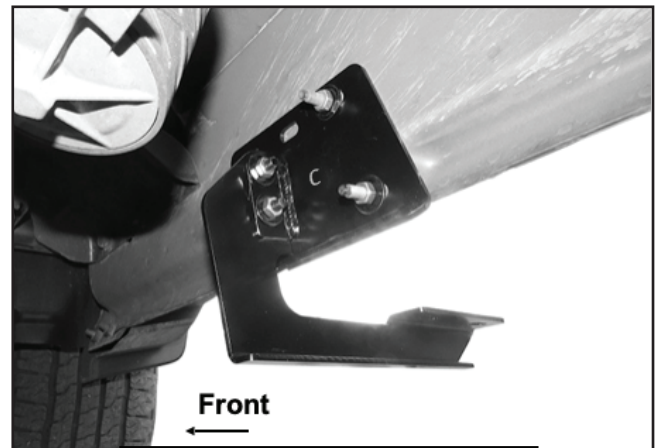

(Fig 4) Attach Mounting Bracket to passenger/right front location

STEP 4

Repeat **STEPS 2 & 3** to install the Mounting Brackets in the center and rear mounting locations along the body panel (Figs 5-7).

Passenger/right side Installation Pictured

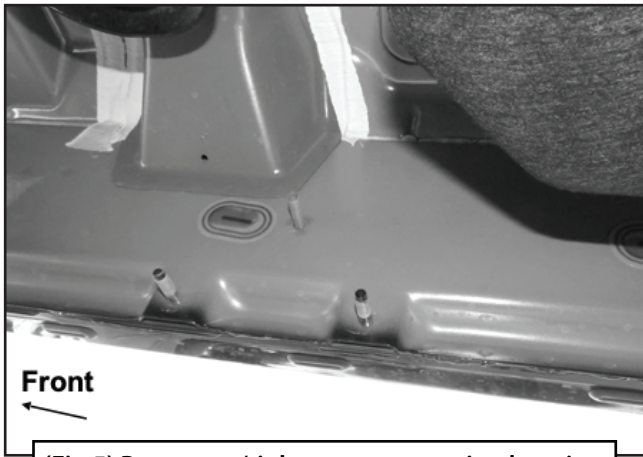

(Fig 5) Passenger/right center mounting location



(Fig 6) Passenger/right rear mounting location



(Fig 7) Attach Mounting Brackets to the passenger/right center and rear locations

STEP 5

Select (1) Running Board. Place the Running Board on top of the Brackets. Locate the channel in the bottom of the Running Board. Select (3) 8mm Double Bolt Plates. Insert the Bolt Plates into the channel in the bottom of the Running Board closest to the Brackets (Fig 8). Lift the Running Board up and guide the studs down through the Brackets (Fig 9).

Passenger/right side Installation Pictured

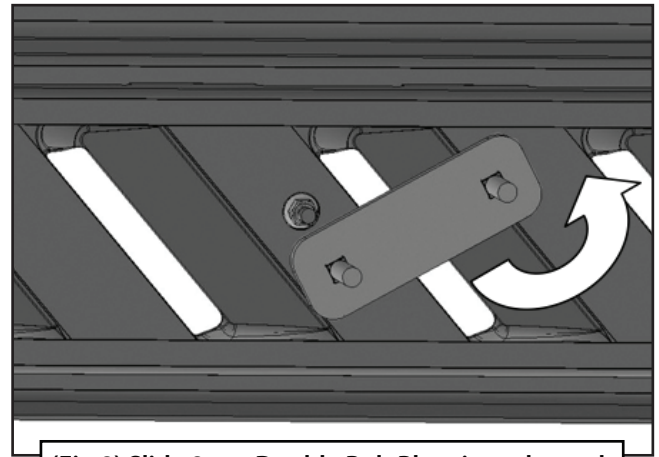

(Fig 8) Slide 8mm Double Bolt Plate into channel

(2) 8mm x 24mm Large Flat Washers
(2) 8mm Nylon Lock Nuts

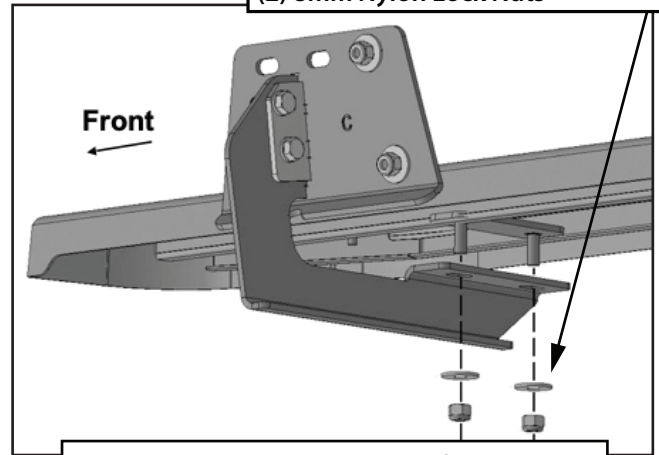

(Fig 9) Attach Running Board to front Bracket

STEP 6

Attach the Running Board to the Brackets with (6) 8mm x 24mm Large Flat Washers and (6) 8mm Nylon Lock Nuts (Figs 9-12). DO NOT tighten hardware at this time.

Passenger/right side Installation Pictured

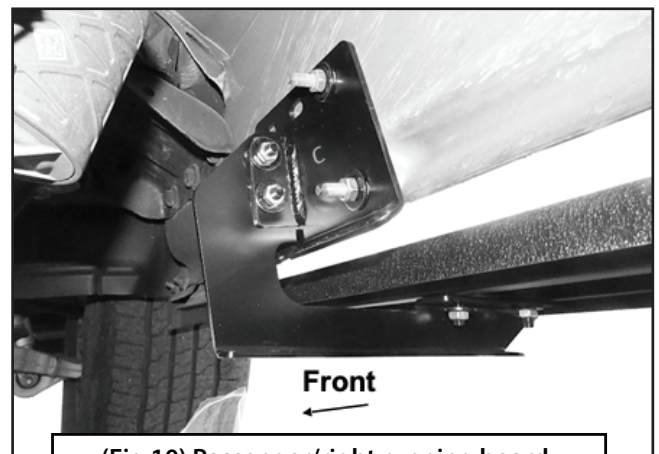

(Fig 10) Passenger/right running board attached to front Bracket



(Fig 11) Passenger/right running board attached to center Bracket

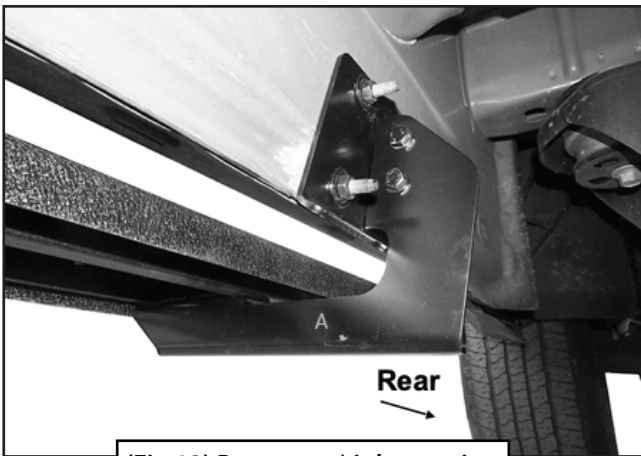

(Fig 12) Passenger/right running board attached to rear Bracket

STEP 7

Properly level and adjust the Running Board and fully tighten all hardware.

Passenger/right side Installation Pictured



Installation Complete

STEP 8

Repeat **STEPS 2-7** to install the driver/left side Running Board. Measure the distance from passenger/right front wheel opening or mud flap to front end of Running Board. Match the driver/left Running Board to the passenger/right side installation.

STEP 9

Do periodic inspections to the installation to make sure that all hardware is secure and tight.