



TYGER FURY BUMPER

TG-BP6D80368

BEFORE INSTALLATION

READ INSTRUCTIONS CAREFULLY BEFORE STARTING INSTALLATION. REMOVE CONTENTS FROM BOX AND VERIFY ALL PARTS ARE PRESENT. FAILURE TO IDENTIFY DAMAGE BEFORE INSTALLATION COULD LEAD TO A REJECTION OF ANY CLAIM. IF MISSING PARTS OR ANY DAMAGE FOUND, PLEASE TAKE A PICTURE FOR THE CLAIM PURPOSE. TO FILE YOUR CLAIM, PLEASE VISIT:

WWW.TYGERAUTO.COM/CONTACT

TORQUE VALUES

Fastener Size	Class 8.8 Torque (ft-lbs)	Class 10.9 Torque (ft-lbs)
6mm	6-7	6-7
8mm	15-16	22-23
10mm	31-32	44-45
12mm	54-55	78-79
14mm	87-88	125-126

- x1** TG1 Front Bumper Assembly
- x1** Driver/left Top Cover Plate
- x1** Passenger/right Top Cover Plate
- x1** Bumper Hoop
- x1** Driver/Left Mounting Bracket
- x1** Passenger/Right Mounting Bracket
- x2** LED Light "L" Brackets
- x1** License Plate Brackets
- x2** Plastic License Plugs
- x2** 12-1.75mm x 35mm Bolt Plate
- x12** 12mm x 32mm x 3mm Flat Washers
- x8** 12mm Lock Washers
- x8** 12-1.75mm Hex Nuts
- x4** 12-1.75mm x 35mm Hex Bolts
- x2** 10-1.50mm x 35mm Hex Bolts
- x4** 10mm x 27mm x 3mm Flat Washer
- x2** 10mm Lock Washer
- x2** 10-1.50mm Hex Nuts
- x6** 8-1.25mm x 25mm Button Head Bolt
- x14** 8mm x 24mm x 2mm Flat Washers
- x8** 8mm Lock Washers
- x6** 8mm Hex Nuts
- x2** 8mm x 1.25mm x 16mm Hex Bolts
- x6** 6-1.0mm x 20mm Combo Button Head Bolts
- x2** 6-1.0mm x 20mm Button Head Bolts
- x4** 6mm x 18mm x 1.6mm Flat Washers
- x2** 6mm Nylon Lock Nuts
- x1** 4mm Wrench
- x1** 5mm Wrench

Parts List

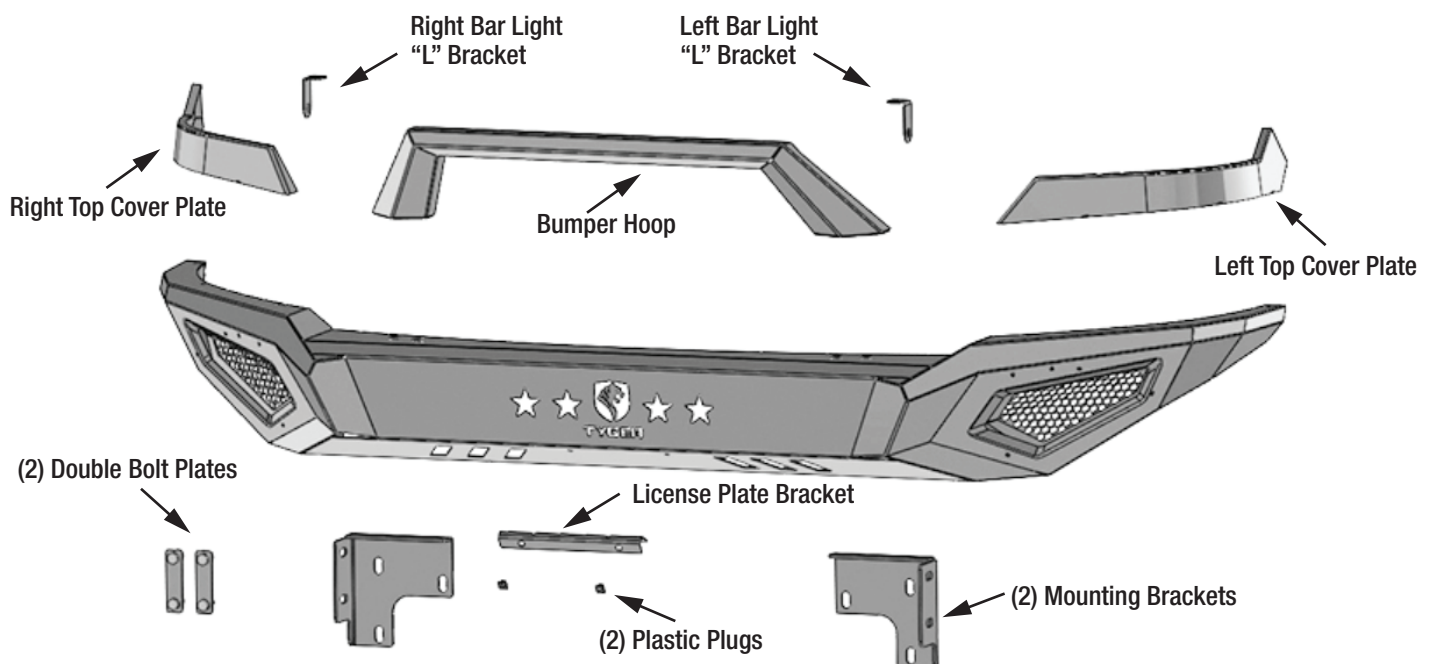

PROCEDURE:

REMOVE CONTENTS FROM BOX. VERIFY ALL PARTS ARE PRESENT. READ INSTRUCTIONS CAREFULLY BEFORE STARTING INSTALLATION. BUMPER IS HEAVY, ASSISTANCE IS HIGHLY RECOMMENDED TO AVOID POSSIBLE INJURY OR DAMAGE TO THE VEHICLE.

STEP 1

Remove the license plate and bracket (keep the hardware to be reused). Remove lower air dam (Fig 1). **NOTE:** Air dam is attached with many 2pc retaining clips. Pry up center of pin to release and remove clips.

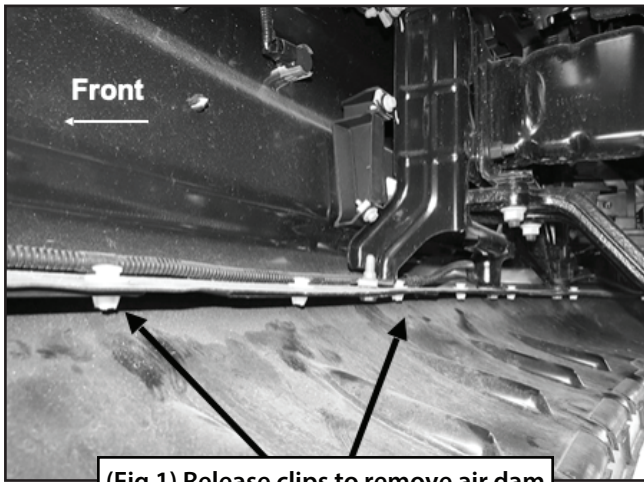

(Fig 1) Release clips to remove air dam

STEP 2

On models with factory fog lights and/or sensors, unplug wiring harness leading to bumper (Fig 2). Move harness away from bumper.

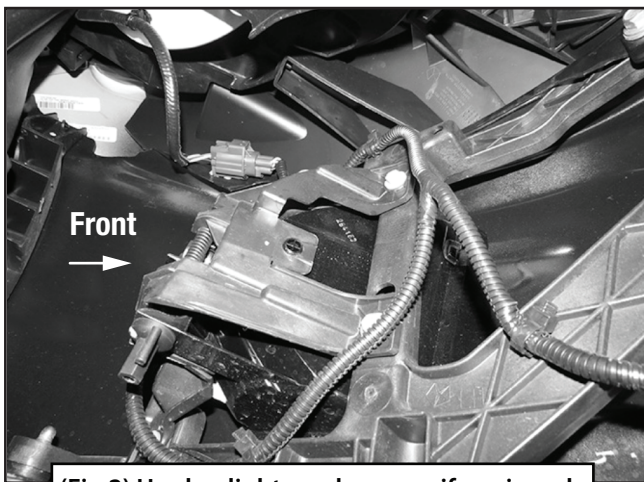

(Fig 2) Unplug lights and sensors if equipped. Unplug harness to bumper and move harness

STEP 3

Next, remove the plastic fascia (plastic fill panel) between the headlights and the top of the bumper (Fig 3). **NOTE:** Release inner fender liner to access hardware attaching the ends of fascia panel to the bottom of the front fenders (Figs 3 & 4). On some model years, it may be necessary to temporarily remove the grille to remove the fascia or 1pc plastic bumper cover.

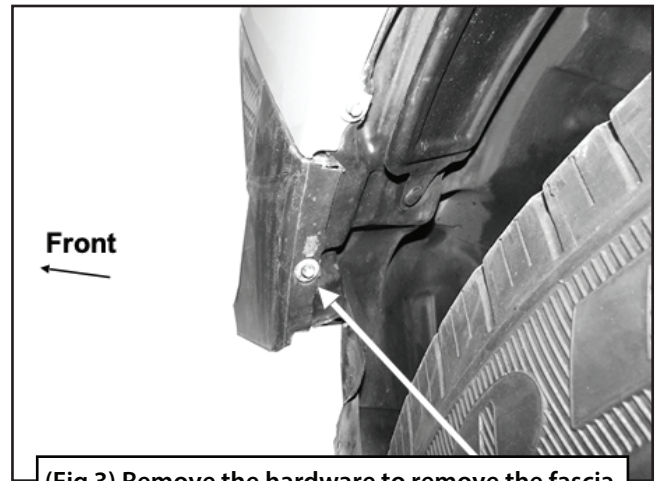

(Fig 3) Remove the hardware to remove the fascia

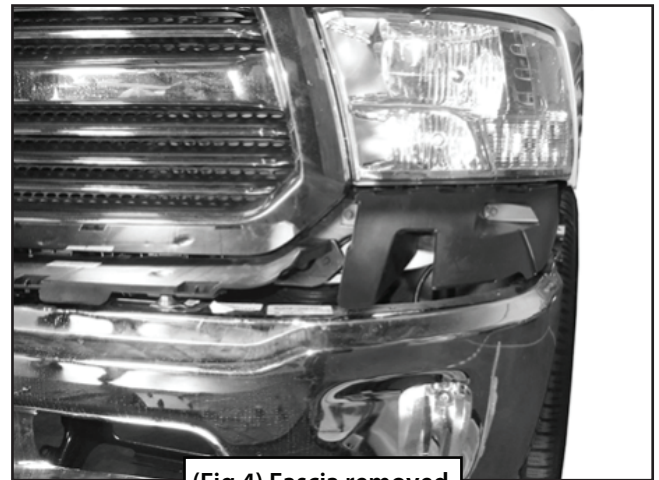

(Fig 4) Fascia removed

STEP 4

Place blocks or jack stands under the bumper to support it during mounting bolt removal. Once the bumper has been safely supported, remove the (3) hex nuts attaching each bumper bracket to the end of the frame (Fig 5). **WARNING!** Assistance is required to hold bumper in place during hardware removal to prevent the bumper from falling. On models with tow hooks, remove the (2) hex nuts attaching the L bracket for the tow hooks to the back of the bumper bracket (Fig 6). Temporarily remove tow hooks.

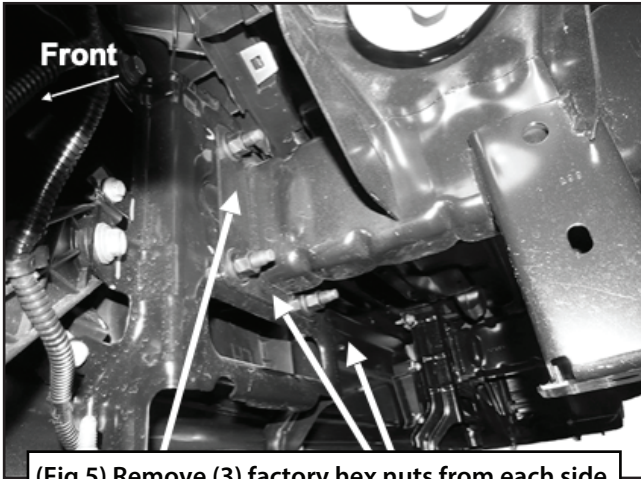

(Fig 5) Remove (3) factory hex nuts from each side

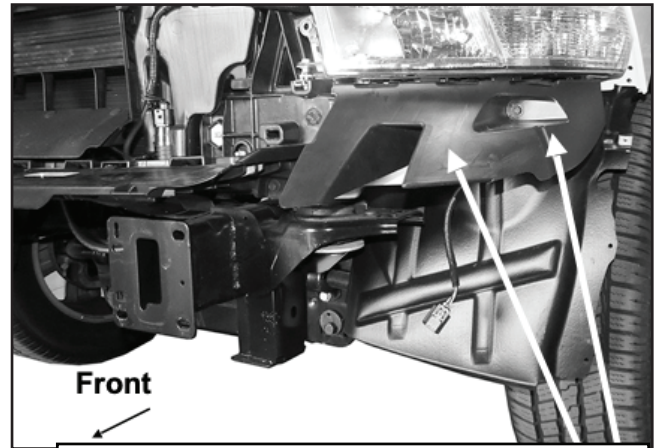

(Fig 7) Remove plastic block from below headlight

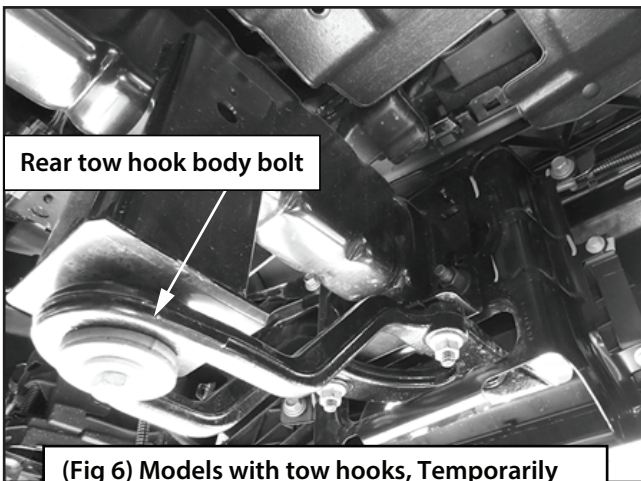

Rear tow hook body bolt

(Fig 6) Models with tow hooks, Temporarily remove the tow hooks and place in a safe area

STEP 7

If front license plate is required, attach the License Plate Bracket to the holes in the bumper with the included (2) 6mm x 20mm Button Head Screws, (4) 6mm x 18mm Large Flat Washers and (2) 6mm Nylon Lock Nuts. Insert (2) Plastic Plugs into the square holes in the Bracket (Figs 8 & 9).

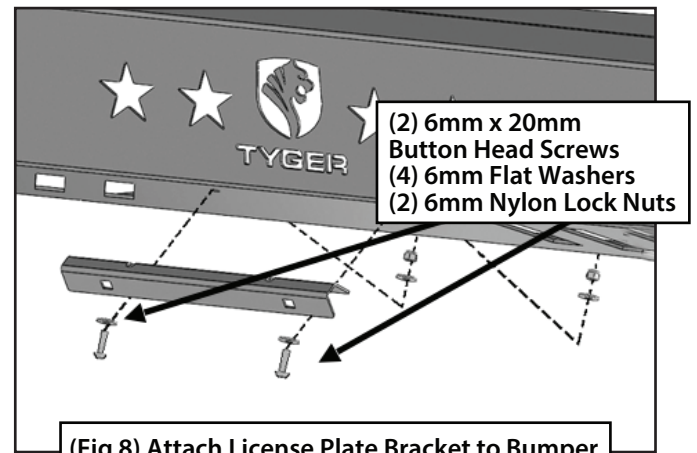

(Fig 8) Attach License Plate Bracket to Bumper

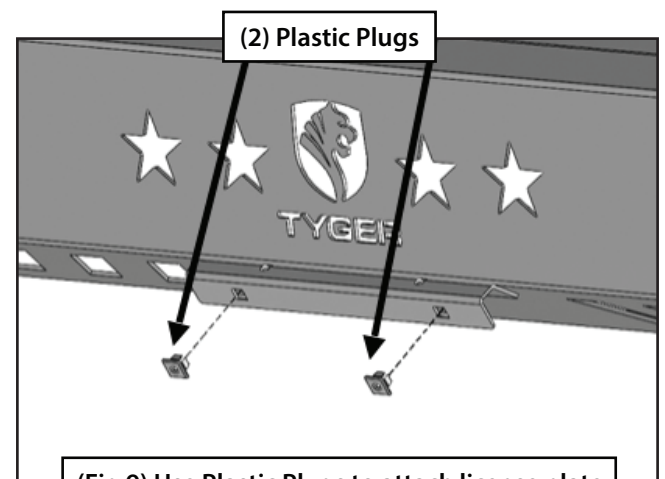

(Fig 9) Use Plastic Plugs to attach license plate

STEP 5

Slide the bumper assembly off of the end of the frame and tow hooks if equipped.

STEP 6

Next, remove the plastic inner support blocks from the bottom of the headlights (Fig 7).

STEP 8

Carefully unwrap the Bumper assembly. Determine if accessory lights, (not included) will be installed at this time. Remove the mesh fill panels by removing the three bolts holding them in place (Fig 10).

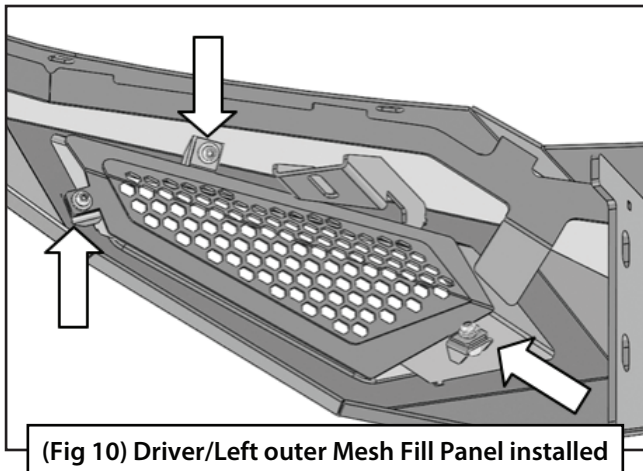

STEP 9

Select the Bumper Hoop. Attach to top of the Bumper with (4) 8mm x 25mm Button Head Bolts, (8) 8mm Flat Washers, (4) 8mm Lock Washers and (4) 8mm Hex Nuts (Fig 11). DO NOT fully tighten hardware at this time.

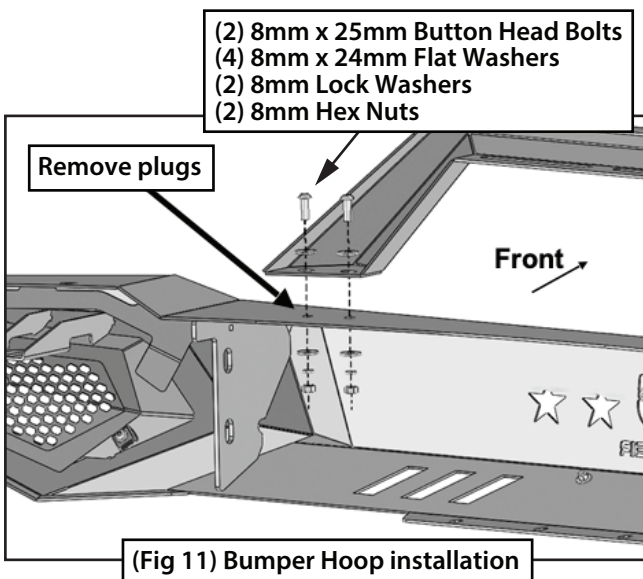

STEP 10

Outer LED cube style light installation (light not included).

- Attach lights to mounting tabs at the outer-ends of the Bumper (Fig 12).
- Follow the light manufacturer's instructions to properly wire lights once Bumper is installed.

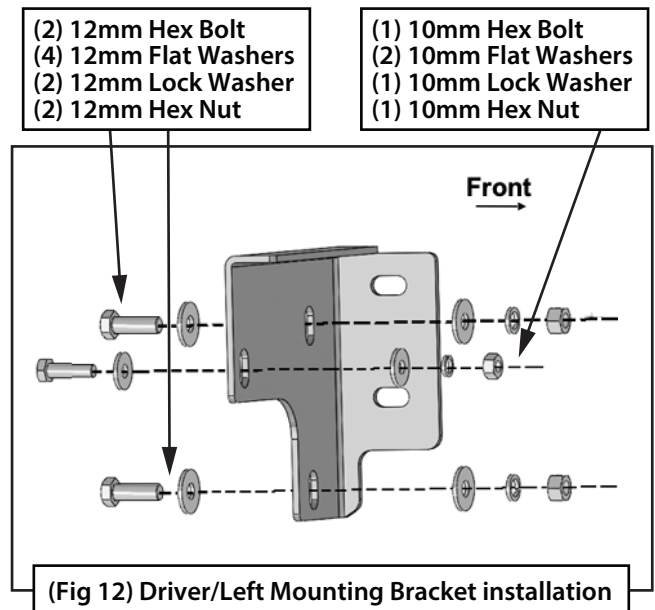

STEP 11

Hoop center LED bar style light installation (light not included).

- Select (1) L Light Bar Bracket.
- Attach the L Bracket to the slot on the back of the Bumper with (1) 8mm x 25mm Button Head Bolt, (2) 8mm Flat Washers, (1) 8mm Lock Washer and (1) 8mm Hex Nut (Fig 13). Repeat this Step to install the remaining L Bracket on the other side of the Bumper.
- Attach the light to the L Brackets with the hardware included with the light or the supplied (2) 8mm x 16mm Hex Bolts, (2) 8mm Lock Washers and (2) 8mm Flat Washers (Fig 14). DO NOT fully tighten hardware at this time.

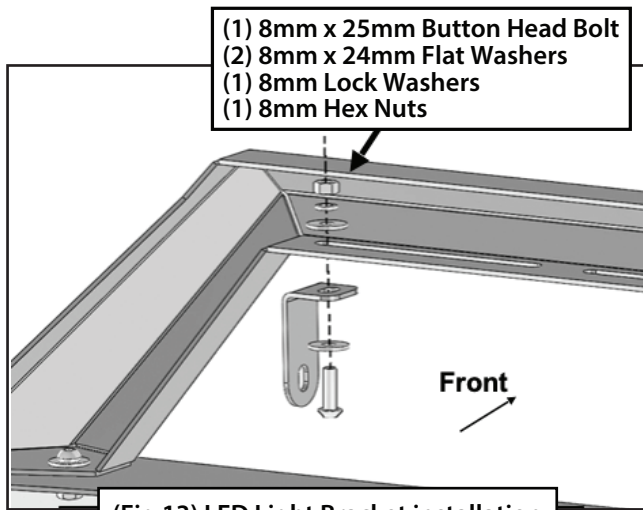

(Fig 13) LED Light Bracket installation

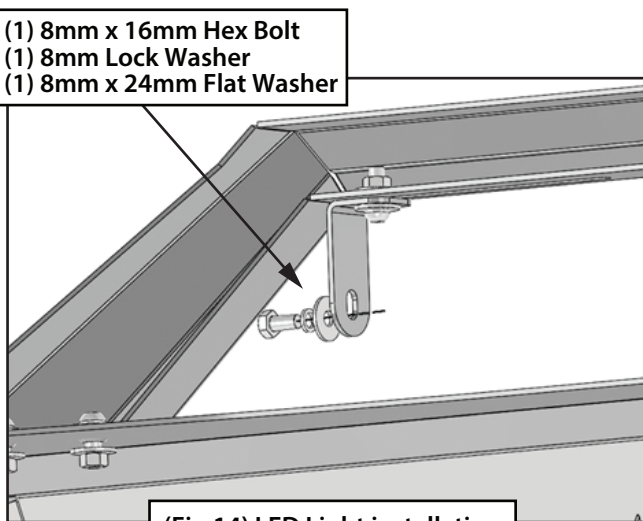

(Fig 14) LED Light installation

STEP 12

Select the Driver/Left Top Cover Plate. Attach to top of Bumper with (3) 6mm Combo Bolts. Repeat this step for the Passenger /Right (Fig 15).

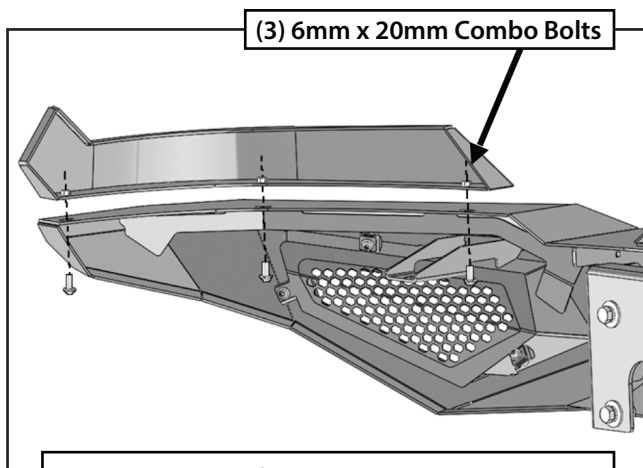

(Fig 15) Driver/Left Top Cover Panel installation

STEP 13

Select the Driver/Left Mounting Bracket. Attach Bracket to the frame mounting location (Fig 16), with (2) 12mm Hex Bolts, (4) 12mm Flat Washers, (2) 12mm Lock Washers, (2) 12mm Hex Nuts, (1) 10mm Hex Bolt, (2) 10mm Flat Washers, (1) Lock Washer and (1) 10mm Hex Nut (Figs 12 & 17).

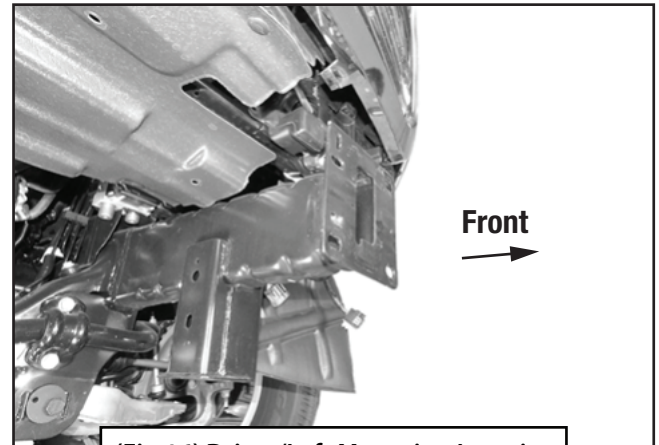

(Fig 16) Driver/Left Mounting Location

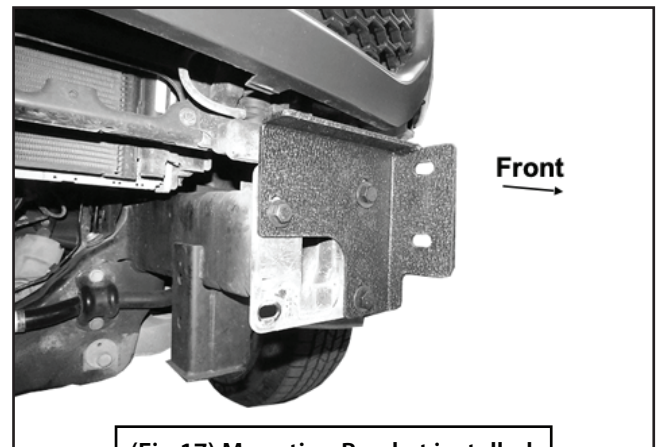

(Fig 17) Mounting Bracket installed

STEP 14

With assistance, position the TG1 Bumper Assembly on the outside of the Mounting Brackets. Temporarily support the weight of the Bumper. **WARNING:** To avoid possible injury or damage to the vehicle, do not proceed until the Bumper is fully and safely supported. **NOTE:** It may be easier to install accessory lights before installing the Bumper.

STEP 15

Select (1) 12mm Double Bolt Plate. Slide the Bolt Plate into the holes in the Driver/Left side of the Bracket and the Bumper. Secure Bumper to the frame with (2) 12mm Flat Washers, (2) 12mm Lock Washers and (2) 12mm Hex Nuts (Figs 18 & 19). DO NOT fully tighten at this time.

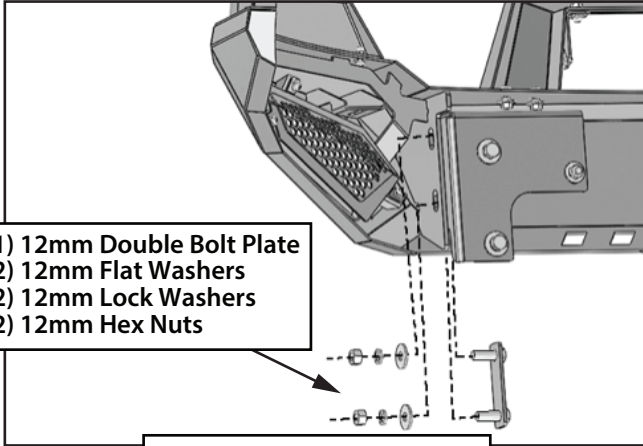

- (1) 12mm Double Bolt Plate
- (2) 12mm Flat Washers
- (2) 12mm Lock Washers
- (2) 12mm Hex Nuts

(Fig 18) Bumper installation

- (1) 12mm Double Bolt Plate
- (2) 12mm Flat Washers
- (2) 12mm Lock Washers
- (2) 12mm Hex Nuts



(Fig 19) Bracket Installed

STEP 16

Repeat **STEP 15** for the Passenger/Right side.

STEP 17

For models equipped with tow hooks. Reattach to the rear of the tow hook to the bottom of the frame stud with the factory body bolt. Then attach the (2) holes in the upper hook to the bottom of the Mounting Brackets with the 12mm hardware from **STEP 10** (Fig 6 & 20).

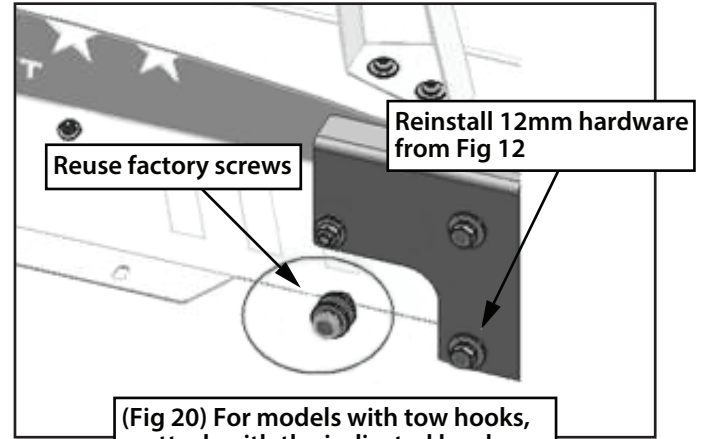

(Fig 20) For models with tow hooks, reattach with the indicated hardware

STEP 18

Reuse the factory screws to attach the license plate to the plastic plugs.

STEP 19

Level and adjust the bumper and fully tighten all hardware.



Installation Complete

STEP 20

Do periodic inspections to the installation to make sure that all hardware is secure and tight.