



# TYGER FRONT BUMPER

TG-BP7T20778

## BEFORE INSTALLATION

READ INSTRUCTIONS CAREFULLY BEFORE STARTING INSTALLATION. REMOVE CONTENTS FROM BOX AND VERIFY ALL PARTS ARE PRESENT. FAILURE TO IDENTIFY DAMAGE BEFORE INSTALLATION COULD LEAD TO A REJECTION OF ANY CLAIM. IF MISSING PARTS OR ANY DAMAGE FOUND, PLEASE TAKE A PICTURE FOR THE CLAIM PURPOSE. TO FILE YOUR CLAIM, PLEASE VISIT: [WWW.TYGERAUTO.COM/CONTACT](http://WWW.TYGERAUTO.COM/CONTACT)

## TORQUE VALUES

Fastener Size	Class 8.8 Torque (ft-lbs)	Class 10.9 Torque (ft-lbs)
6mm	6-7	6-7
8mm	15-16	22-23
10mm	31-32	44-45
12mm	54-55	78-79
14mm	87-88	125-126

- x1 TYGER Center Bumper
- x1 Winch Tray Assembly
- x1 Skid Plate
- x1 Bull Nose
- x1 Driver/left Mounting Bracket
- x1 Passenger/right Mounting Bracket
- x1 Driver/left Support Bracket
- x1 Passenger/right Support Bracket
- x1 License Plate Bracket
- x2 Plastic Plugs for License Plate
- x1 Foam for A/C line
- x4 Relocation Wedges
- x1 1700mm Edge Trim
- x10 Zip ties (2.75 x 1x 200)
- x2 6-1.0mm x 40mm Hex Bolts
- x3 8-1.25mm x 25mm Hex Bolts
- x2 10-1.5mm x 40mm Hex Bolts
- x2 12-1.25mm x 30mm Hex Bolts
- x6 12-1.75mm x 40mm Hex Bolts
- x2 8-1.25mm x 16mm Hex Bolts
- x2 6mm x 12mm x 1.6mm Flat Washers
- x16 8mm x 24mm x 2mm Flat Washers
- x4 10mm x 20mm x 2mm Flat Washers
- x4 10mm x 30mm x 2.5mm Flat Washers
- x8 12mm x 24mm x 2.5mm Flat Washers
- x2 6mm Lock Washers
- x6 8mm Lock Washers
- x2 10mm Lock Washers
- x8 12mm Lock Washers
- x4 8mm Hex Nuts
- x2 10mm Hex Nuts
- x3 8mm Nylon Lock Nuts
- x2 10mm Nylon Lock Nuts
- x4 8-1.25mm x 25mm Button Head Bolts
- x2 10mm x 1.5mm x 30mm Button Head Bolts
- x5 6-1.0mm x 20mm Button Head Combo Bolts
- x1 4mm Hex Key
- x1 5mm Hex Key
- x1 6mm Hex Key

## Parts List

**Bull Nose**

**Winch Tray**

**Center Bumper (Mesh Cover Installed)**

**Skid Plate**

**License Plate Bracket**

**Driver/Left Support Bracket**

**Passenger/Right Support Bracket**

**Driver/Left Mounting Bracket**

**Passenger/Right Mounting Bracket**

**Driver/Left L Bracket (Pre-installed)**

**Passenger/Right L Bracket (Pre-installed)**

**x4 Relocation Wedge**

**4mm Hex Key**

**5mm Hex Key**

**6mm Hex Key**

**x2 6mm x 12mm x 1.6mm Flat Washers**

**x16 8mm x 24mm x 2mm Flat Washers**

**x4 10mm x 20mm x 2mm Flat Washers**

**x4 10mm x 30mm x 2.5mm Flat Washers**

**x8 12mm x 24mm x 2.5mm Flat Washers**

**x2 6mm Lock Washer**

**x6 8mm Lock Washer**

**x2 10mm Lock Washer**

**x8 12mm Lock washers**

**x4 8mm Hex Nuts**

**x2 10mm Hex Nuts**

**x3 8mm Nylon Lock Nuts**

**x2 10mm Nylon Lock Nuts**

**x4 8-1.25mm x 25mm Button Head Bolts**

**x2 10mm x 1.5mm x 30mm Button Head Bolts**

**x5 6-1.0mm x 20mm Button Head Combo Bolts**

## TOOLS REQUIRED

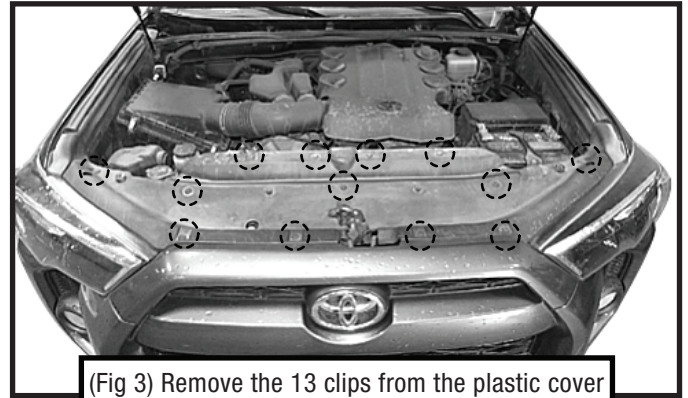
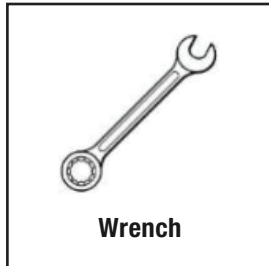
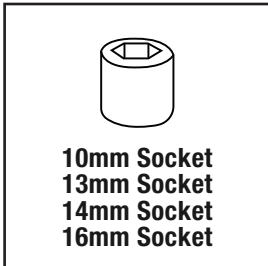
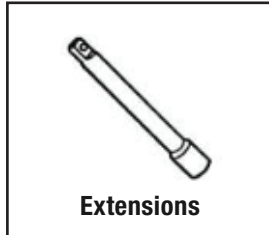
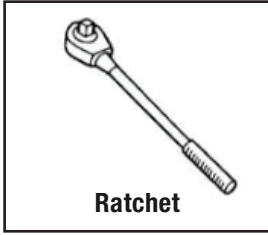

(Fig 3) Remove the 13 clips from the plastic cover on top of radiator to remove the cover

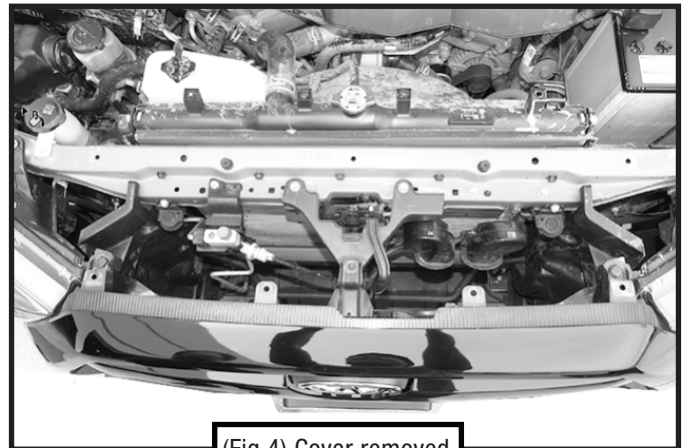

(Fig 4) Cover removed

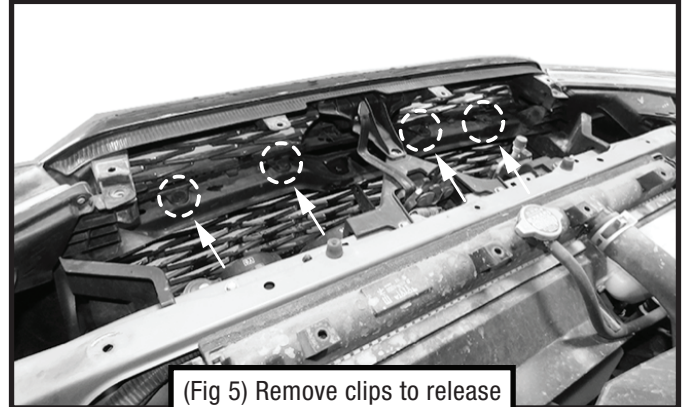

(Fig 5) Remove clips to release grille from cross member

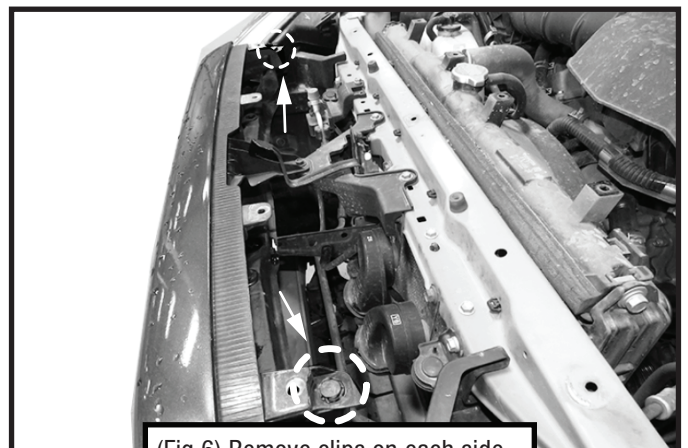

(Fig 6) Remove clips on each side to release grille from upper section

## STEP 1 REMOVE FACTORY FRONT BUMPER ASSEMBLY

Follow (Figs 1 – 12) to remove Front Bumper Assembly.

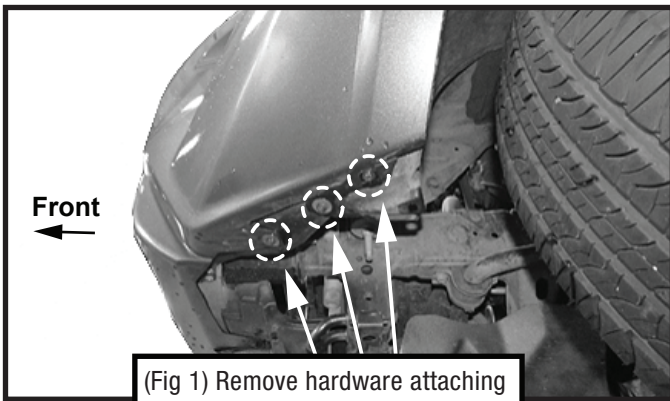

(Fig 1) Remove hardware attaching bottom of plastic bumper cover

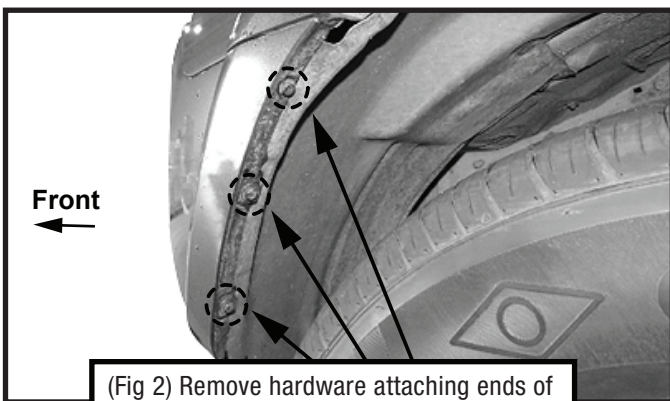

(Fig 2) Remove hardware attaching ends of plastic bumper cover along wheel openings



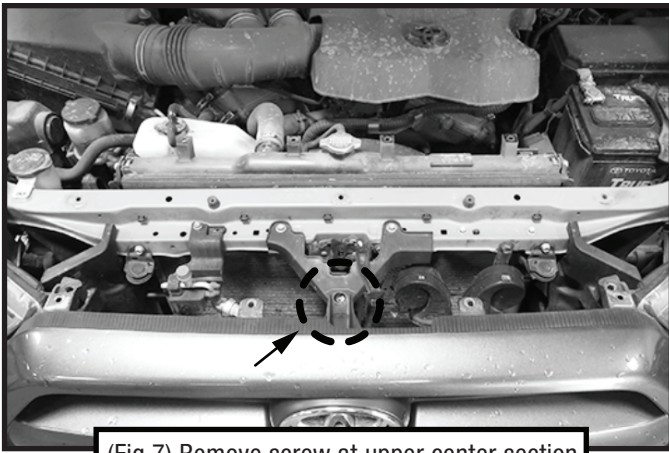

(Fig 7) Remove screw at upper center section

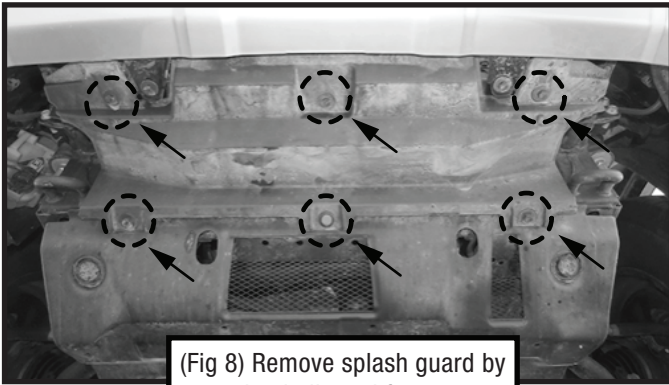

(Fig 8) Remove splash guard by removing indicated fasteners



(Fig 9) Carefully remove bumper by starting at sides and moving towards center



(Fig 10) Remove crash bar and frame extensions by uninstalling four factory bolts from the bracket face plate shown in (Fig 13)

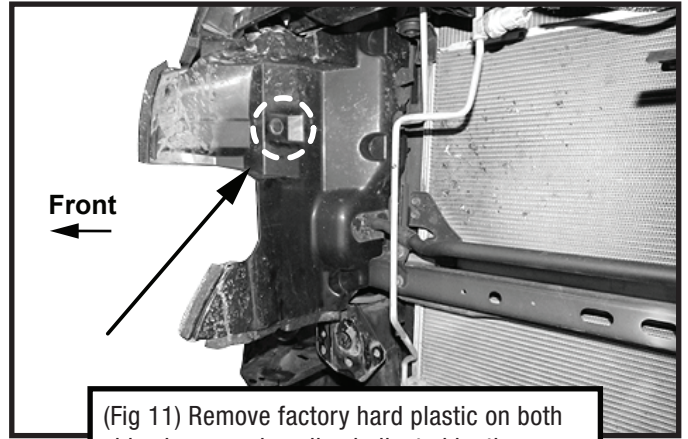

(Fig 11) Remove factory hard plastic on both sides by removing clips indicated by the arrow

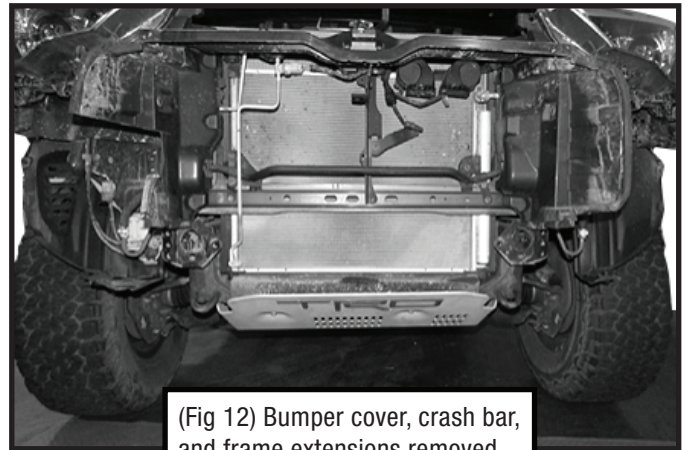

(Fig 12) Bumper cover, crash bar, and frame extensions removed



(Fig 12a) Optional: Use provided Zip Ties to organize any wiring and tubing as needed.

## STEP 2 WINCH TRAY & A/C LINE

Follow (Figs 13 – 16) to install Winch Tray and relocate AC Line.

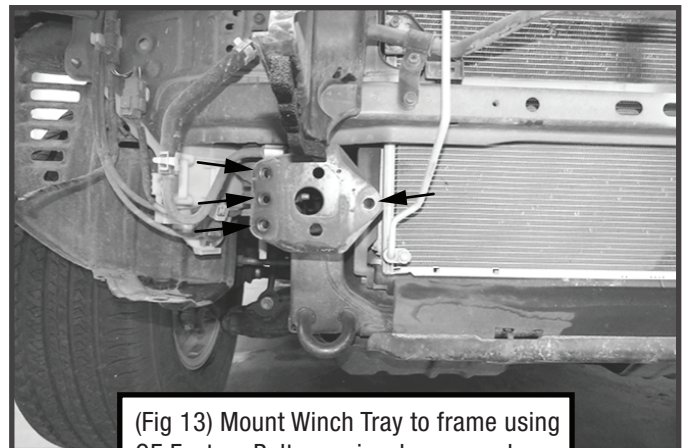

(Fig 13) Mount Winch Tray to frame using OE Factory Bolts previously removed. Mount winch onto tray if available.



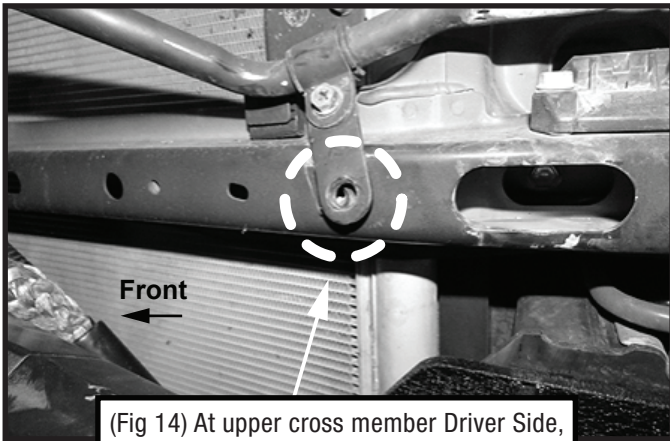

(Fig 14) At upper cross member Driver Side, remove bolts holding AC line bracket.

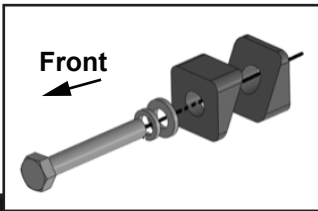

- (1) 6mm x 40mm Hex Bolt
- (1) 6mm Lock Washer
- (1) 6mm x 12mm x 1.6mm Flat Washer
- (2) Relocation Wedges

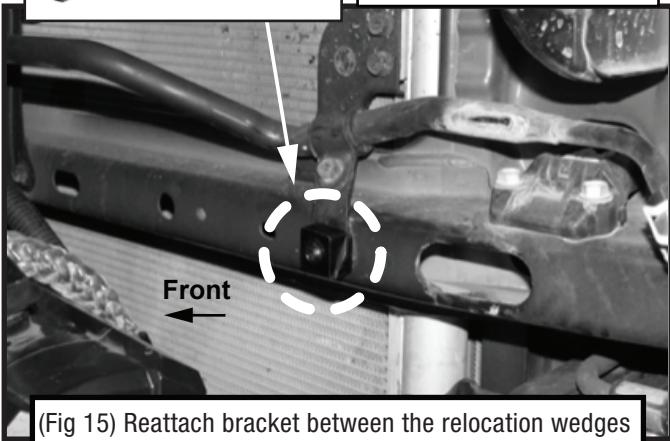

(Fig 15) Reattach bracket between the relocation wedges and fasten with replacement hex bolt (Driver Side)

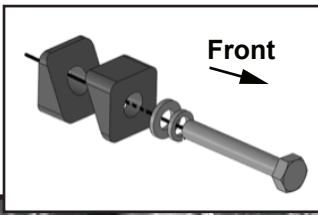

- (1) 6mm x 40mm Hex Bolt
- (1) 6mm Lock Washer
- (1) 6mm x 12mm x 1.6mm Flat Washer
- (2) Relocation Wedges

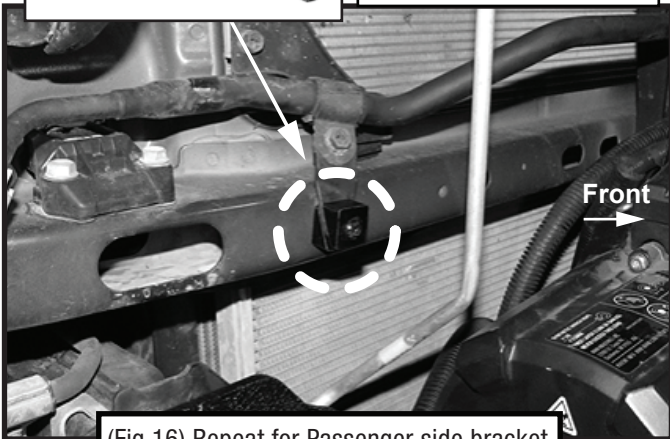

(Fig 16) Repeat for Passenger side bracket

### STEP 3 TRIMMING BUMPER COVER

Follow (Figs 17 - 21) to trim off Lower section of the Factory Bumper Cover.

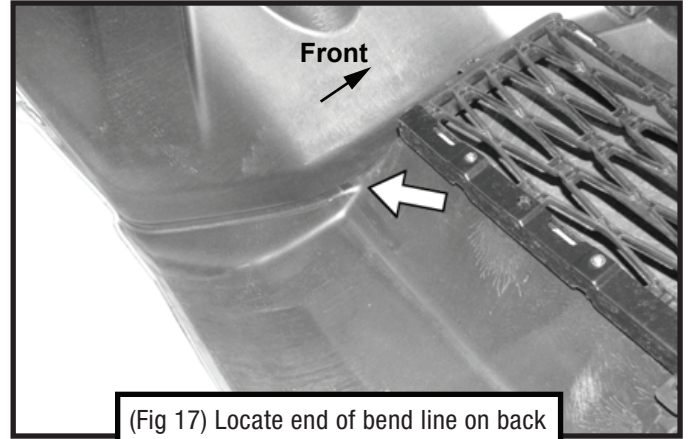

(Fig 17) Locate end of bend line on back of plastic bumper cover (Driver/Left)

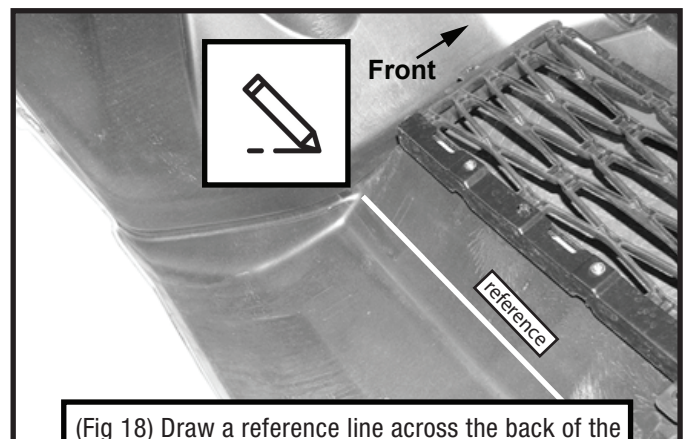

(Fig 18) Draw a reference line across the back of the cover connecting the two points pictured

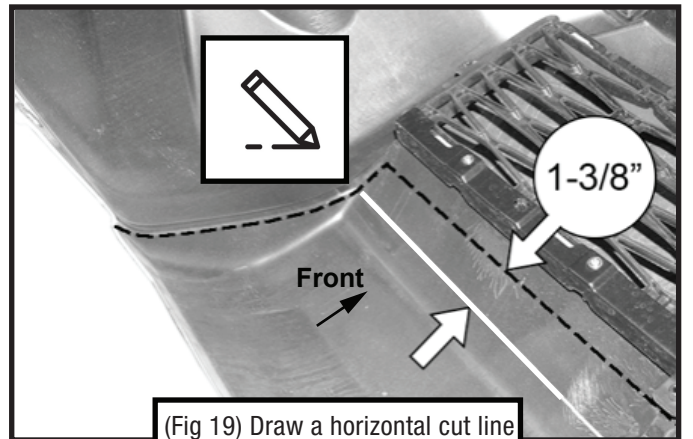

(Fig 19) Draw a horizontal cut line 1-3/8" above the reference line



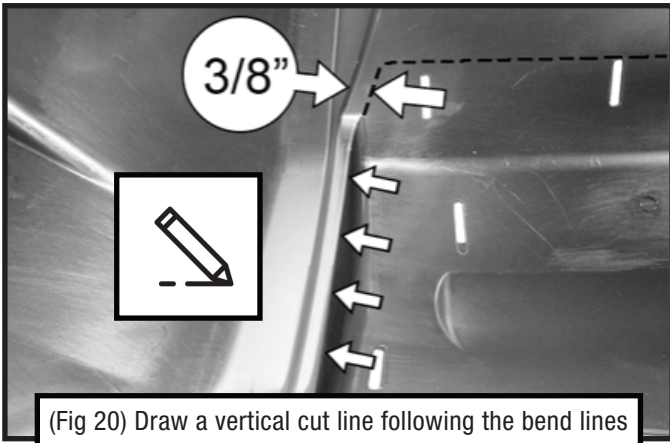

(Fig 20) Draw a vertical cut line following the bend lines (along the arrows) and up to the horizontal cut line

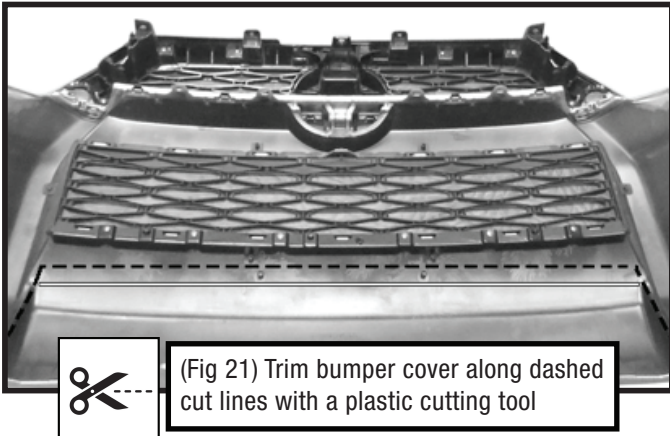

(Fig 21) Trim bumper cover along dashed cut lines with a plastic cutting tool

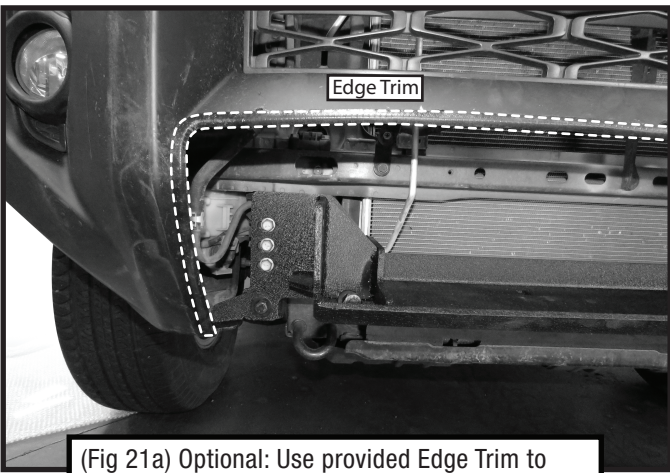

(Fig 21a) Optional: Use provided Edge Trim to seal any sharp edges as a result of the trimming.

## STEP 4 INSTALLING MOUNTING BRACKETS

Follow (Figs 22 - 33) to mount the Brackets and reinstall the Bumper Cover.

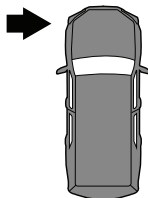

(Fig 22) Remove tape covering threaded hole in end of crossmember on both sides

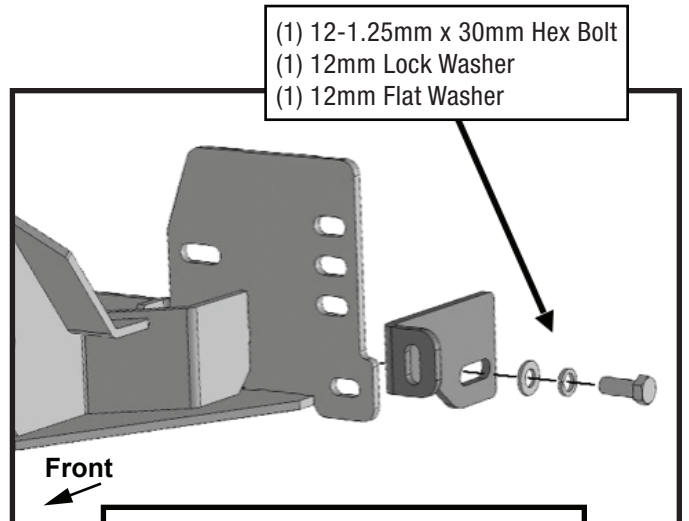

(Fig 23) Attach Driver/Left Mounting Bracket to threaded hole in crossmember

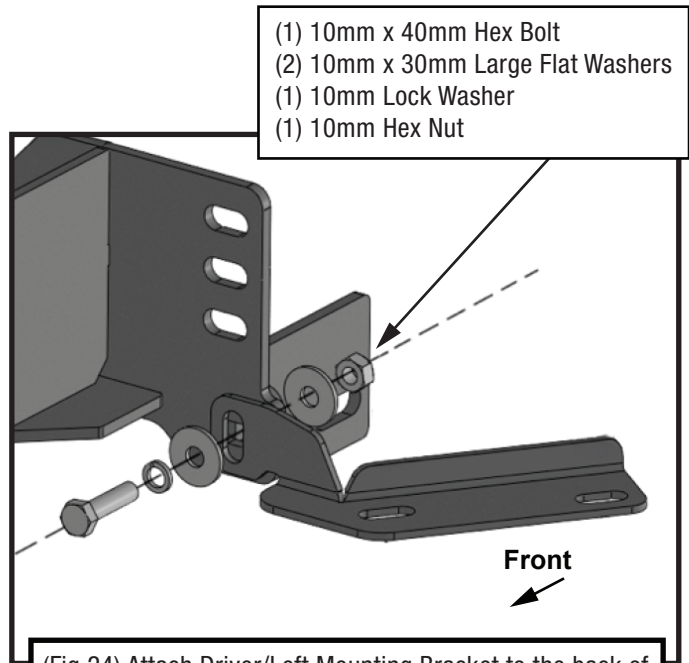

(Fig 24) Attach Driver/Left Mounting Bracket to the back of the Winch Tray and the Support Bracket to the front of it

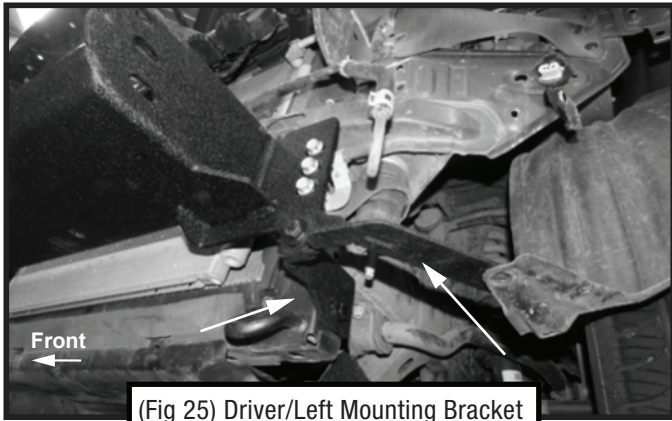

(Fig 25) Driver/Left Mounting Bracket and Support Bracket installed

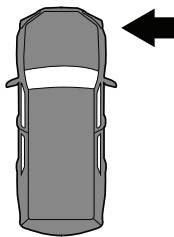

- (1) 12-1.25mm x 30mm Hex Bolt
- (1) 12mm Lock Washer
- (1) 12mm Flat Washer

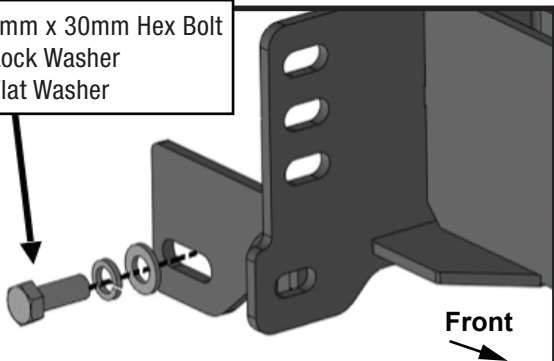

(Fig 26) Attach Passenger/Right Mounting Bracket to threaded hole in crossmember

- (1) 10mm x 40mm Hex Bolt
- (2) 10mm x 30mm Large Flat Washers
- (1) 10mm Lock Washer
- (1) 10mm Hex Nut

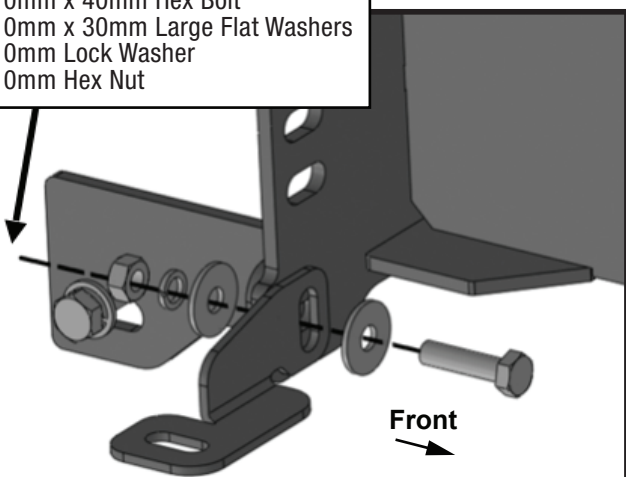

(Fig 27) Attach Passenger/Right Mounting Bracket to the back of the Winch Tray and the Support Bracket to the front of it



(Fig 28) Passenger/Right Mounting Bracket and Support Bracket installed



(Fig 29) Carefully reinstall the plastic bumper cover with original hardware in front of Winch Tray

- (1) 8mm x 25mm Hex Bolt
- (2) 8mm x 24mm Flat Washers
- (1) 8mm Nylon Lock Nut

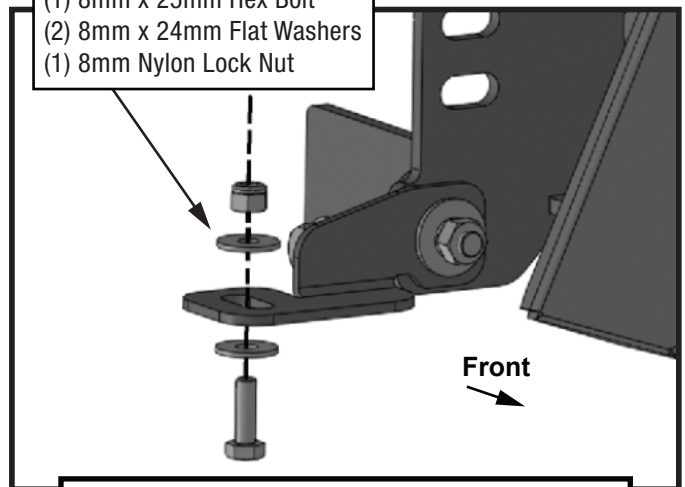

(Fig 30) Bolt together the Wheel Well Liner, Passenger/Right Support Bracket, and Bumper Cover

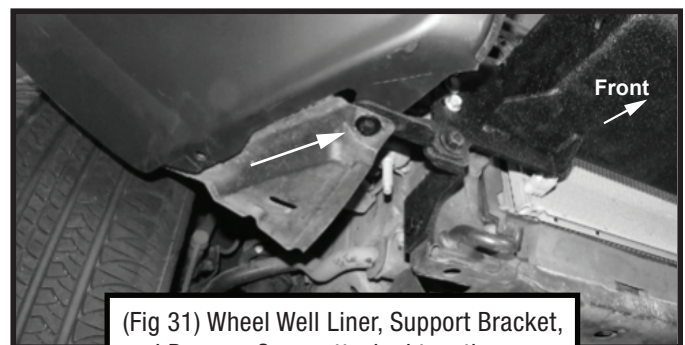

(Fig 31) Wheel Well Liner, Support Bracket, and Bumper Cover attached together



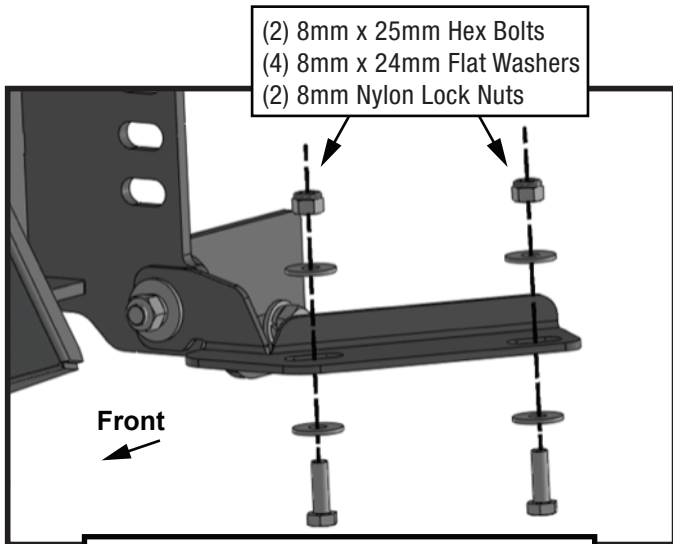
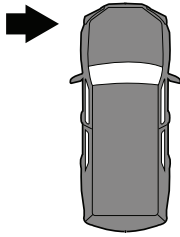

(Fig 32) Bolt together the Wheel Well Liner, Driver/Left Support Bracket, and Bumper Cover

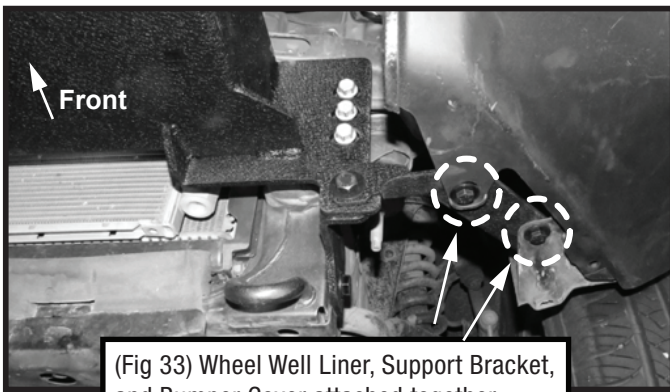

Pre-installed  
(not counted in the parts list)

- (1) 8mm x 25mm Hex Bolt
- (2) 8mm x 24mm Flat Washers
- (1) 8mm Lock Washer
- (1) 8mm Hex Nut

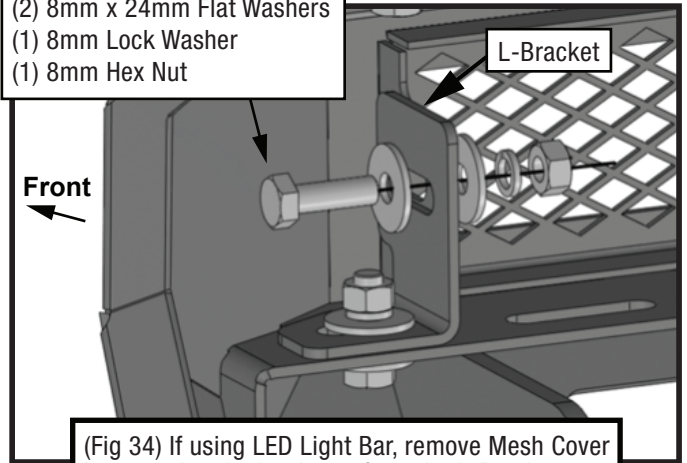

- (1) 8mm x 16mm Hex Bolt
- (1) 8mm x 24mm Flat Washer
- (1) 8mm Lock Washer

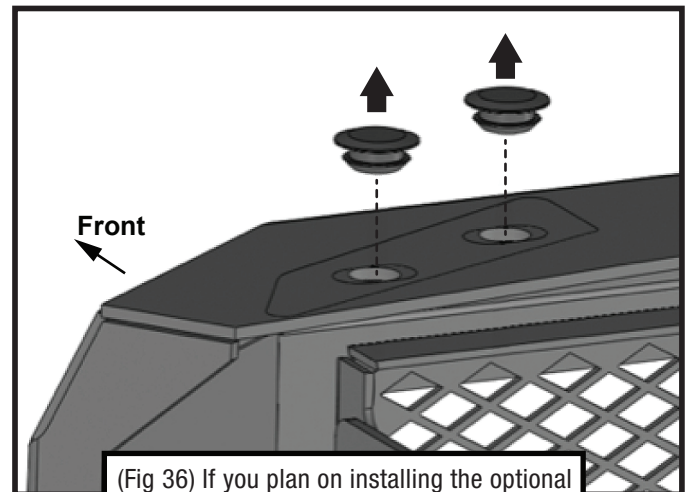
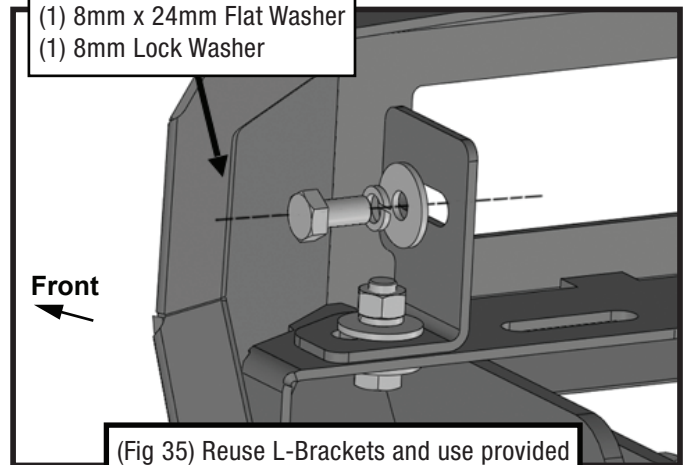

## STEP 5 INSTALLING FRONT BUMPER

Follow (Figs 34 – 43) to install Center Bumper Guard.

- (2) 8mm x 25mm Button Head Bolts
- (4) 8mm x 24mm Flat Washers
- (2) 8mm Lock Washers
- (2) 8mm Hex Nuts

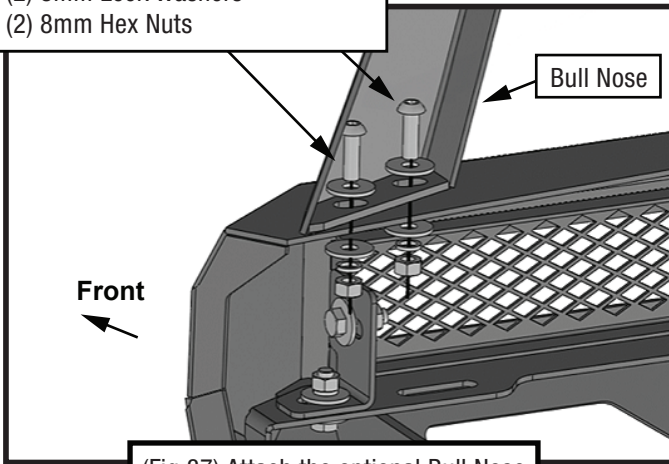

(Fig 37) Attach the optional Bull Nose to Center Bumper Guard

- (3) 12mm x 40mm Hex Bolts
- (3) 12mm x 24mm x 3mm Flat Washers
- (3) 12mm Lock Washers

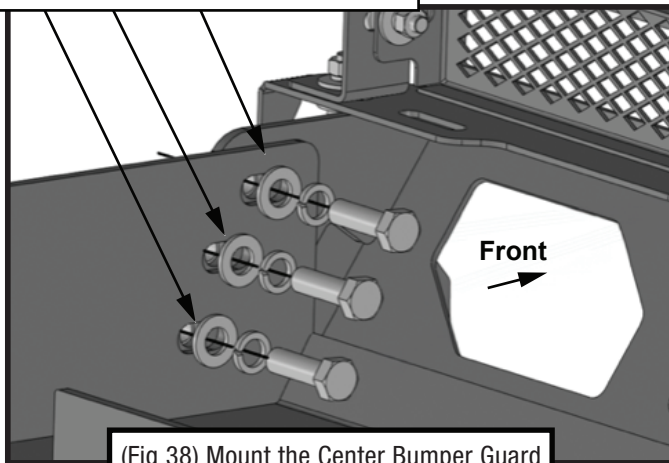

(Fig 38) Mount the Center Bumper Guard to Winch Tray on both sides



(Fig 39) Center Bumper Guard mounted

(Fig 40) Attach Skid Plate to Center Bumper Guard and Threaded Inserts on the vehicle

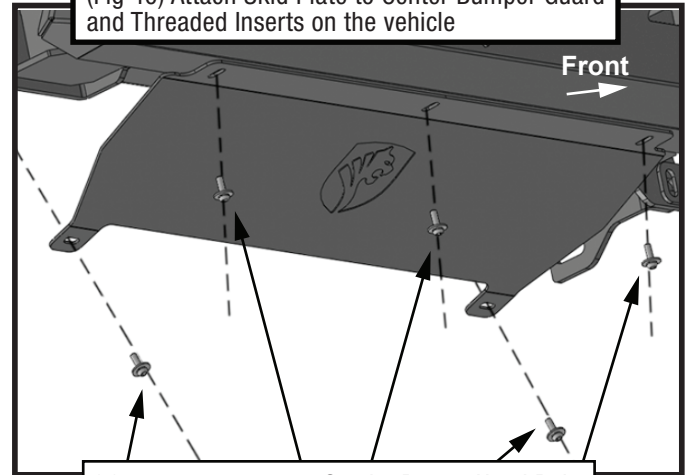

(5) 6-1.0mm x 20mm Combo Button Head Bolts

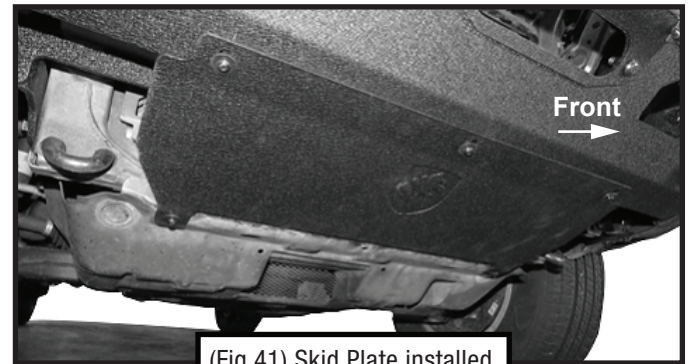

(Fig 41) Skid Plate installed

- (2) 10mm x 30mm Button Head Bolts
- (4) 10mm x 20mm x 2mm Flat Washers
- (2) 10mm Nylon Lock Nuts

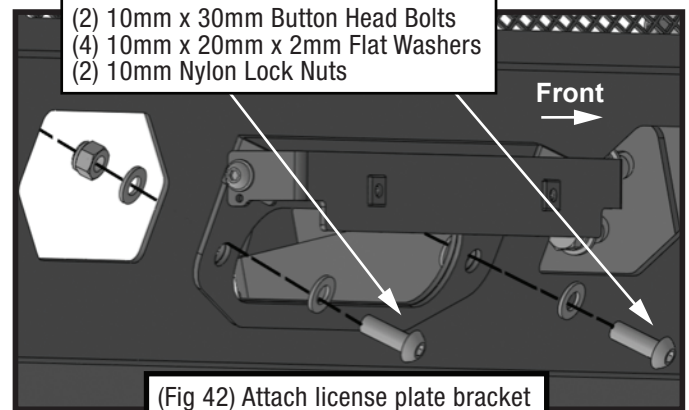

(Fig 42) Attach license plate bracket onto Center Bumper Guard

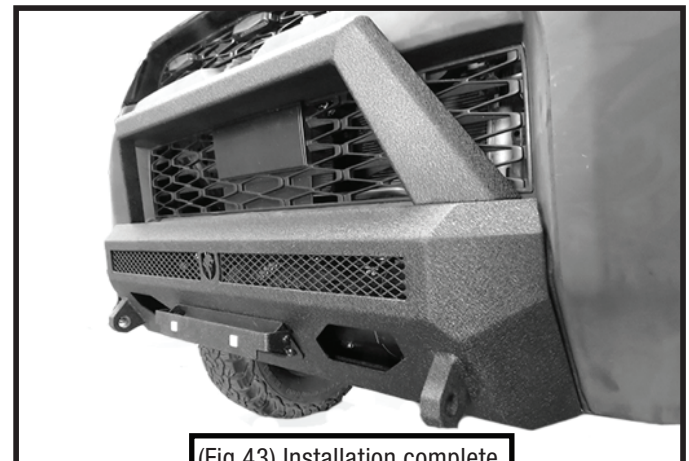

(Fig 43) Installation complete