



# TYGER®

## FENDER FLARE

TG-FF6F5008



### ATTENTION!

PLEASE READ THE INSTRUCTIONS CAREFULLY BEFORE STARTING INSTALLATION. FOLLOW EACH STEP AS DESCRIBED ON THIS OFFICIAL GUIDE. FAILURE TO DO SO MAY CAUSE DAMAGE TO YOUR VEHICLE AND VOID THE WARRANTY.



### WARNING!

DIRT OR DEBRIS MAY BECOME LODGED BETWEEN FLARES AND BODY PANEL CAUSING SCRATCHING AND PAINT-WEAR AS A RESULT OF VEHICLE VIBRATION. TYGER™ IS NOT RESPONSIBLE FOR SUCH DAMAGE, AND INSTALLATION IS DONE WITH BUYER'S UNDERSTANDING THAT THIS DAMAGE MAY OCCUR.

#### PRIOR TO INSTALLATION:



CHECK EVERYTHING BEFORE INSTALLATION



USE NON-ABRASIVE SURFACE TO INSTALL



VERIFY FITMENT OF FLARES TO VEHICLE



REMOVE DECALS & MUD FLAPS FIRST



ABRASIVE DETERGENT IS PROHIBITED

#### SAFETY INFORMATION:



NO AUTOMATIC BRUSH-STYLE WASH



CHECK TIGHTNESS



CHECK CAREFULLY BEFORE DRIVE

**ABOUT PAINTING:** Painted flares cannot be returned. Test fit before painting. We are not responsible for any costs that may incur if flares were painted without test fitting.

- Clean surface to be painted with a good grade degreaser. Do not use lacquer thinner or any solvent based product.
- Wipe flare surface completely dry with a tack rag prior to paint.
- Application of plastic adhesion promoter for PP plastic as per your paint system manufacturer's recommendations is required.
- Use a high quality enamel or polyurethane automotive paint to paint the flares.
- Not recommend to paint the edge trim, but if desired use a flex additive.

### Parts List:



Driver/Left Side Front Flare

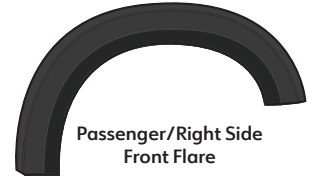

Passenger/Right Side Front Flare



Driver/Left Side Rear Flare



Passenger/Right Side Rear Flare



Inner Bracket

NOTE: Both inner brackets are identical



[A] Edge Trim

x8



[B] 5/8" PH Truss Screw

x6



[C] 5/16" PH Truss Screw

x2



[D] Long U Clip

x6



[E] S-Clip

x6



[F] Mylar Tab

x4



[G] Nylon Retainer

x1



[H] Edge Trim Tool

#### Tools For Easier Installation

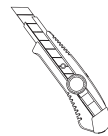

Utility Knife

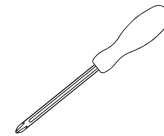

#2 Phillips Driver



1/2" Wrench

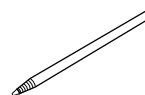

Grease Pencil



Work Gloves

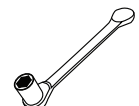

Socket Wrench

DAMAGED or MISSING parts?

[www.tygerauto.com/contact](http://www.tygerauto.com/contact)



# Edge Trim Installation

Peel 2 to 3" of red vinyl backing off from one end of the **Edge Trim [A]**.

- Apply **Edge Trim [A]** over top edge of flare with adhesive side attached to the inside edge of flare.
- Press **Edge Trim [A]** into place and apply thumb pressure to ensure good adhesion, continue to peel off red backing as you work your way along flare edge in one-foot increments.

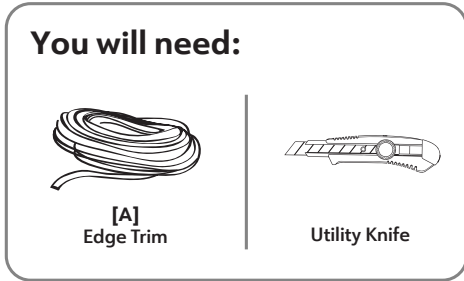

**⚠ Note!**

DO NOT stretch Edge Trim during application.

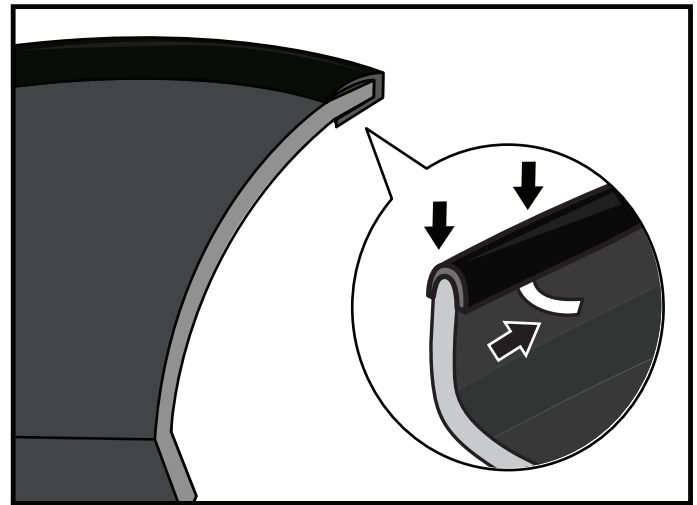

# Front Flares Installation (Passenger Side shown)



**NOTE!**

Only use appropriate cleaning supplies for your vehicle. If needed, clean and dry off before you begin installing.



**ATTENTION!**

Work gloves are recommended for protection against possible sharp objects during installation.

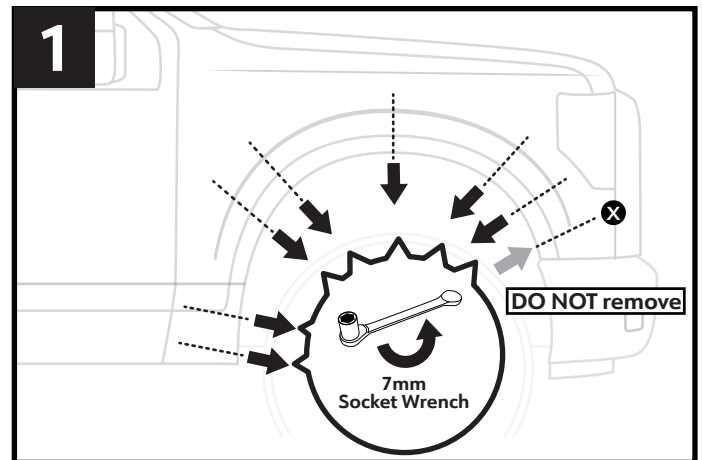
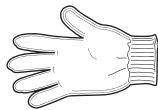

1. With 7mm socket wrench, remove and keep 7 factory screws to be reinstalled later. Note: DO NOT remove the 8th screw as shown.

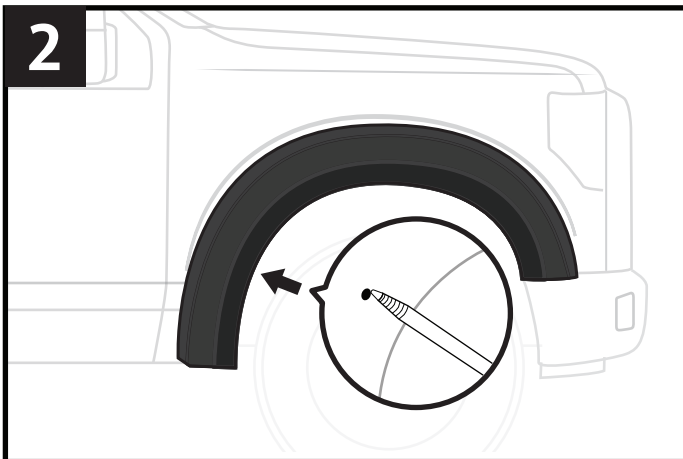

2. Hold up Passenger Front Flare and with a grease pencil, mark location through the 3rd hole from the bottom of the fender flare.

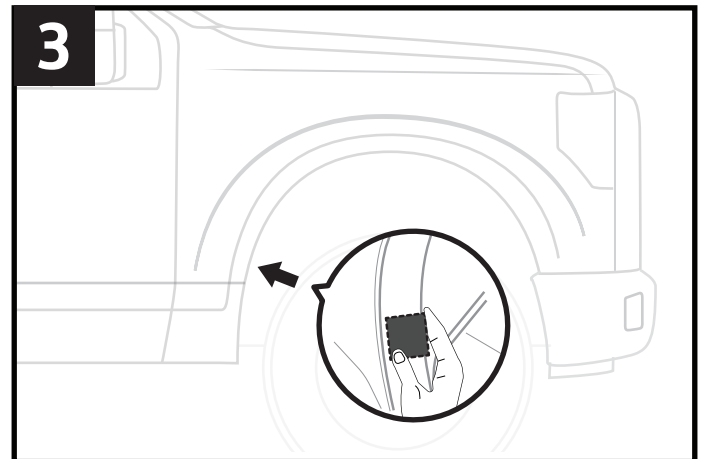

3. Take a **Mylar Tab [J]** and wrap it around the metal sheet and over the marked hole position from **STEP 2**.

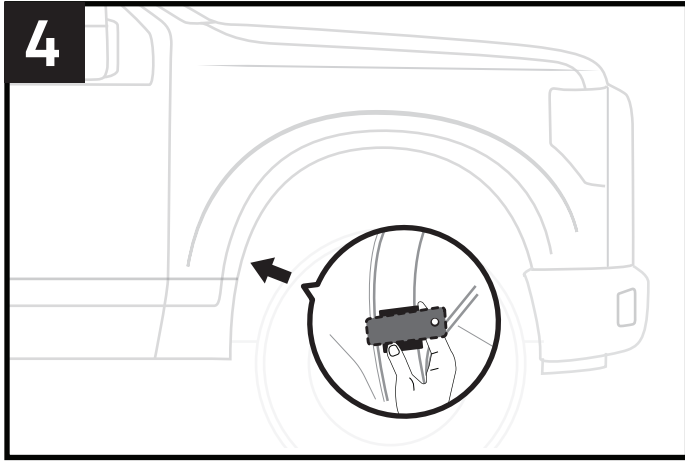

4. Apply an **U-Clip [D]** over the Mylar Tab.

**3 CLIPPED HOLES PER SIDE**

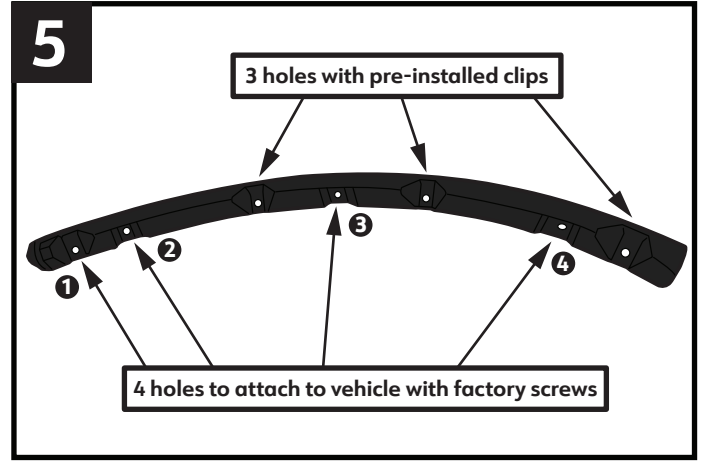

5. Before we begin inner bracket installation, first review this diagram for break-down of holes.

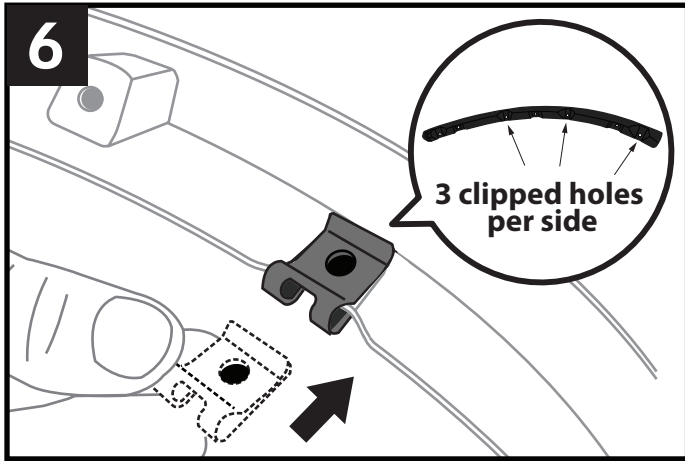

6. Next, make sure there are 3 short clips pre-installed. Note: Inner brackets improve access to the holes to which the Fender Flares will be attached.

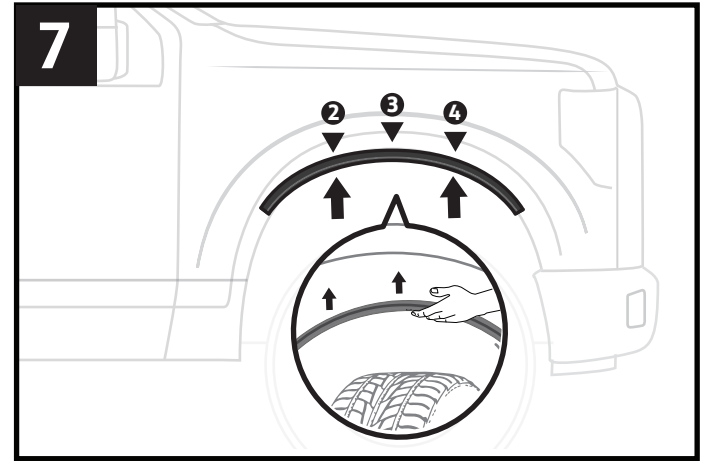

7. Now, take inner bracket and align holes 2,3,4 (indicated in STEP 5) with the top 3 factory holes exposed from STEP 1.

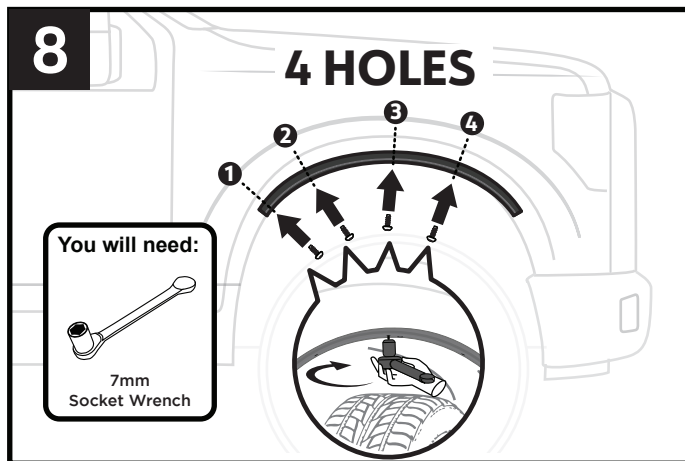

8. With a 7mm socket wrench, reinstall 4 factory screws removed from STEP 1 through flare holes 1,2,3,4 and into the factory holes.

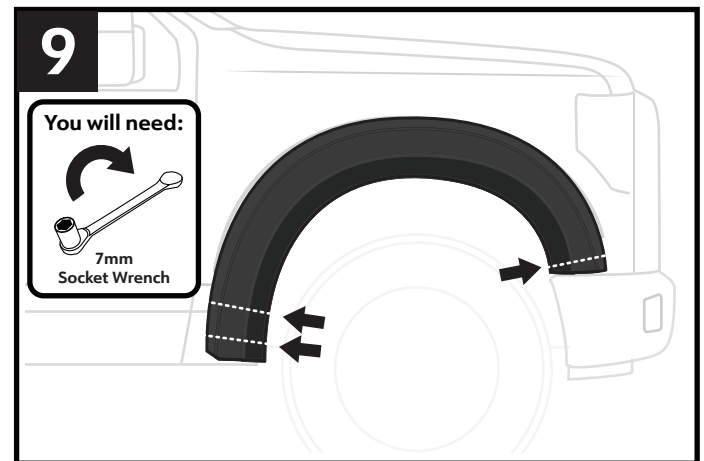

9. Position Passenger Front Flare to the fender and reinstall the 3 remaining factory screws to the indicated locations.

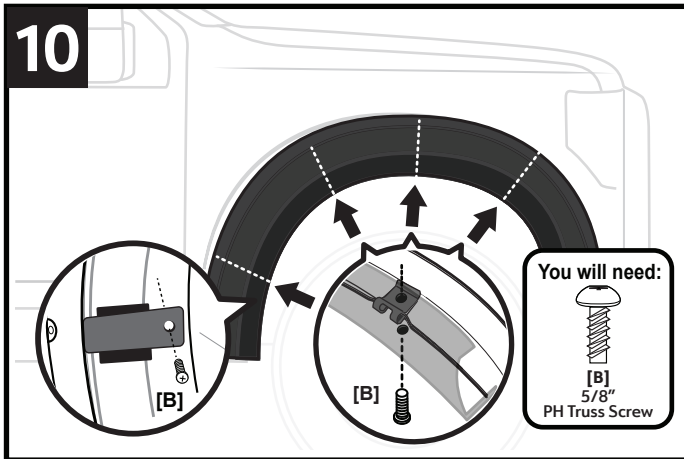

10. Press flare inward and firmly against the body panel and install 4 x 5/8" Truss Screws [B] through the flare and into the clip installed in STEP 4 and the 3 clipped holes on the inner bracket shown in STEP 5.



11. Tighten all screws. Repeat STEPS 1 to 10 to install the driver side front flare.

## Rear Flares Installation (Passenger Side shown)

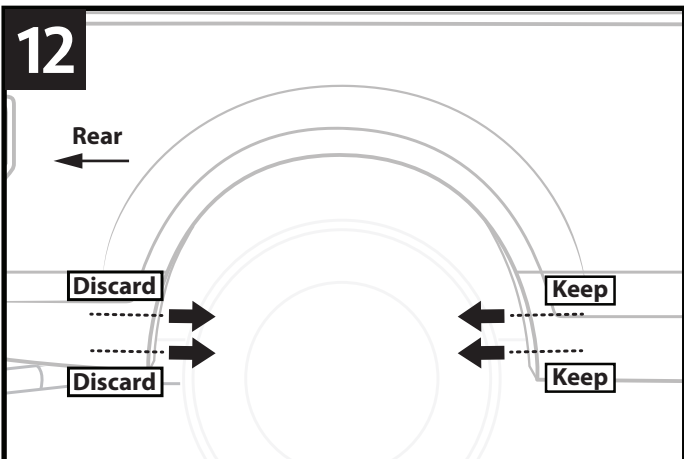

12. Remove 4 factory fasteners from the indicated locations. Keep the 2 front side 7mm screws and discard the 2 rear side fasteners.

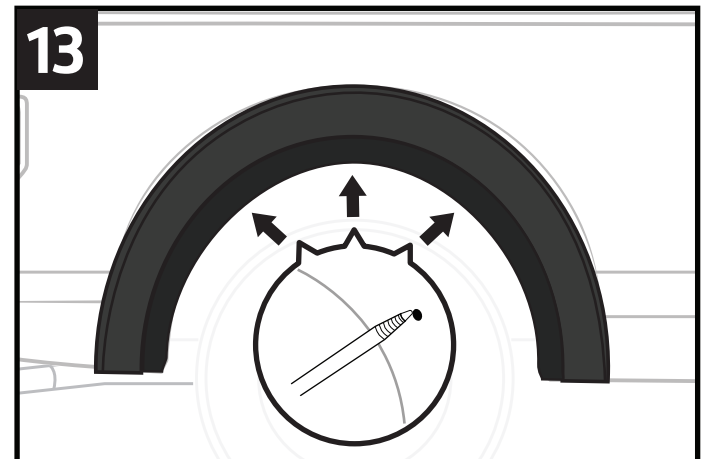

13. Hold up Passenger Rear Flare and with a grease pencil, mark the 3 top hole locations through the flare as shown.

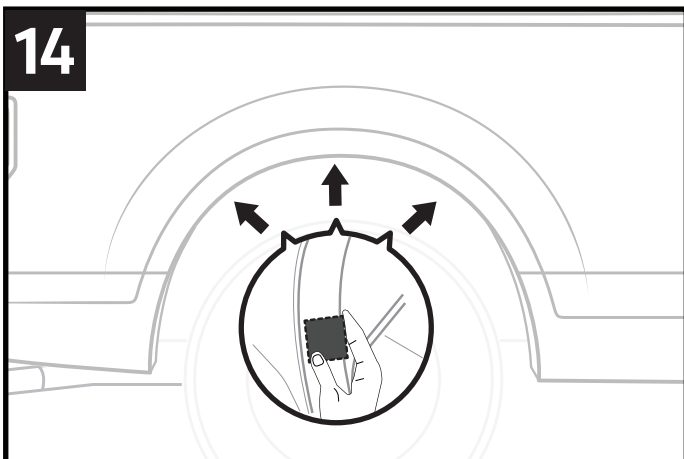

14. Wrap a Mylar Tab [F] over each of the 3 marked locations and around the metal sheet.

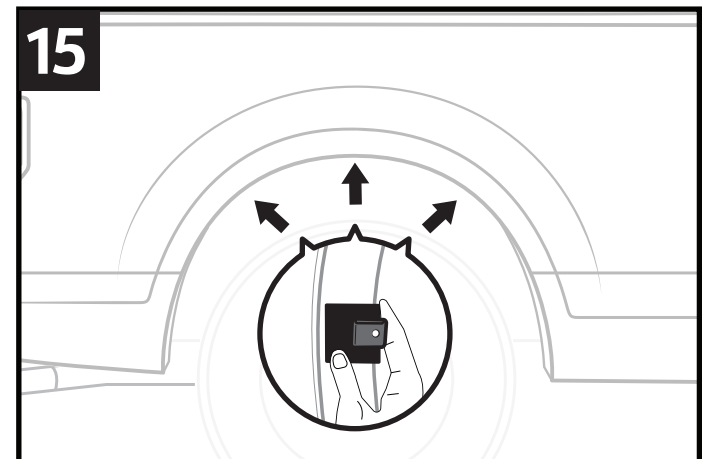

15. Install a S-Clip [E] over each Mylar Tab location as shown.

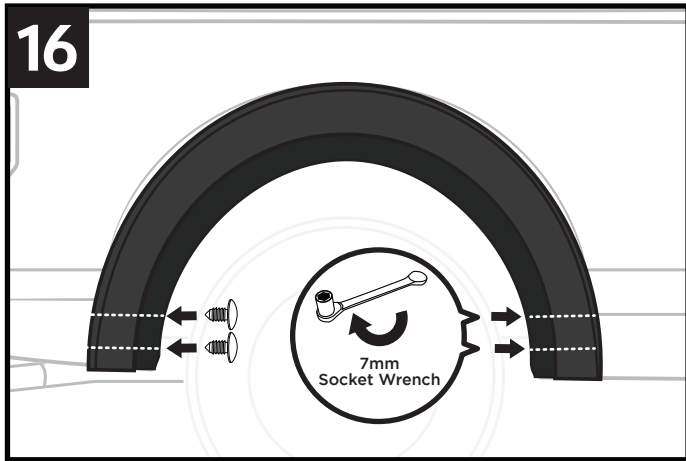

16. Hold up flare again firmly press against the vehicle. Then reinstall the 2 front screws removed from STEP 12 with 7mm socket wrench. Apply 2 Nylon Retainers [G] to the 2 rear bottom holes.

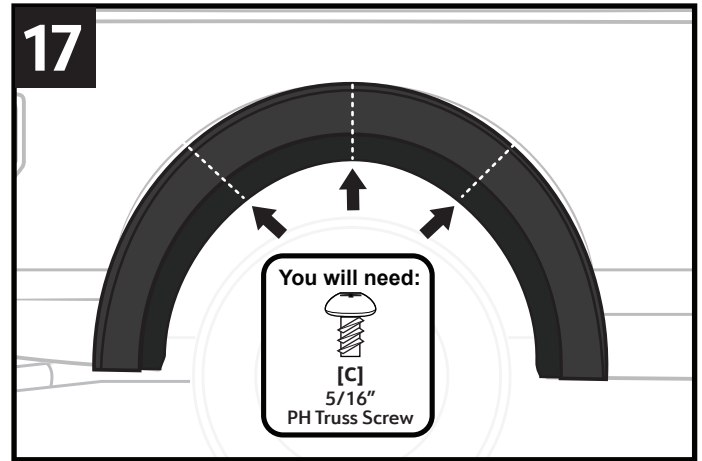

17. While applying pressure to the flare, install a 5/16" Truss Screw [C] through the 3 top flare holes and attach to the S-Clips.



18. Tighten all screws. Repeat STEPS 12 to 17 to install the driver side rear flare.

## Edge Trim Tool Usage (Optional):

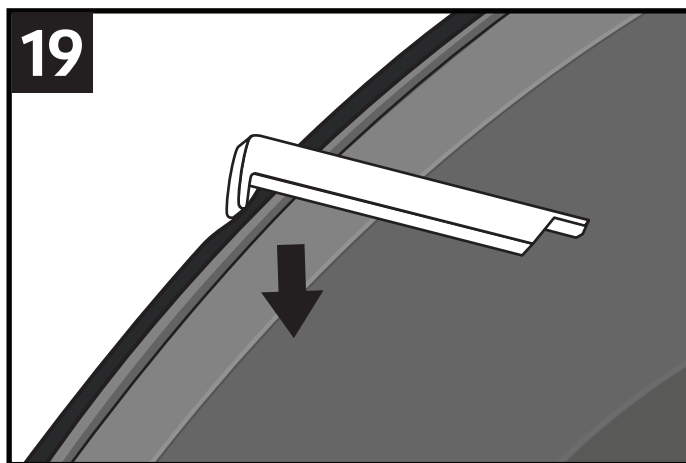

19. If needed, use supplied Edge Trim Tool [H] to trim outer edge by inserting the curved end, then sliding around the entire trim from one end to the other.

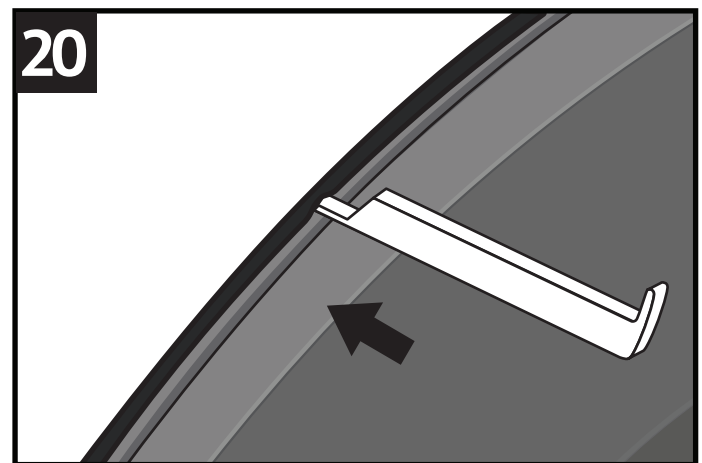

20. If needed, use supplied Edge Trim Tool [H] to trim inner edge by inserting the straight end, then sliding around the entire trim from one end to the other.

## Final Result:

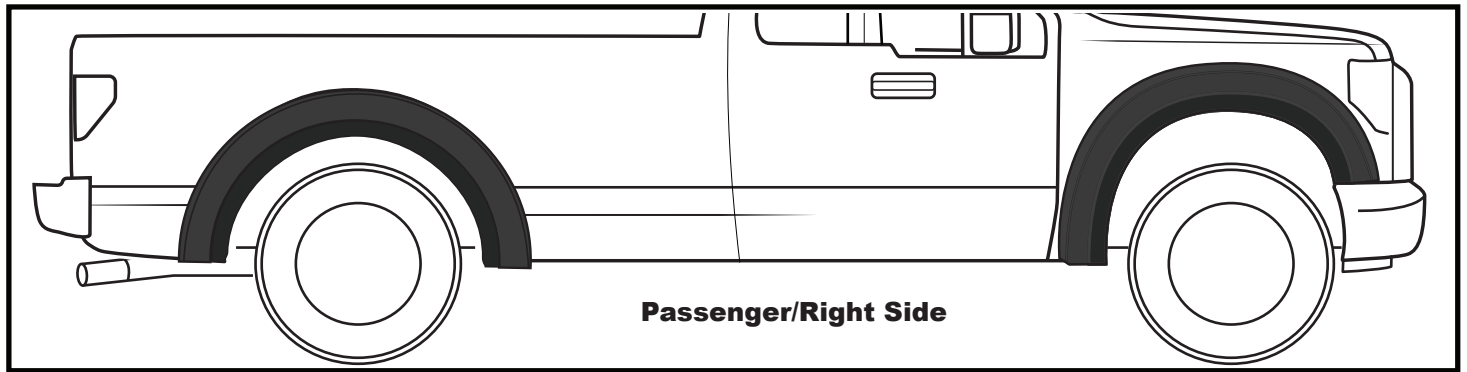

Note: Above image is for reference ONLY, final result may vary.

## Fitment or Gap Issue?

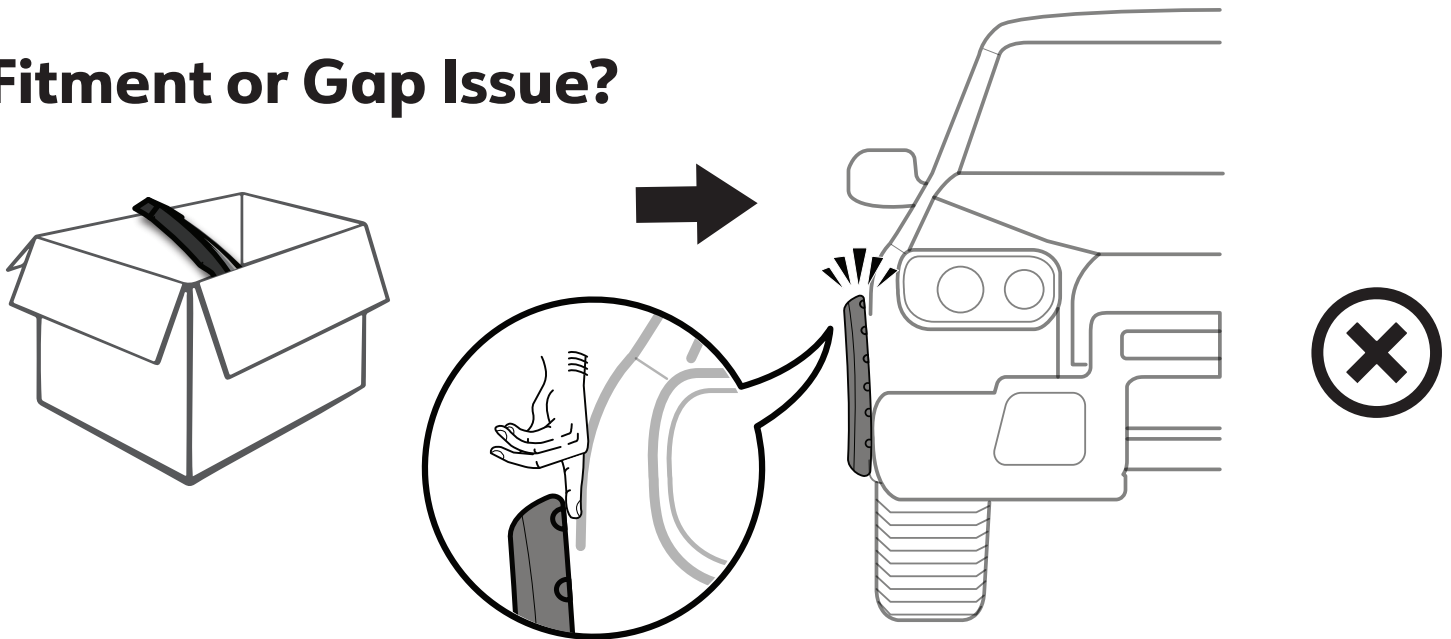

## Solution!

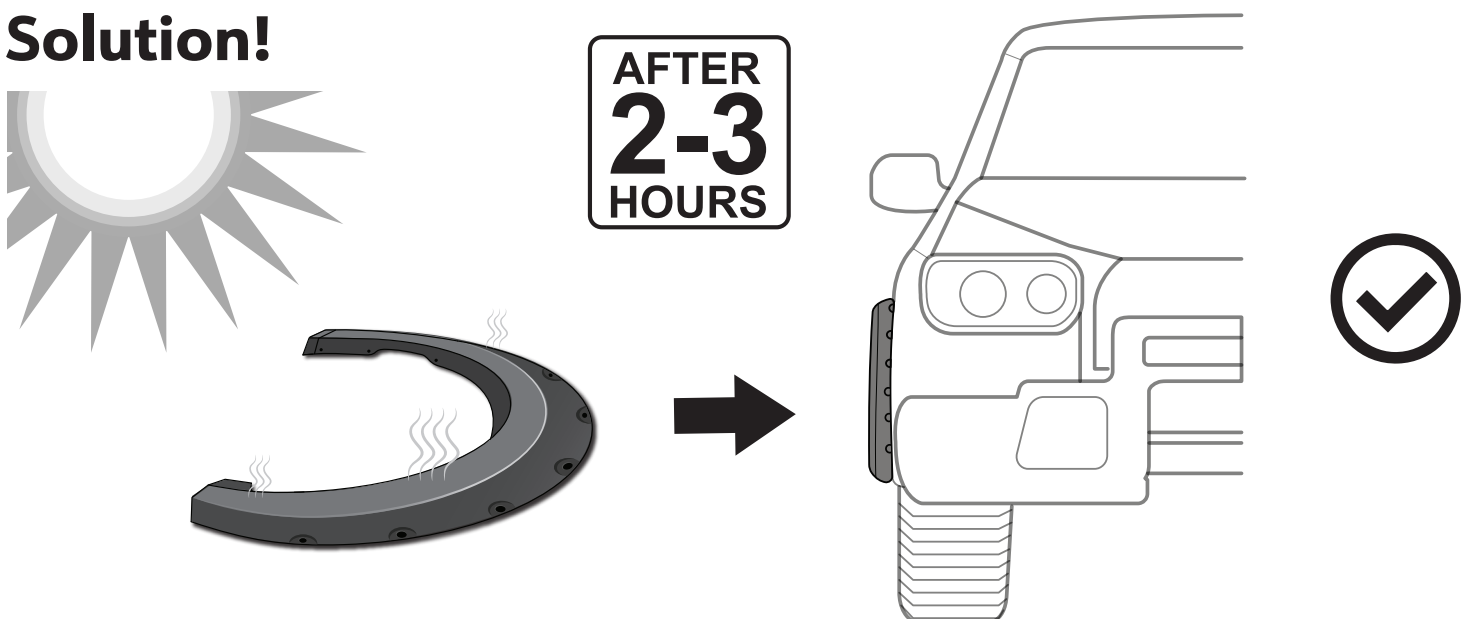

\*In winter, heat gun or hair dryer may be used instead.