



FENDER FLARE

TG-FF8D4147

PLEASE READ AND FOLLOW THIS APPROVED INSTRUCTION CAREFULLY BEFORE INSTALLATION. FAILURE TO DO SO MAY CAUSE DAMAGE TO THE VEHICLE AND WILL INVALIDATE THE WARRANTY.

PRIOR TO INSTALLATION

- Remove contents from box. Verify all parts are present and free from any defects or damage.
- Make sure installation is done on a non-abrasive surface to avoid scratching the flare surface.
- Pre-fit each flare to the vehicle body to ensure they suit the profile of the vehicle.
- Remove existing decals and mud flaps on the vehicle that may interfere with flare installation.
- Make sure all flares and fender wheel well are clean as the presence of dirt or sand may scratch auto body paint.
- Suggest removing the tire before installation for easier access.
- Do not use any harsh abrasive detergent to clean the flare.

PAINTING

Painted flares cannot be returned. Test fit before painting. We are not responsible for any costs that may incur if flares were painted without test fitting.

- Clean surface to be painted with a good grade degreaser. Do not use lacquer thinner or any solvent based product.
- Wipe flare surface completely dry with a tack rag prior to paint.
- Application of plastic adhesion promoter for PP plastic as per your paint system manufacturer's recommendations is required.
- Use a high quality enamel or polyurethane automotive paint to paint the flares.
- Not recommend to paint the edge trim, but if desired use a flex additive.

WARNING

Dirt or debris may become lodged between flares and vehicle's fenders causing scratching and paint wear from vehicle vibration. TYGER is not responsible for any damage, and installation is done with buyer's understanding that this damage may potentially occur.

SAFETY INFORMATION

- Before driving, ensure that flare is properly secured to vehicle.
- Do not use automatic "brush-style" car wash.
- Periodically check all components for tightness.

Tools Required



Socket Wrench



8mm Socket



#2 PH Driver



1/2" Wrench



Utility Knife



Awl Tool

Hardware Included



[A]



[B]



[C]



[D]



[E]



[F]



[G]



[H]



[I]

DAMAGED or MISSING PARTS?

www.TygerAuto.com/Contact



EDGE TRIM INSTALLATION

- Peel 2 inches of red backing away from one end of Edge Trim **[A]** .
- Apply Edge Trim over top edge of flare with adhesive side contacting inside edge of flare.
- Press Edge Trim into place and apply thumb pressure to ensure good adhesion, pull away red backing as you work your way around flare edge in one-foot increments. (Fig 1)

A. Cut out a "V" on the Edge Trim when installing over outward edges in the flare.

B. Make a straight cut on the Edge Trim when installing over inward curve in the flare.

NOTE: Do not stretch Edge Trim during application.

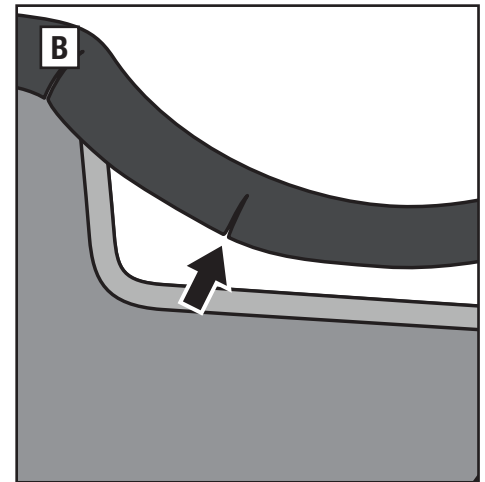
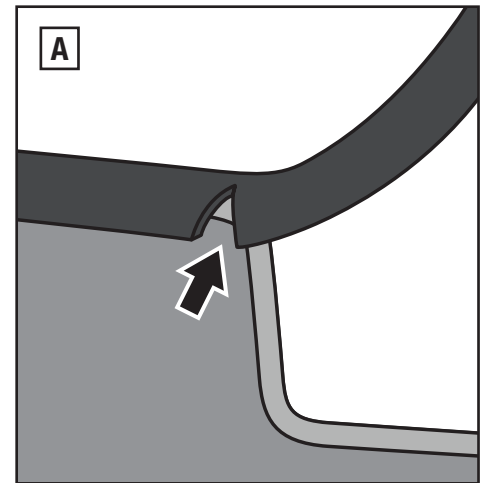
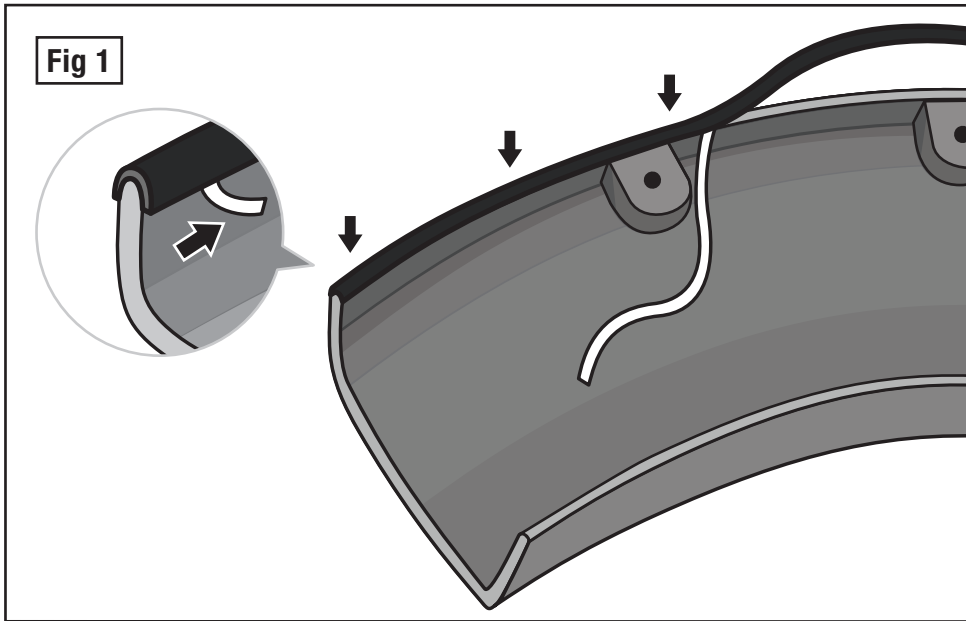

DECORATIVE RIVET INSTALLATION

- Install Torx Bolt **[B]** with Washer **[C]** through each of the top holes around the flare and secure by using Nylock Nut **[D]** on the other side (Fig 2). Tighten by using socket wrenches and the supplied Torx Bit **[E]**. Do not over-tighten as this may damage the flare.

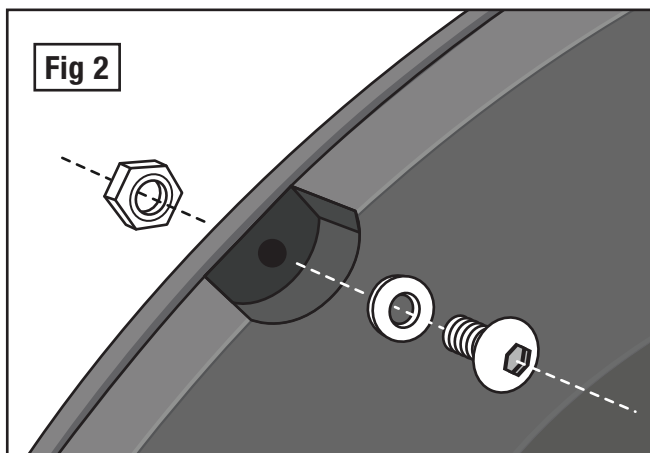

IMPORTANT: Do not drill holes to the vehicle body as rivets are decorative and fasten only to the flare. Do not attempt to use the bolts to fasten flare to vehicle body.

EXTRA NOTES

- Prior to installation, please use rust-resistant paint or rust primer on exposed metals to prevent rusting. Spray inner fender wells with undercoating after flare installation.

- Some modifications may be needed to maintain a minimum of 4" clearance between flares and exhaust pipes to avoid exhaust gases discharge directly onto fender flares.

- For vehicle with large tires, care must be taken to ensure tires do not make contact with flares.

Front Passanger Side Installation

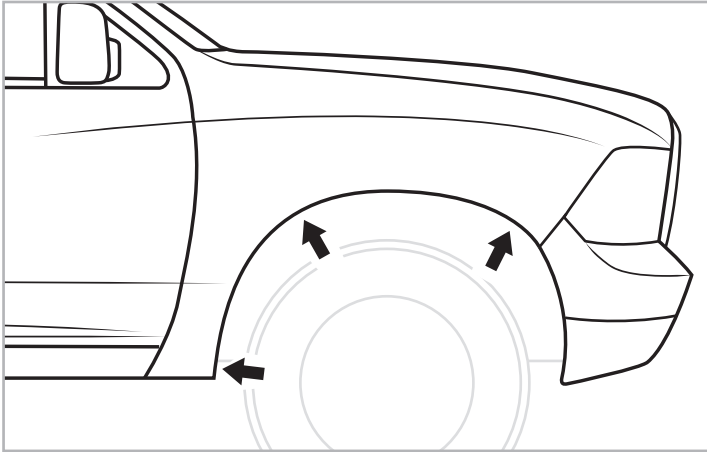

STEP 1: With an 8 mm socket wrench, remove 3 factory screws.

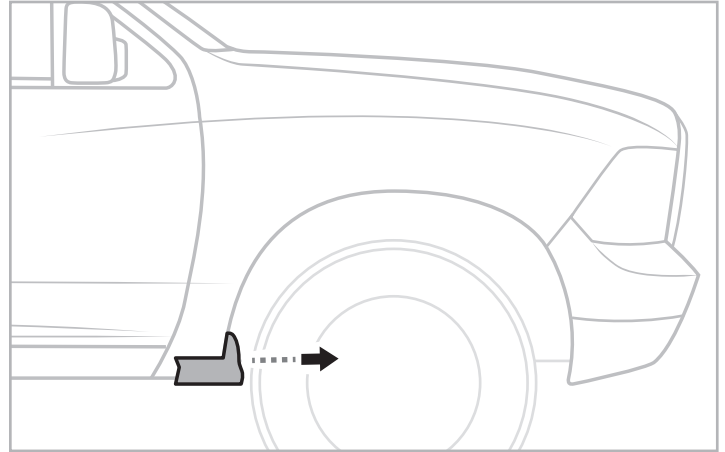

STEP 2: (For 2011-2012 Models)

Remove inner guard at bottom rear of fender well using 8 mm socket.

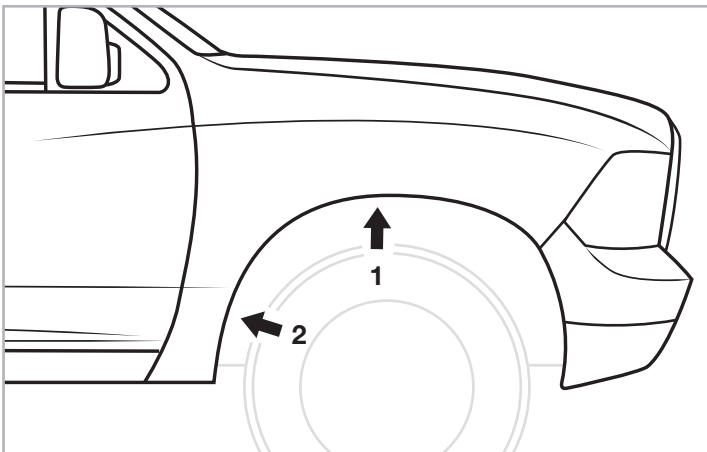

STEP 3: Locations to install the Tab [F] and the U-clip [G]. Refer to Step 4-5 for more details.

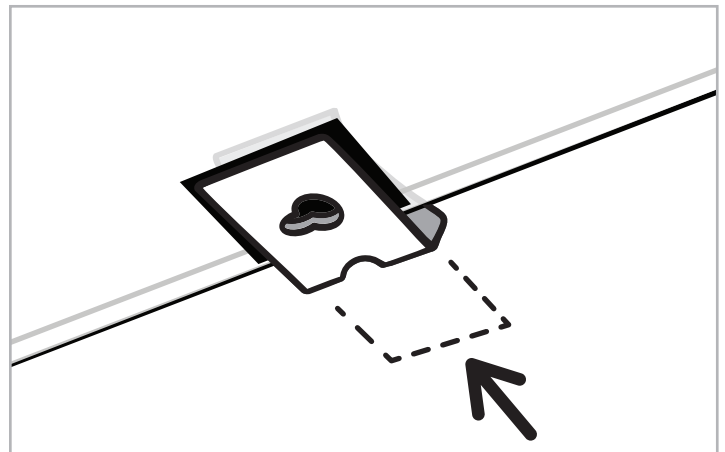

STEP 4: Stick the supplied Tab [F] over factory holes as shown. Then, slide a supplied U-clip [G] over each Tab.

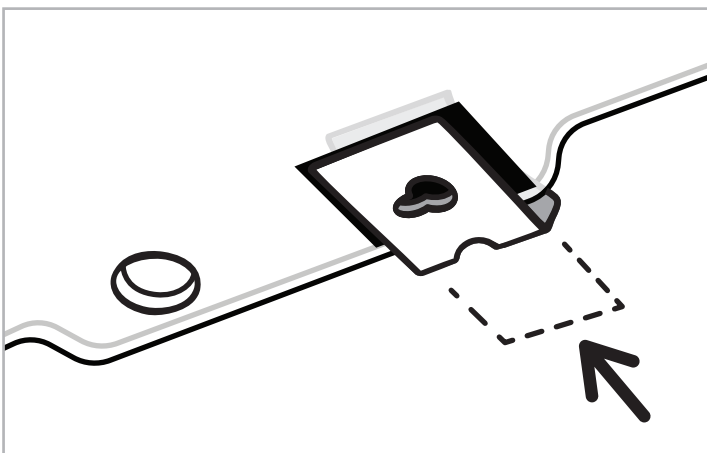

STEP 5: For location 2 marked in Step 3, stick the Tab [F] over the hole located more towards the front of the vehicle.

NOTE: U-clips can be pinched to fit tighter over the fender lip.

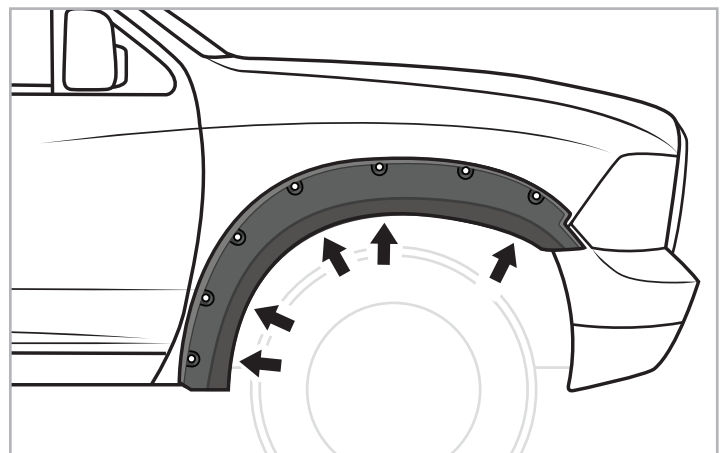

STEP 6: Position flare; with a Phillips Screwdriver, install 5 supplied PH Truss Screws [H] without tightening fully. Then, press flare firmly against the fender and tighten all screws.

Rear Passanger Side Installation

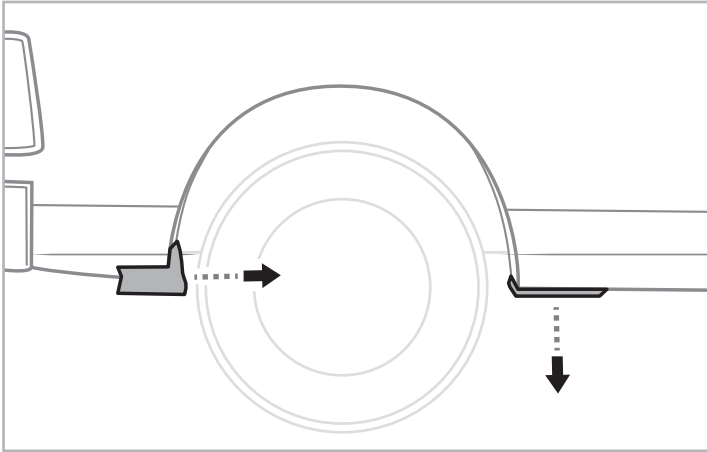

STEP 7: (For 2011-2012 Models)

Remove the inner guard pieces at bottom front and rear of the fender wheel well. Use a pry tool for the front piece.

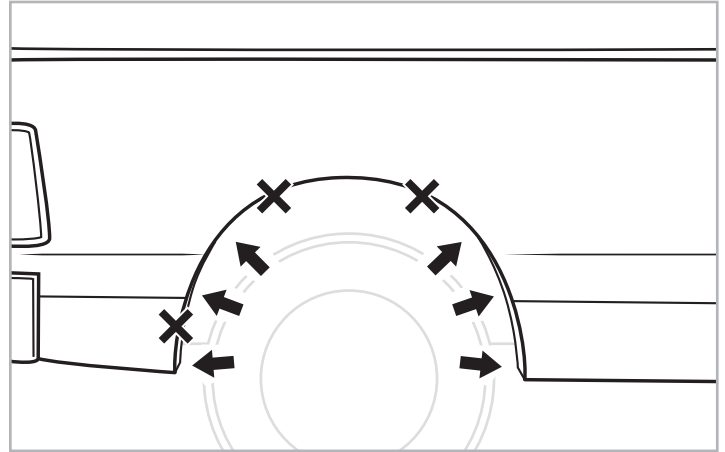

STEP 8: With an 8 mm socket wrench, remove 6 factory screws at the locations indicated by the arrows.

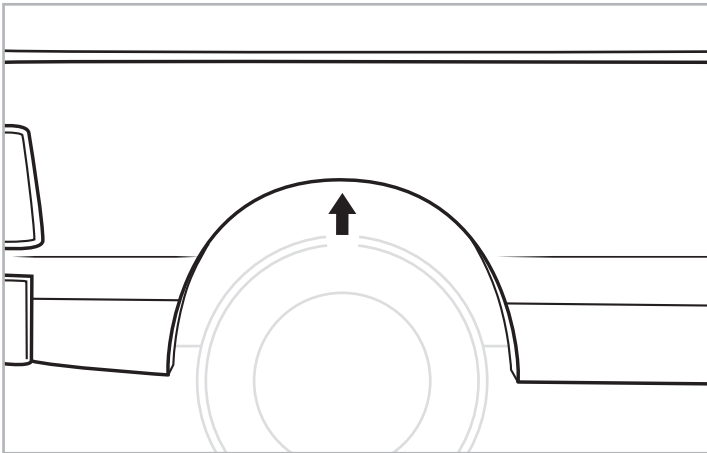

STEP 9: Install a supplied Tab [F] and a supplied U-clip [G] at the top location. Refer to Step 10-11 for more detail.

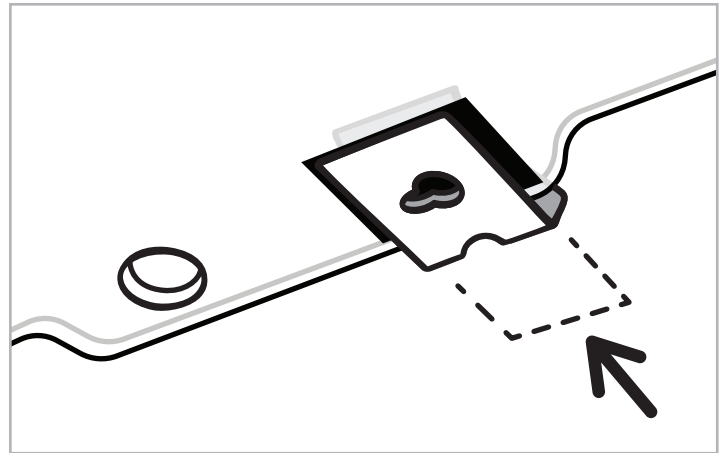

STEP 10: Stick a supplied Tab [F] over the factory hole and slide a supplied U-clip [G] over the Tab as shown.

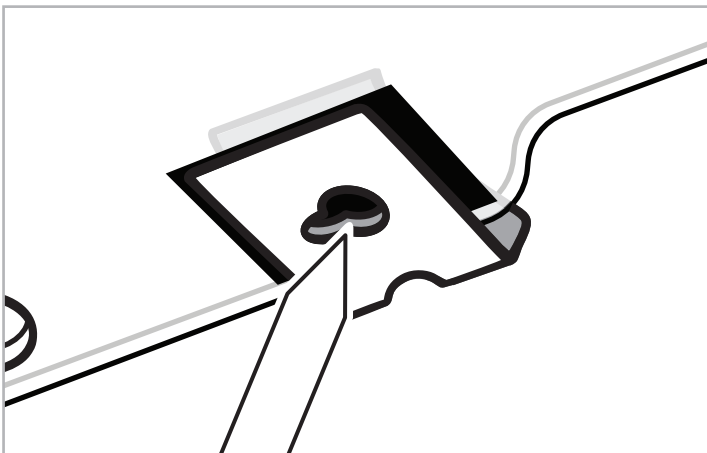

STEP 11: With an awl, poke a hole in the Tab through the U-clip.

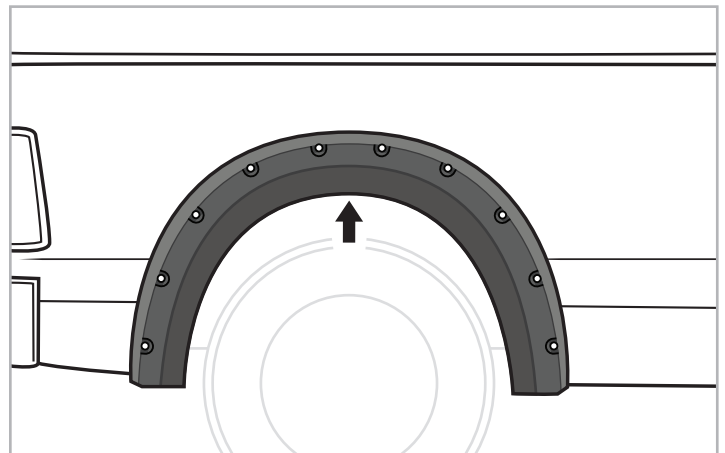

STEP 12: Position flare to vehicle. Install a supplied PH Truss Screw [H] through the flare and into the U-clip. Do not tighten.

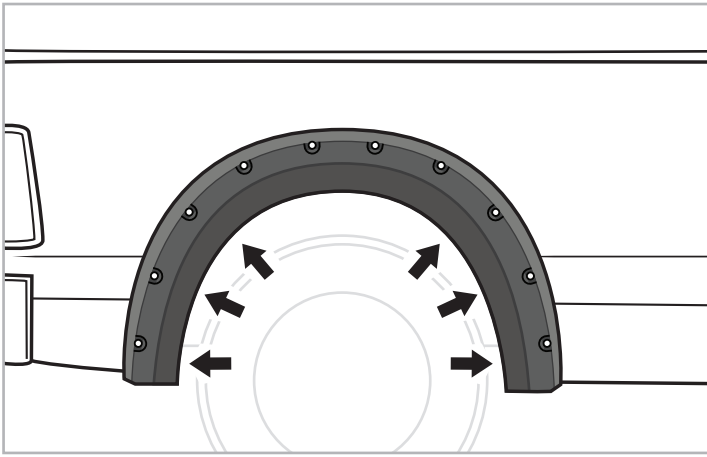

STEP 13: Install 6 supplied PH Truss Screws [H] without tightening fully.

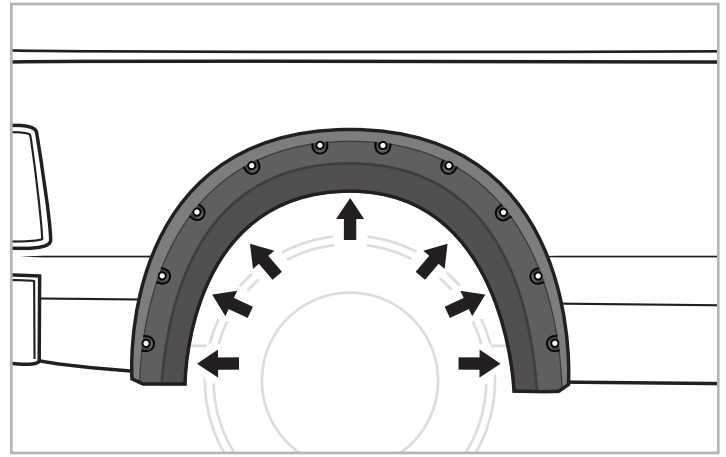

STEP 14: Press flare firmly in place and tighten all screws.

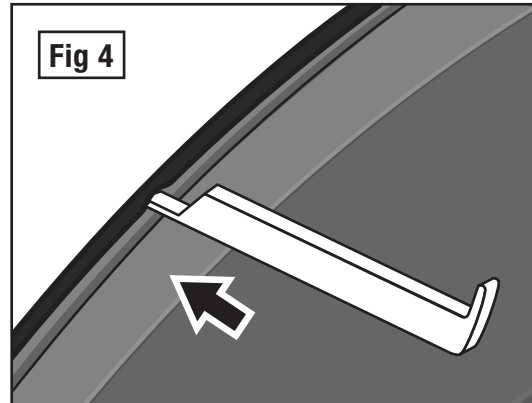
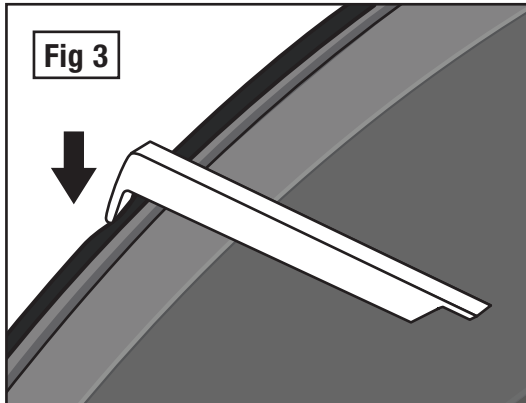

STEP 15: If needed use supplied tool [I] to trim outer edge (Fig 3) and inner edge (Fig 4) by inserting tool ends then sliding around the entire edge trims from one end to the other as shown in above pictures.

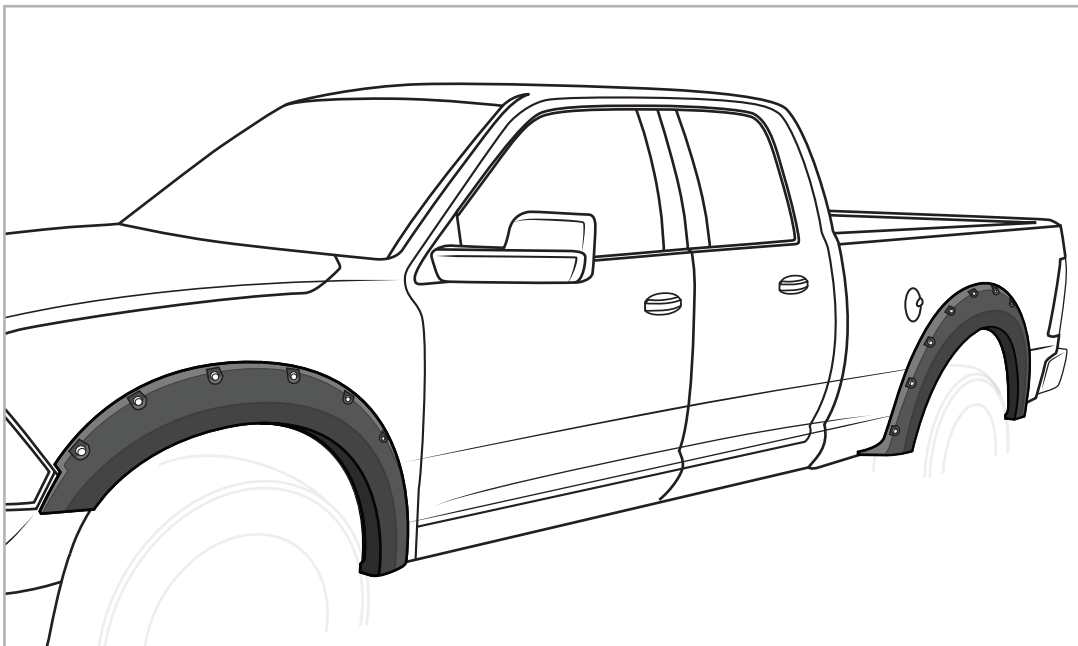

Passanger side installation is completed. (Repeat the same steps on driver side installation)

FITMENT OR GAP ISSUE?

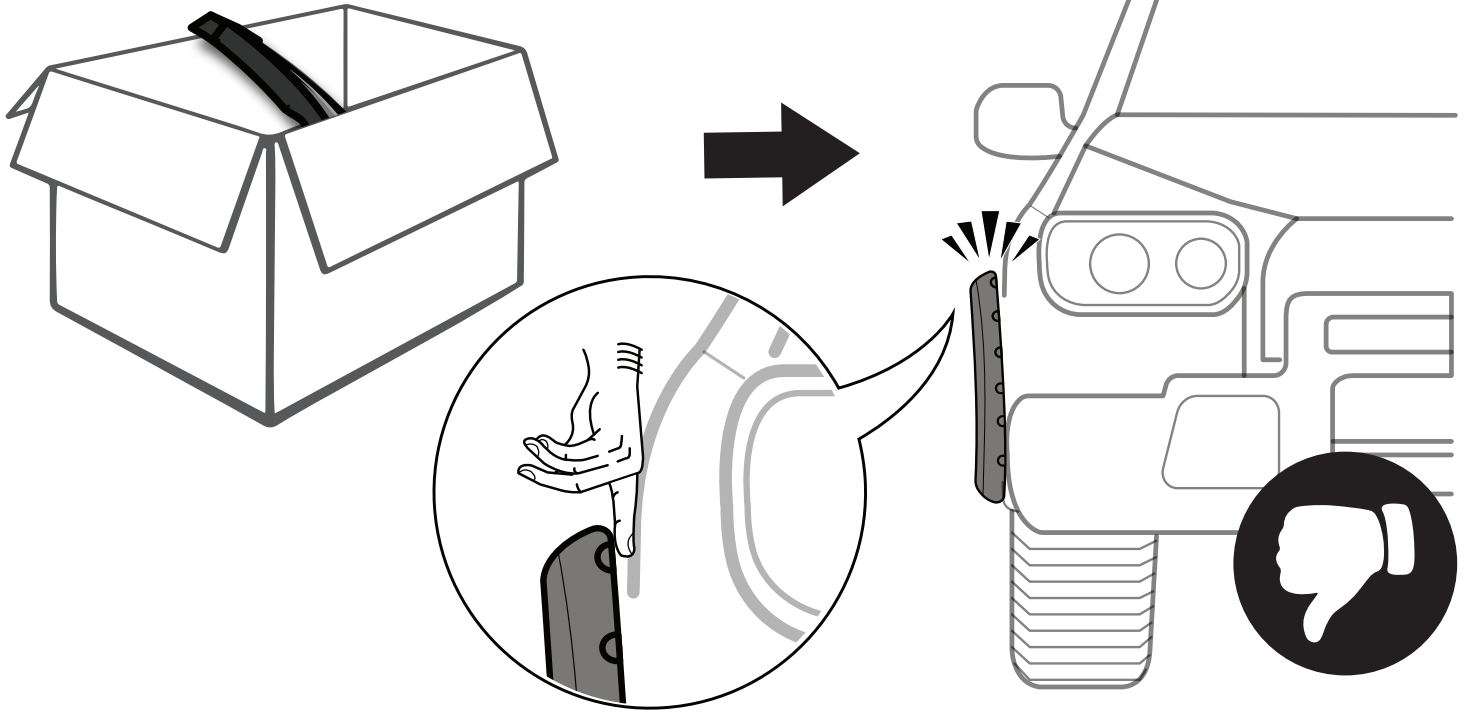

SOLUTION!

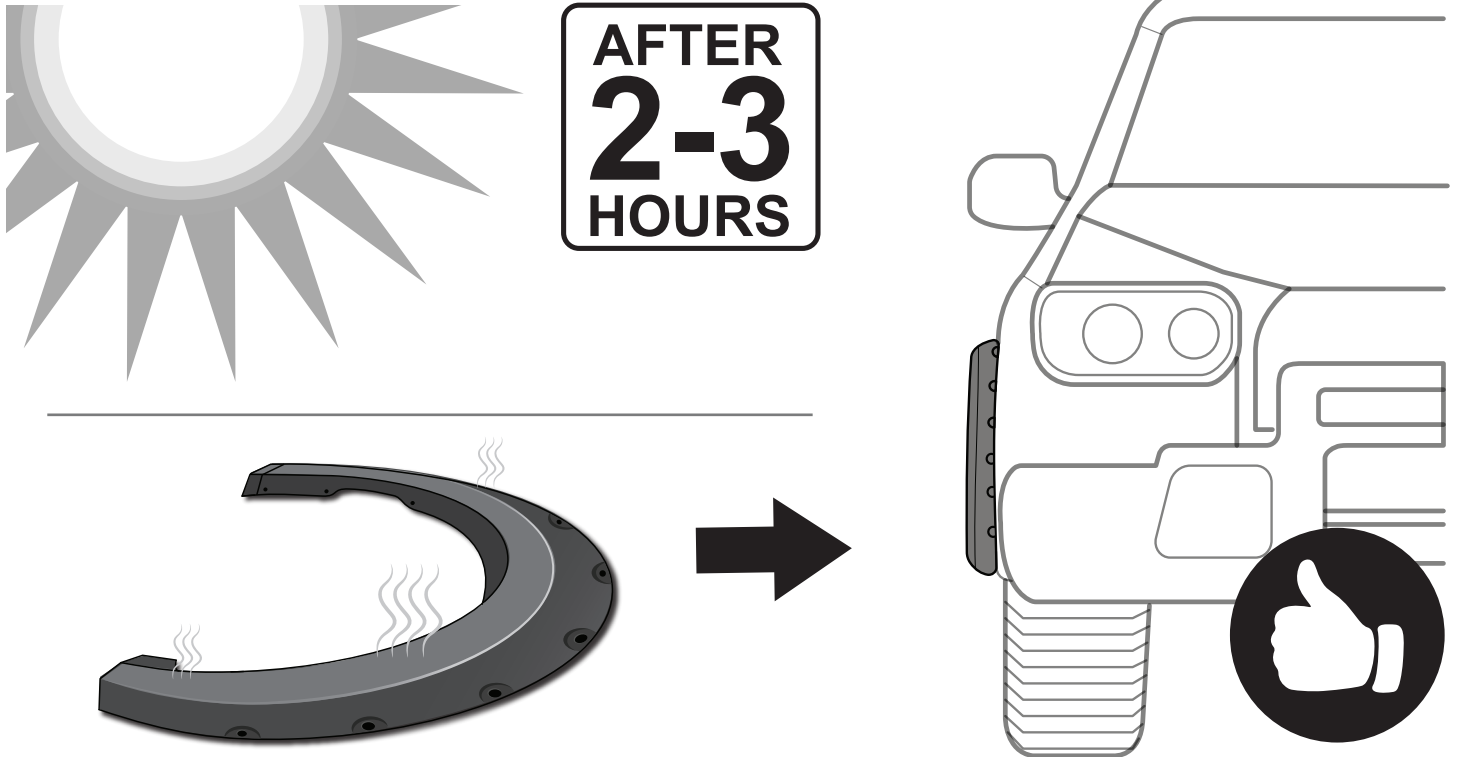

*In winter, heat gun or hair dryer may be used instead.