



# TYGER®

## FENDER FLARE

TG-FF8D4478



### ATTENTION!

PLEASE READ THE INSTRUCTIONS CAREFULLY BEFORE STARTING INSTALLATION. PLEASE FOLLOW THE APPROVED INSTALLATION ACCORDING TO THE WRITTEN INSTRUCTIONS. FAILURE TO DO SO MAY CAUSE DAMAGE TO YOUR VEHICLE AND INVALIDATE THE WARRANTY.



### WARNING!

PARTICLES & DIRT STUCK BETWEEN INSTALLED FLARES AND VEHICLE'S FENDERS MAY CAUSE SCRATCHING AND PAINT WEAR FROM VEHICLE VIBRATION. INSTALLATION IS DONE WITH BUYER'S AND/OR USER'S UNDERSTANDING THAT THIS DAMAGE MAY POTENTIALLY OCCUR. TYGER™ IS NOT RESPONSIBLE FOR ANY DAMAGE FROM THIS CAUSE.

#### PRIOR TO INSTALLATION:



CHECK EVERYTHING BEFORE INSTALLATION



USE NON-ABRASIVE SURFACE TO INSTALL



VERIFY FITMENT OF FLARES TO VEHICLE



REMOVE DECALS & MUD FLAPS FIRST



ABRASIVE DETERGENT IS PROHIBITED

#### SAFETY INFORMATION:



NO AUTOMATIC BRUSH-STYLE WASH



CHECK TIGHTNESS



CHECK CAREFULLY BEFORE DRIVE

**ABOUT PAINTING:** Painted flares cannot be returned. Test fit before painting. We are not responsible for any costs that may incur if flares were painted without test fitting.

- Clean surface to be painted with a good grade degreaser. Do not use lacquer thinner or any solvent based product.
- Wipe flare surface completely dry with a tack rag prior to paint.
- Application of plastic adhesion promoter for PP plastic as per your paint system manufacturer's recommendations is required.
- Use a high quality enamel or polyurethane automotive paint to paint the flares.
- Not recommend to paint the edge trim, but if desired use a flex additive.

#### TOOLS FOR EASIER INSTALLATION

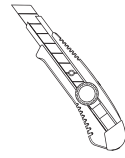

Utility Knife

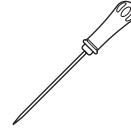

Awl



#2 Phillips Driver



1/2" Wrench



Socket Wrench



8mm Socket

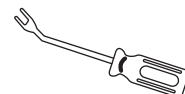

Plastic Fastener Remover Tool



Work Gloves

#### HARDWARE KIT INCLUDED



[A] Edge Trim



[B] SS Torx Screw



[C] SS Washer



[D] Nylock Nut



[E] T45 Torx Bit



[F] U-Clip



[G] PH Metal Screw



[H] Mylar Tab

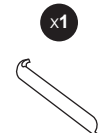

[I] Edge Trim Tool

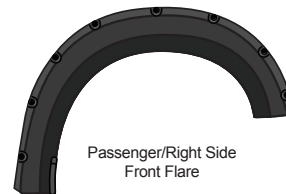

Passenger/Right Side Front Flare

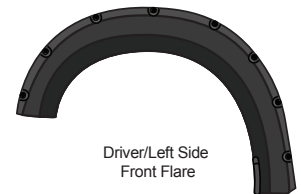

Driver/Left Side Front Flare



Passenger/Right Side Rear Flare



Driver/Left Side Rear Flare

DAMAGED or MISSING parts?

[www.TygerAuto.com/Contact](http://www.TygerAuto.com/Contact)





## EDGE TRIM INSTALLATION

- Peel 2 to 3" of red vinyl backing away from one end of the **Edge Trim [A]** .
- Apply **Edge Trim [A]** over top edge of flare with adhesive side contacting inside edge of flare.
- Press **Edge Trim [A]** into place and apply thumb pressure to ensure good adhesion, pull away red backing as you work your way around flare edge in one-foot increments.

### You will need:



Edge Trim [A]

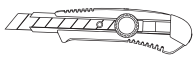

Utility Knife



### NOTE!

**DO NOT** stretch Edge Trim during application.

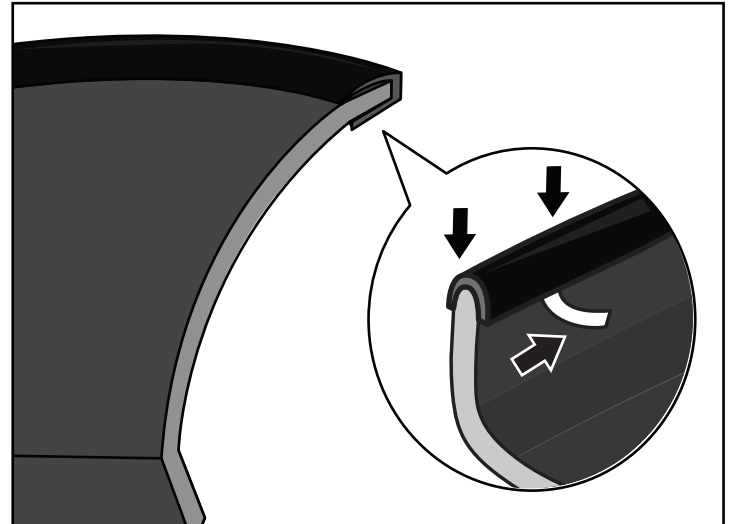

## EDGE TRIM CUTTING

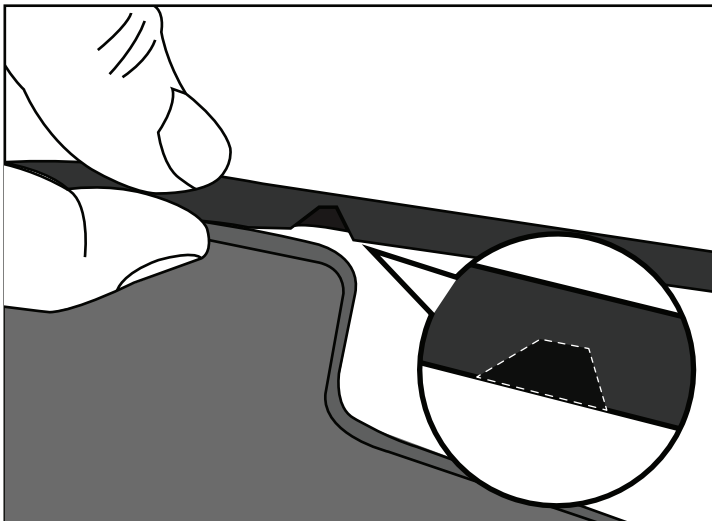

Begin from the **REAR FACING** end of the **FRONT** flare and apply edge trim toward the front. At the **OUTWARD**, 90° curve, cut a **NOTCH** off edge trim to prevent a bump from occurring as you wrap edge trim around the curve.

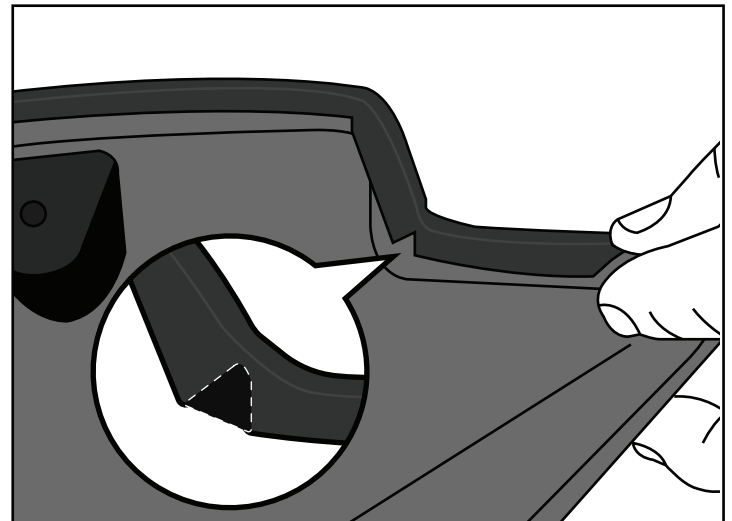

At the **INWARD**, 90° curve, cut a **WEDGE** off edge trim to prevent stretching from occurring as you wrap edge trim along the curve.



## DECORATIVE RIVET INSTALLATION

- Put a **Torx Bolt [B]** with a **Washer [C]** through each of the top holes around the flare and using a **Nylock Nut [D]** to secure on the other side. Using a socket wrench and the supplied **Torx Bit [E]** on an electric drill to tighten bolts. **DO NOT** over-tighten as this may damage the flare.

### You will need:

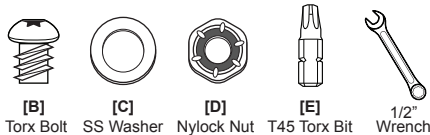

### ⚠ NOTE!

- **DO NOT** drill holes on the vehicle body as rivets are decorative and fasten only to the flare. Do not attempt to use the bolts to fasten flare to vehicle body.
- All exposed fasteners and bare metal should be treated with rust resistant paint before installing flares, Spray inner fender wells with undercoating after flare installation
- For vehicle with large tires may require lowering bump stops and/or installing steering stops to prevent tire from contacting flares
- Modification may be necessary to maintain a minimum 4" clearance between flares and exhaust pipes. (Exhaust gases should not vent directly onto flares)

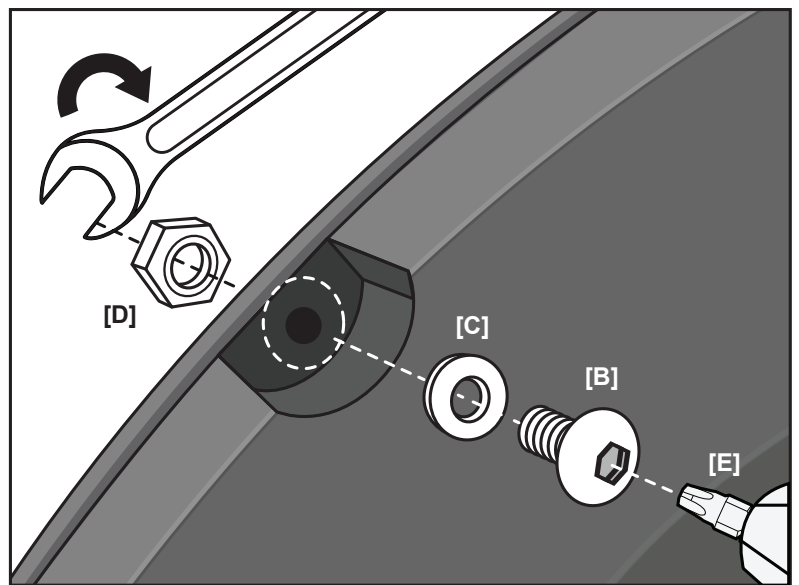

## FRONT FLARES INSTALLATION

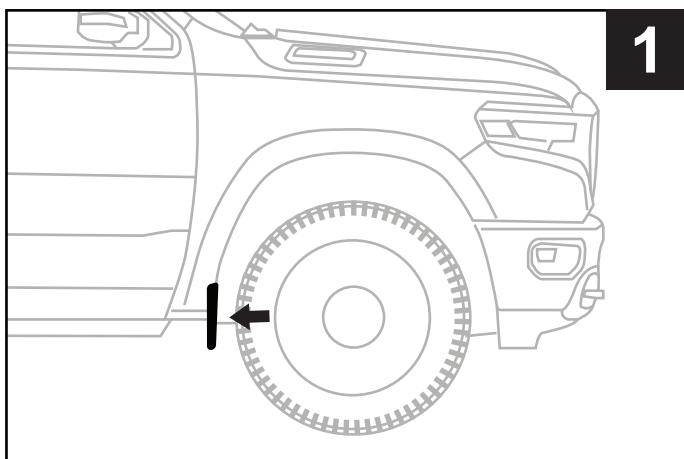

1. Start at factory FRONT wheel well mud flap on PASSENGER side.

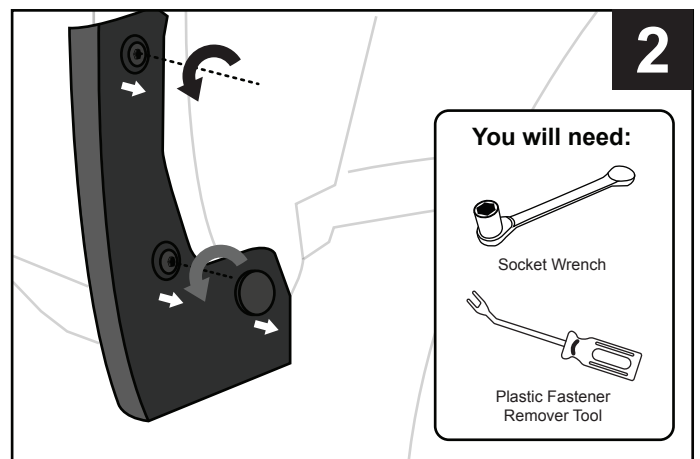

2. Remove 2 factory screws and 1 factory fastener from mud flap. Then uninstall the flap. Hold onto the screws. Fasteners may be disposed.



# TYGER<sup>®</sup>

3

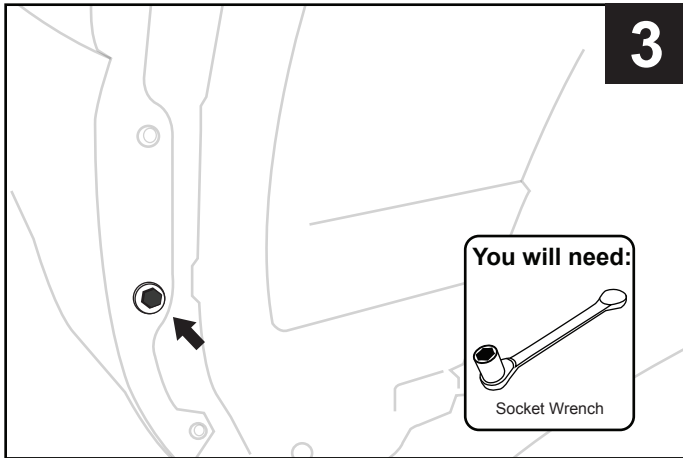

3. Re-apply 1 removed factory screw from **STEP 2** back to the lower hole (arrow). Hold onto remaining 1 factory screw.

4

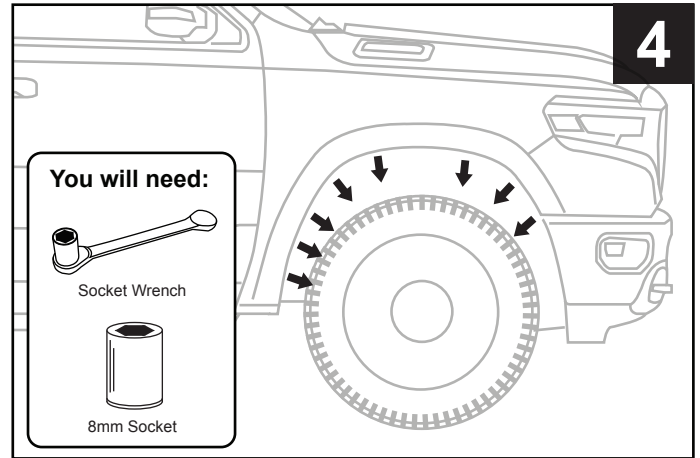

4. Remove and hold onto **8** factory screw from inside of wheel well. You should now have **9** total factory screws for flare installation.

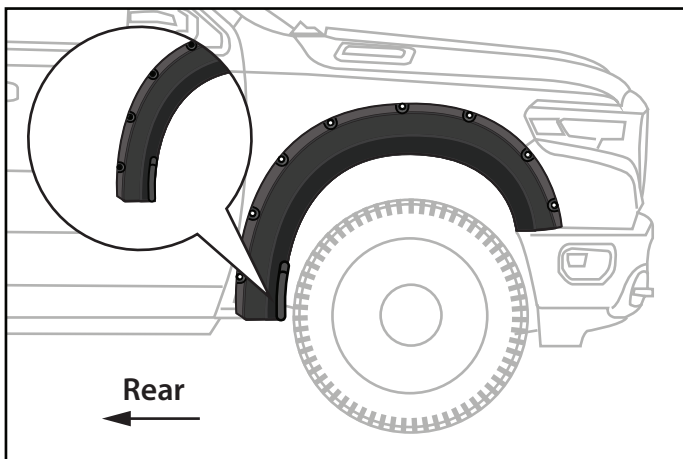

5. Secure flare against vehicle and apply **9** factory screws from **STEPS 3-4** without tightening.

5

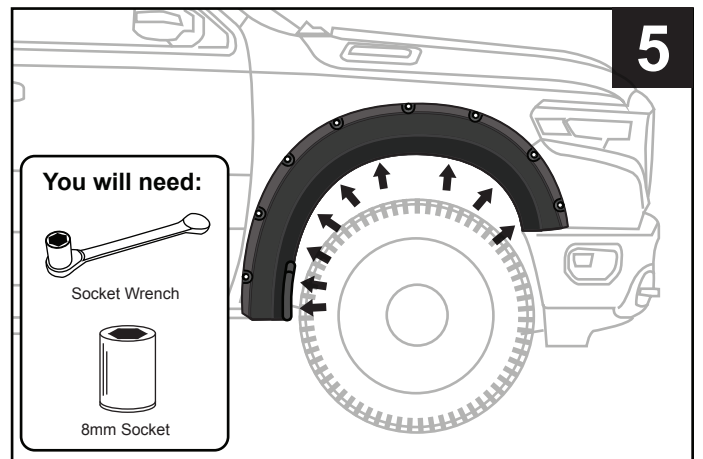

5. Secure flare against vehicle and apply **9** factory screws from **STEPS 3-4** without tightening.

6

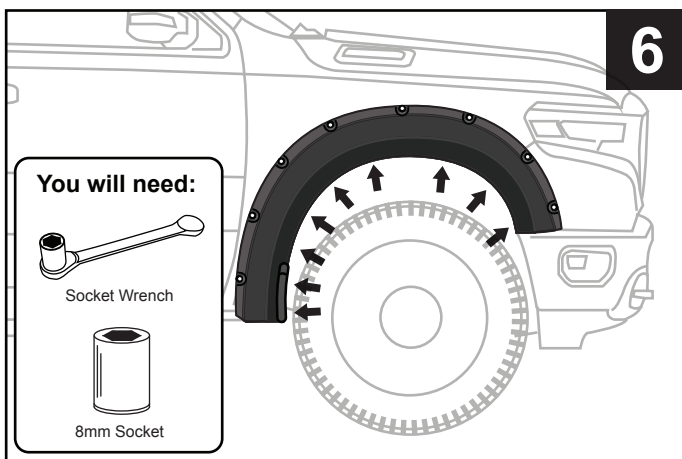

6. Tightly press flare against vehicle to evenly remove space between flare and vehicle. Tighten all **9** screws.

7

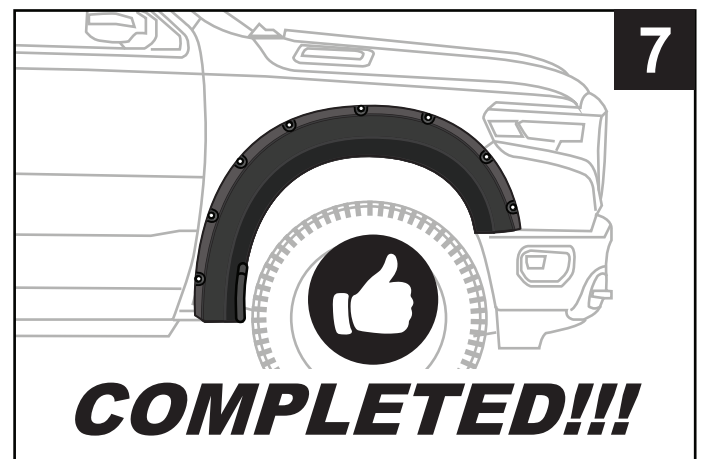

7. Front flare completed. Now onto rear flare installation.



## REAR FLARES INSTALLATION

**NOTE:** Trucks without fender liners, the top 3 holes on the rear wheel well are empty

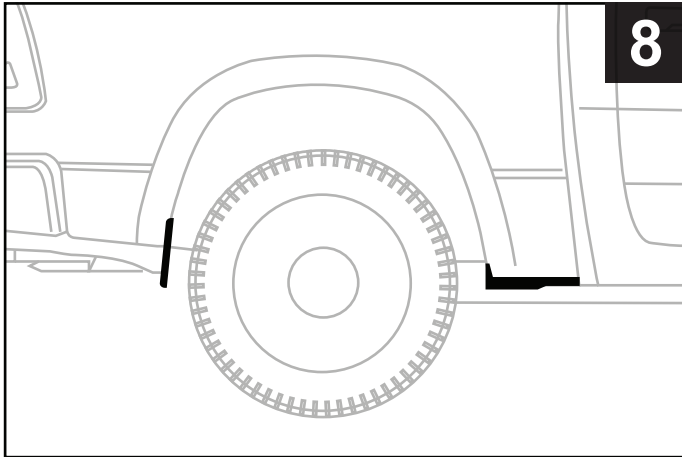

8. Start at 2 factory REAR wheel well mud flaps (vertical and horizontal) on PASSENGER side.

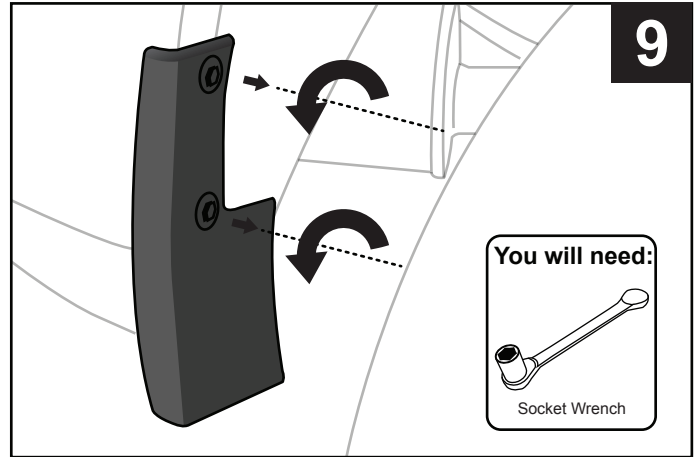

9. Remove 2 factory screws from vertical mud flap. Then uninstall the flap. Hold onto screws.

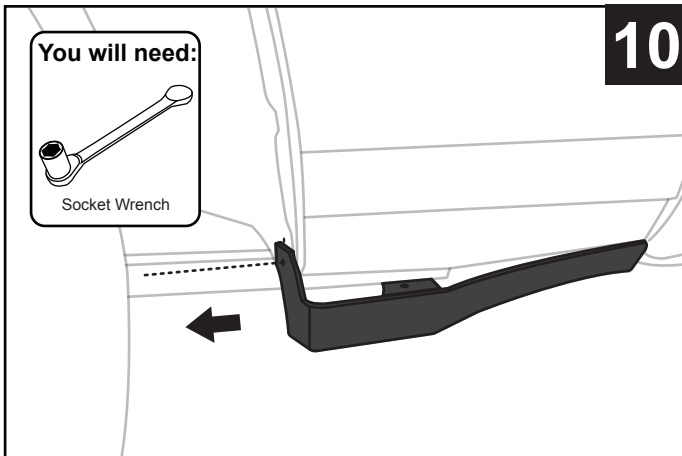

10. Remove 1 factory screw from horizontal mud flap. Then uninstall the flap. Hold onto screw (3 total).

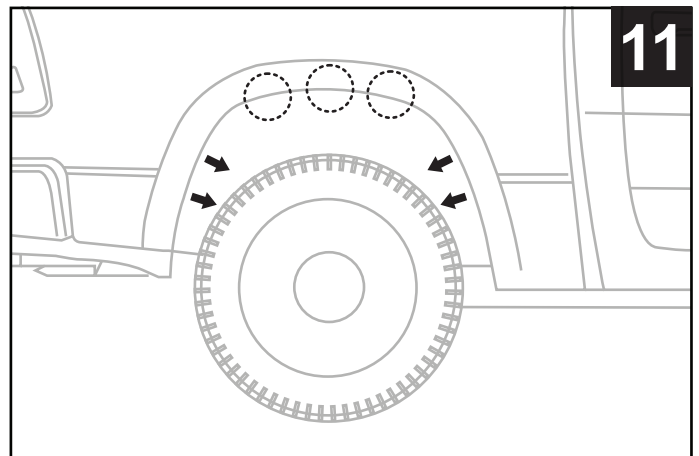

11. Remove 4 factory screws from inside of wheel well. Hold onto screws. You should have 7 factory screws for flare installation. Circles indicate factory hole locations for STEP 12.

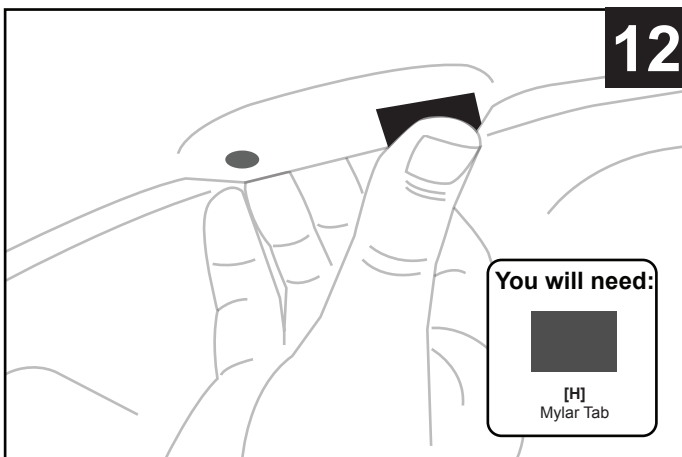

12. Apply supplied Mylar Tab [H] over factory holes.

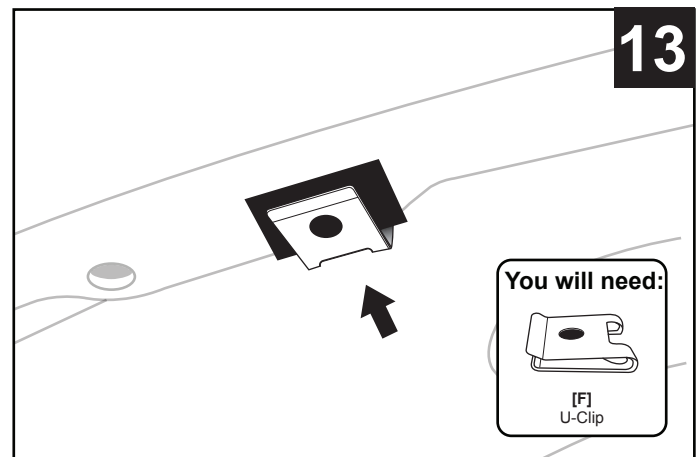

13. Install supplied U-Clip [F] by lining up clip hole with factory hole covered by Mylar Tab.

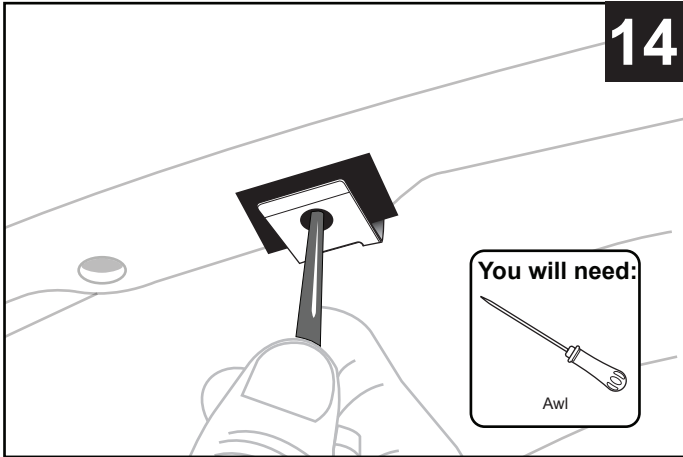

14. Poke a hole through U-Clip and Mylar Tab in a straight line using an awl or other pointed tools. Repeat STEPS 12-14 for remaining 2 factory hole locations indicated in STEP 11.

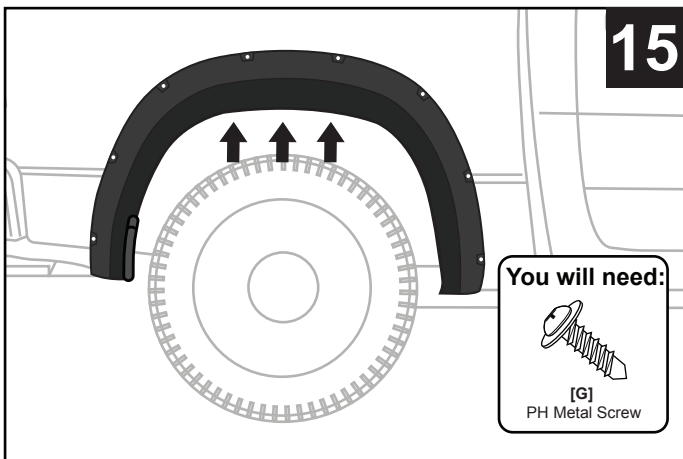
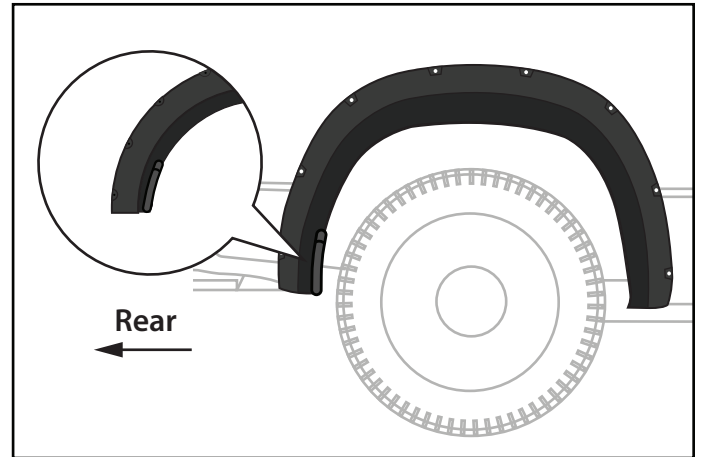

15. Secure flare against vehicle and apply 3 supplied PH Metal Screws [G] using a Phillips screwdriver without tightening.

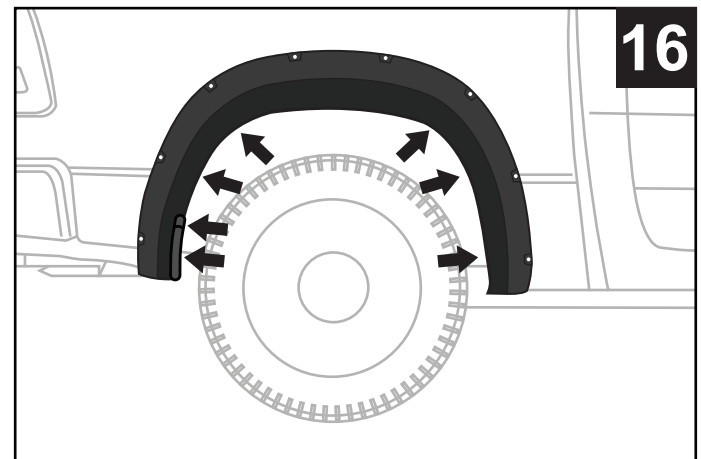

16. Still securing flare, apply 7 factory screws (from STEPS 9-11) to their original factory holes without tightening.

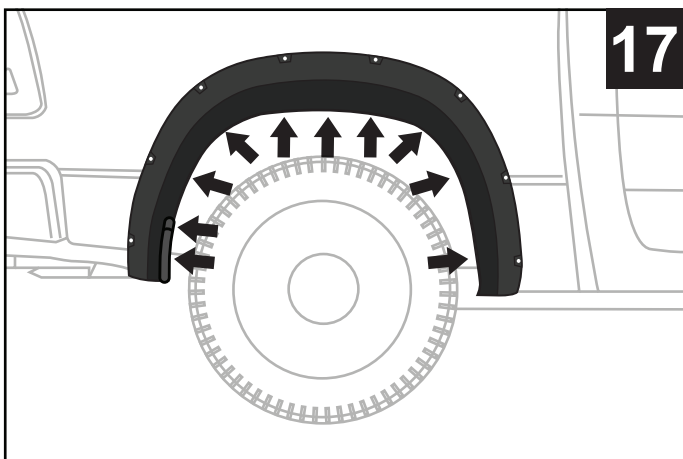

17. Tightly press flare against vehicle to evenly remove space between flare and vehicle. Tighten all 10 screws.



18. Rear flare without fender liners completed. Now onto rear flare with fender liners installation.



# TYGER<sup>®</sup>

## TRUCKS EQUIPPED WITH FENDER LINERS

**NOTE:** Trucks equipped with fender liners will have 3 factory screws at the top of the fender.

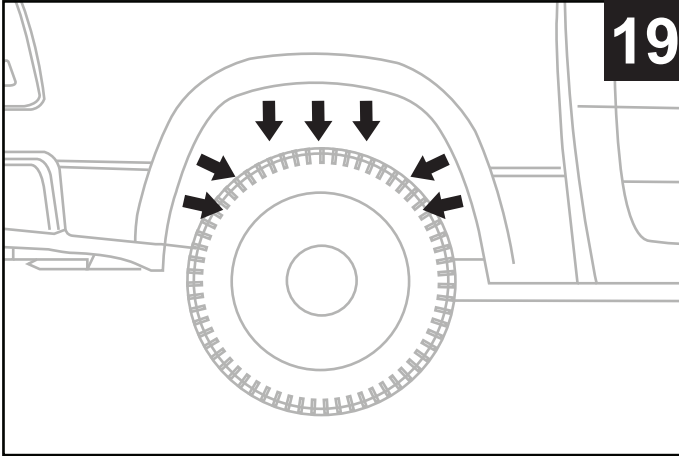

19. Repeat **STEPS 8-10**. Then remove **4** factory screws from inside of wheel well. Hold onto screws. You should have **10** factory screws for flare installation.

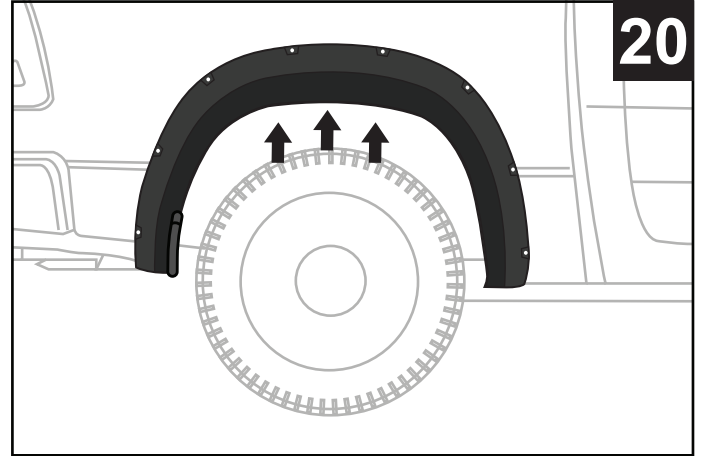

20. Secure flare against vehicle and apply **3** factory screws from **STEP 19** without tightening.

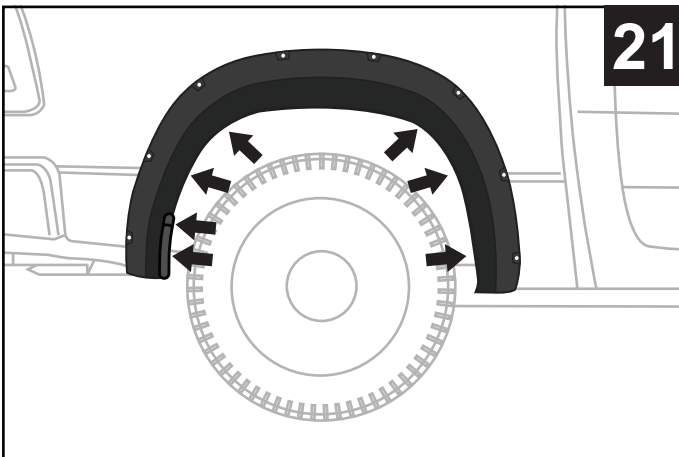

21. Still securing flare, apply remaining **7** factory screws to their original factory holes without tightening.



22. Tightly press flare against vehicle to evenly remove space between flare and vehicle. Tighten all **10** screws. Installation complete.

## EDGE TRIM TOOL USAGE (OPTIONAL):

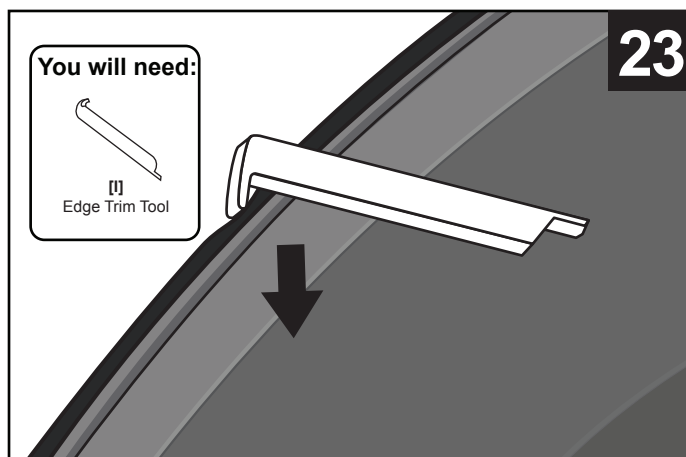

23. If needed, use supplied **Edge Trim Tool [I]** to trim outer edge by inserting the curved end, then sliding around the entire trim from one end to the other.

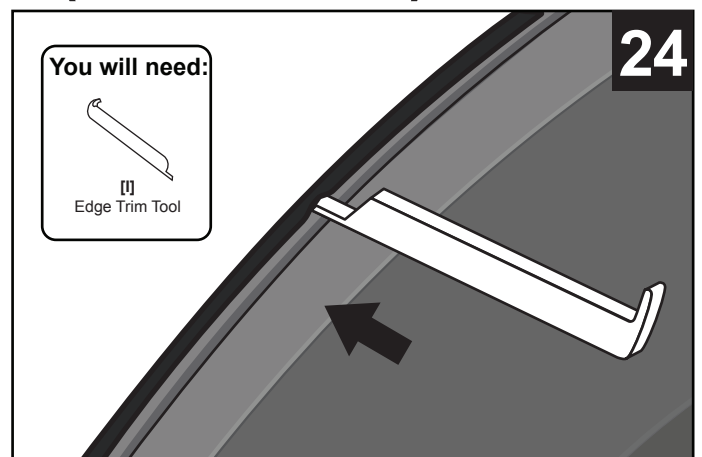

24. If needed, use supplied **Edge Trim Tool [I]** to trim inner edge by inserting the straight end, then sliding around the entire trim from one end to the other.



# TYGER<sup>®</sup>

## FITMENT OR GAP ISSUE?

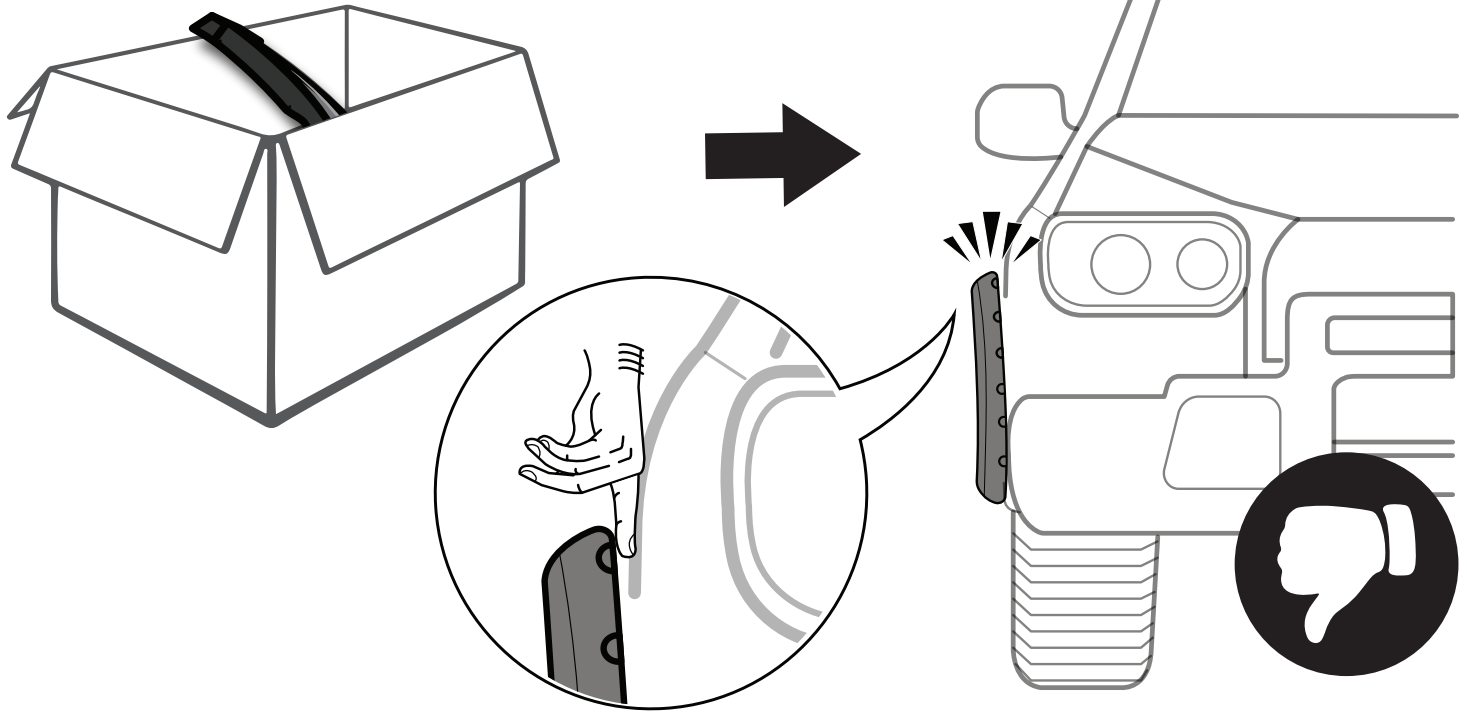

## SOLUTION!

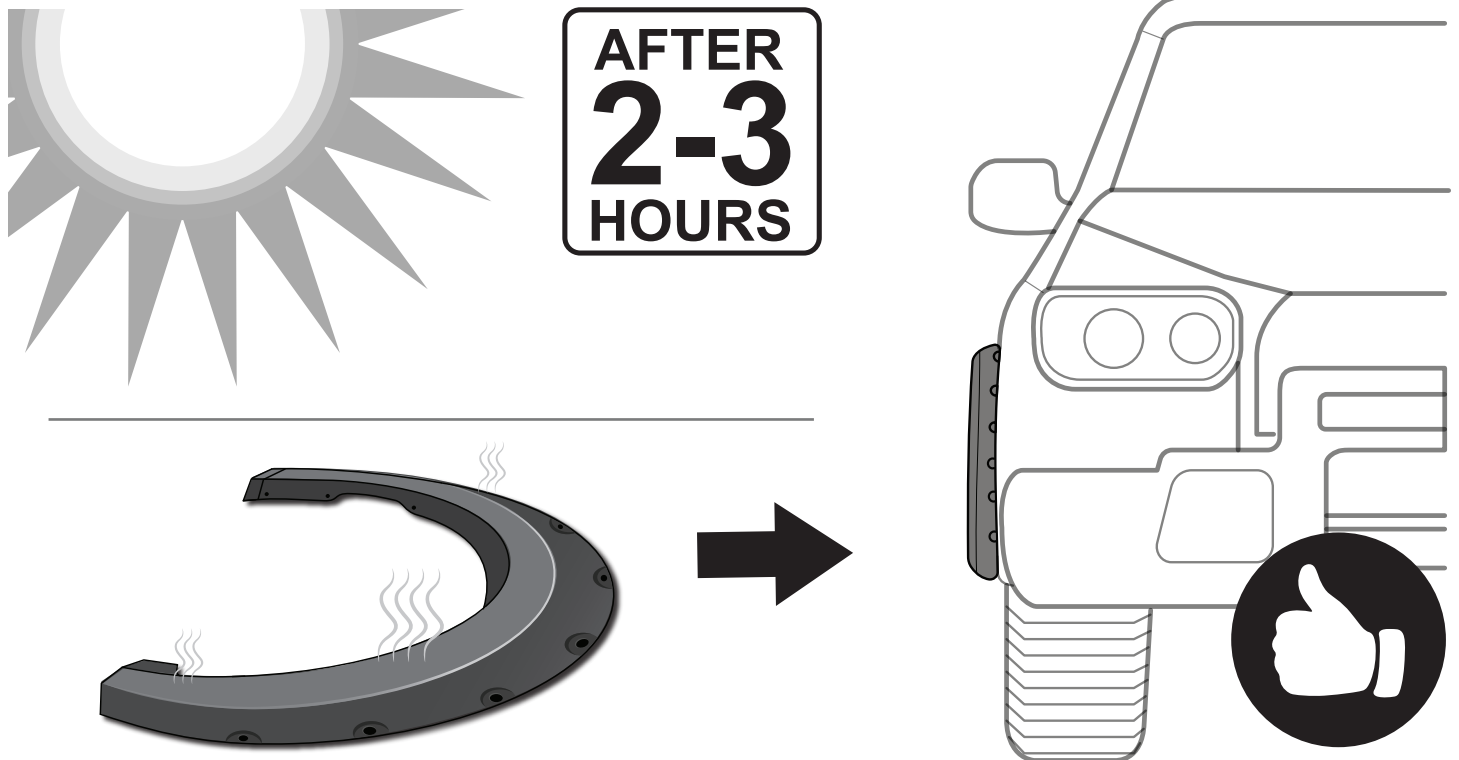

\*In winter, heat gun or hair dryer may be used instead.