



TYGER®

TYGER LED LIGHT BRACKETS

TG-GD2U27777:
Fit on TYGER GUARD only.

Before Installation

REMOVE CONTENTS FROM BOX. VERIFY ALL PARTS ARE PRESENT. READ INSTRUCTIONS CAREFULLY BEFORE STARTING INSTALLATION. CUTTING MAY BE REQUIRED. ASSISTANCE IS RECOMMENDED

Parts List

-  **x1**
Passenger/right LED Light Bracket
-  **x1**
Driver/left LED Light Bracket
-  **x4**
8mm x 22mm OD x 2mm Flat Washers
-  **x2**
8mm-1.25 x 25 Button Head Bolts
-  **x2**
8mm-1.25 x 16 Button Head Bolts
-  **x2**
8mm Nylon Lock Nuts
-  **x2**
8mm x 16mm x 1.5mm Flat Washers
-  **x1**
Wrench S=5

Tools Required

- x1** 13mm Wrench/Socket

STEP 1

Select the L/R "L" Brackets, (Figure 1). NOTE: "L" Brackets are offset for universal fitment for most LED bar style lights. Attach the LED light assembly to the "L" Brackets with the included (2) 8mm x 16mm Hex Bolts and (2) 8mm x 16mm Small Flat Washers, (Figure 1). Do not fully tighten hardware at this time. NOTE: "L" Brackets may require modification for hardware larger than 8mm or use brackets supplied with light instead.

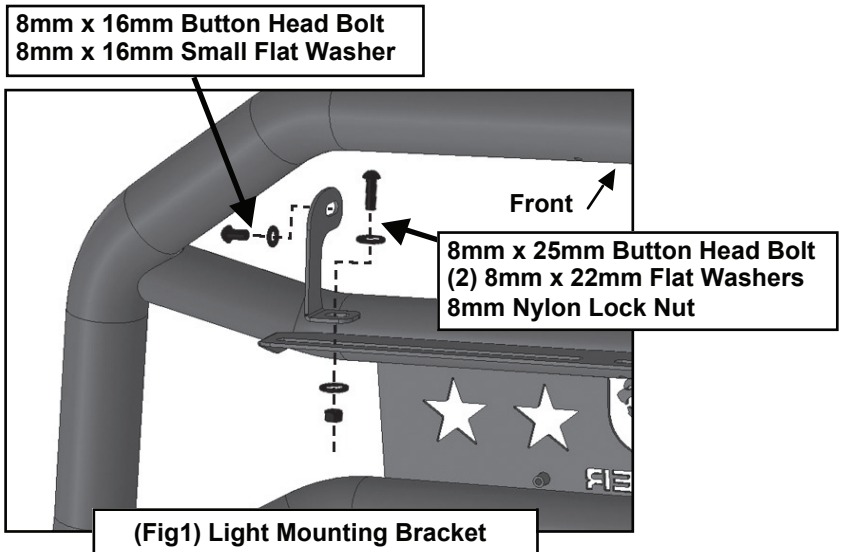

STEP 2

Attach the light and brackets to the top of the slots on the back of the Bumper with the included (2) 8mm x 25mm Hex Bolts, (4) 8mm Flat Washers and (2) 8mm Nylon Lock Nuts, (Figure 1). Adjust light position and tighten hardware.

STEP 3

Follow light manufacturer's instructions to wire the light to the vehicle's electrical system once Bumper has been fully installed.

STEP 4

Do periodic inspections to the installation to make sure that all hardware is secure and tight.