



TYGER®

TYGER GUARD™

TG-GD6T60458

BEFORE INSTALLATION

READ INSTRUCTIONS CAREFULLY BEFORE STARTING INSTALLATION. REMOVE CONTENTS FROM BOX AND VERIFY ALL PARTS ARE PRESENT. ASSISTANCE IS RECOMMENDED. FAILURE TO IDENTIFY DAMAGE BEFORE INSTALLATION COULD LEAD TO A REJECTION OF ANY CLAIM. IF ANY DAMAGE FOUND, PLEASE TAKE A PICTURE FOR THE CLAIM PURPOSE. PLEASE ALSO SEND THE PICTURES, ORDER NUMBER, AND DETAILS OF THE ISSUE TO SUPPORT@TYGERAUTO.COM.

TORQUE VALUE

Fastener Size	Class 8.8 Torque (ft-lbs)	Class 10.9 Torque (ft-lbs)
6mm	6-7	6-7
8mm	15-16	22-23
10mm	31-32	44-45
12mm	54-55	78-79
14mm	87-88	125-126

Parts List

- x1 Tyger Guard
- x1 Driver/left Frame Mounting Bracket
- x1 Passenger/right Frame Mounting Bracket
- x1 Driver/left side Support Bracket
- x1 Passenger/right side Support Bracket
- x1 Driver/left Tube Mounting Bracket
- x1 Passenger/right Tube Mounting Bracket
- x4 10-1.5mm x 35mm Hex Bolts
- x8 10mm x 27mm OD x 3mm Flat Washers
- x4 10-1.5mm Nylon Lock Nuts
- x6 10-1.5mm Flange Nuts
- x4 8-1.25mm x 35mm Hex Bolts
- x4 8mm x 22mm x 2mm Flat Washers
- x4 8mm Lock Washers
- x2 6-1.0mm x 20 Combination Bolts(license plate)
- x1 4mm Allen Wrench

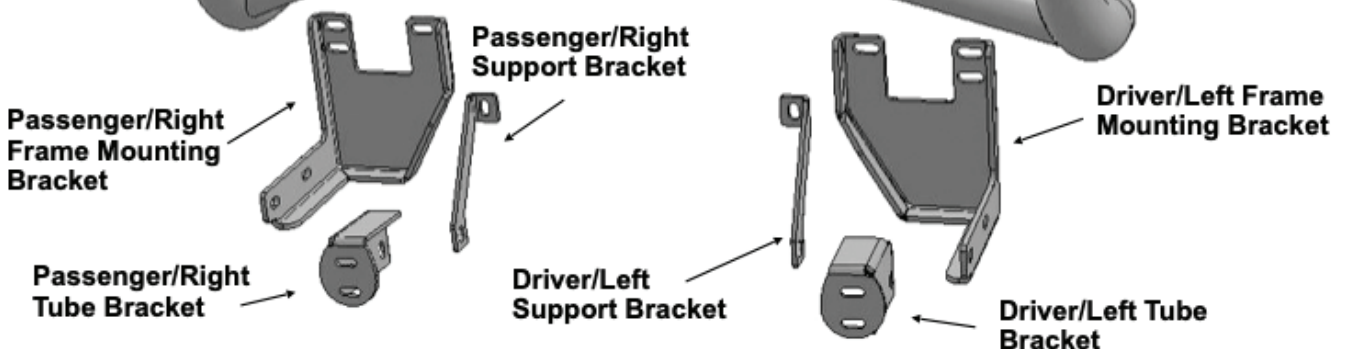



STEP 1

Start installation from under the front passenger/left side of the vehicle. Remove (3) factory hex flange nuts securing the bumper bracket to the end of the frame (Fig 1).

NOTE: Only remove the (3) factory hex nuts required to install the Mounting Bracket, (2 outside, 1 on the inside of the frame).

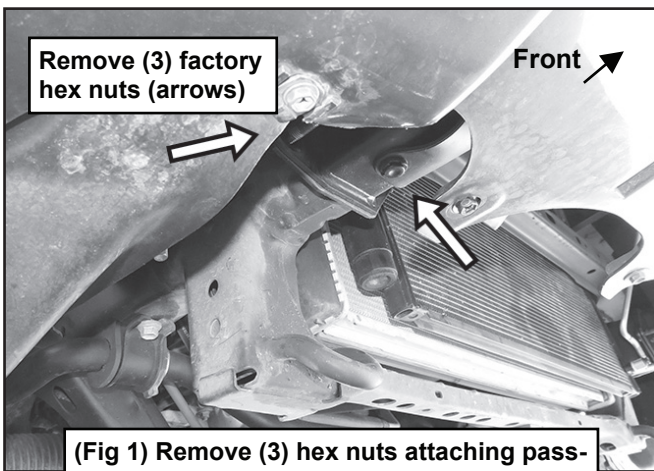

STEP 2

Select the passenger/right Frame Mounting Bracket and Support Bracket (Fig 2). Use (2) 10mm Flange Nuts to attach the Frame Bracket to the top (2) threaded studs on the frame (Fig 2).

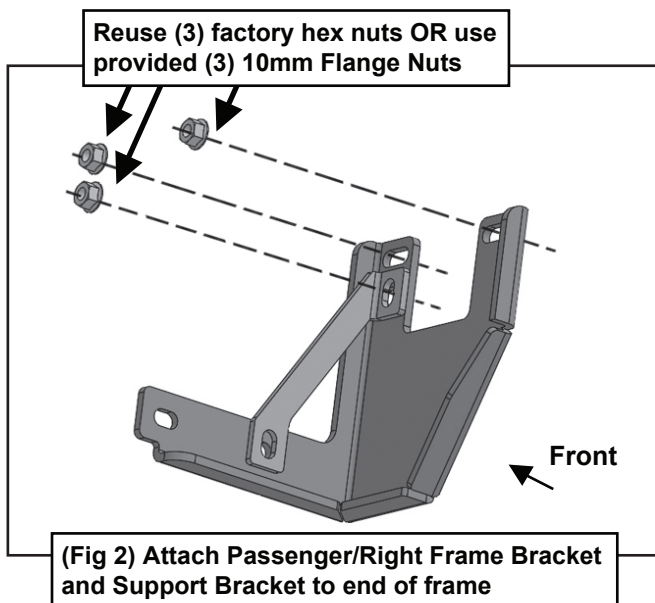

STEP 3

Next, attach the Passenger/right Support Bracket to the lower outer stud on the frame and Frame Bracket using the remaining 10mm Flange Nut (Fig 2). DO NOT tighten hardware at this time.

STEP 4

Next, select the passenger/right Tube Mounting Bracket (Fig 3). Slide the Bracket between the Frame and Support Bracket. Align the slots on the Tube Bracket to the slots on the Frame Bracket. Attach the Tube Bracket to the Frame and Support Bracket using (2) 10mm x 35mm Hex Bolts, (4) 10mm Flat Washers and (2) 10mm Nylon Lock Nuts (Figs 4 & 5). DO NOT tighten.

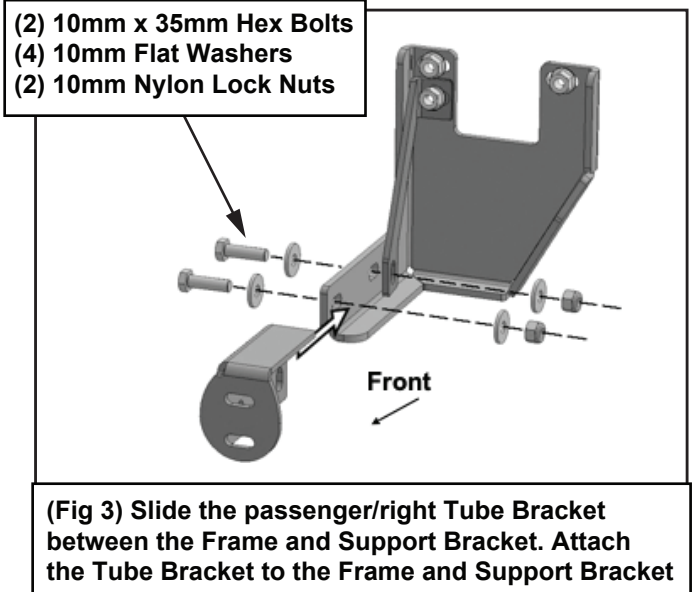

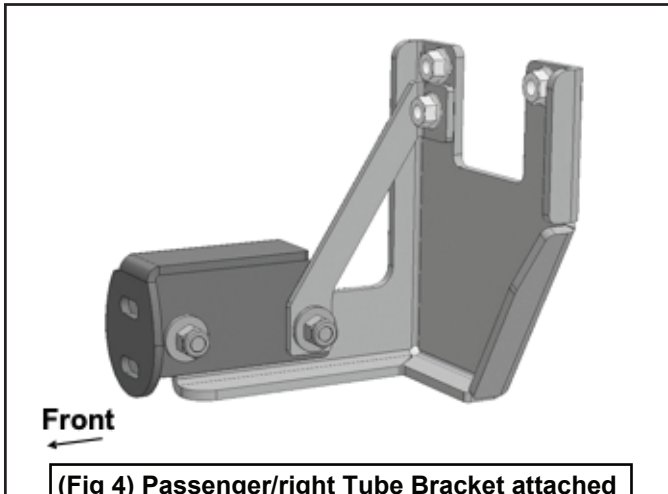

(Fig 4) Passenger/right Tube Bracket attached to the Frame and Support Bracket

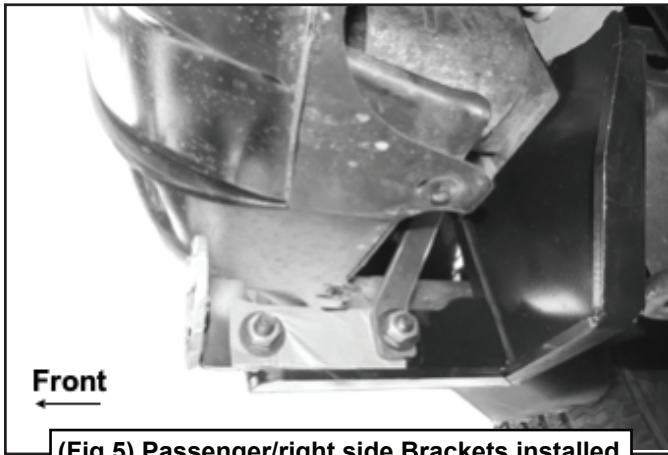

(Fig 5) Passenger/right side Brackets installed

STEP 5

Move to the driver/left side bumper bracket. Repeat **STEPS 1-4** to attach the driver/left side Frame Bracket, Support Bracket and Tube Bracket (Fig 6).

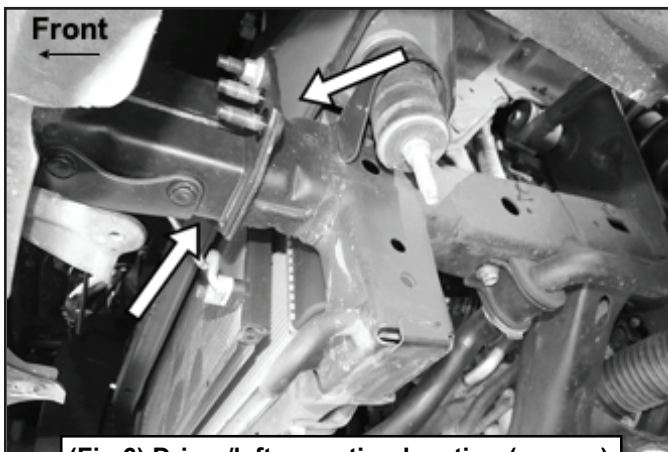

(Fig 6) Driver/left mounting location (arrows)

STEP 6

With assistance, attach the TYGER Guard to the ends of the Tube Brackets with the included (4) 8mm x 35mm Hex Bolts, (4) 8mm Lock Washers and (4) 8mm Flat Washers (Fig 7). **DO NOT** fully tighten hardware at this time.

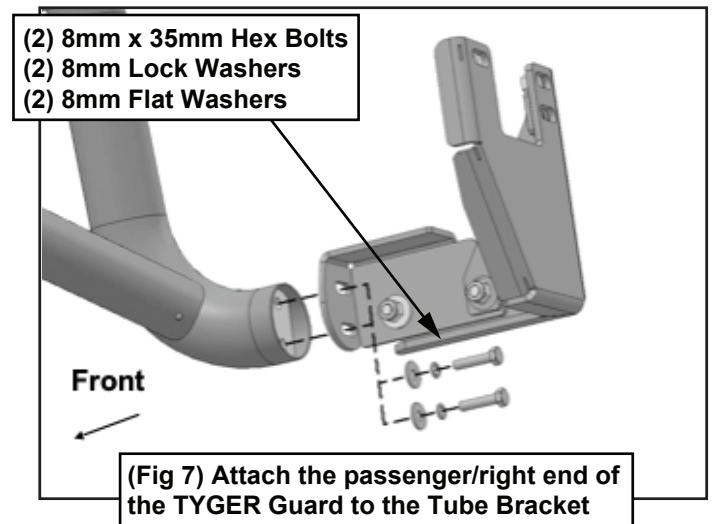

(Fig 7) Attach the passenger/right end of the TYGER Guard to the Tube Bracket

STEP 7

Level and adjust the TYGER Guard and tighten all hardware.

STEP 8

Use the included (2) 6mm x 20mm Combo Bolts to attach the license plate to the front of the TYGER Guard.

STEP 9

Do periodic inspections to the installation to make sure that all hardware is secure and tight.



TYGER®

