



TYGER®

TYGER KOBRA

TG-KB2C25011

Scan to Download the Latest Digital Version



BEFORE INSTALLATION

READ INSTRUCTIONS CAREFULLY BEFORE STARTING INSTALLATION. REMOVE CONTENTS FROM BOX AND VERIFY ALL PARTS ARE PRESENT. FAILURE TO IDENTIFY DAMAGE BEFORE INSTALLATION COULD LEAD TO A REJECTION OF ANY CLAIM. IF MISSING PARTS OR ANY DAMAGE FOUND, PLEASE TAKE A PICTURE FOR THE CLAIM PURPOSE. TO FILE YOUR CLAIM, PLEASE VISIT: WWW.TYGERAUTO.COM/CONTACT

TORQUE VALUES

Fastener Size	Class 8.8 Torque (ft-lbs)	Class 10.9 Torque (ft-lbs)
6mm	6-7	6-7
8mm	15-16	22-23
10mm	31-32	44-45
12mm	54-55	78-79
14mm	87-88	125-126

- x1** Driver/Left Tyger Kobra
- x1** Passenger/Right Tyger Kobra
- x4** Driver/Left Mounting Brackets [A]
- x1** Passenger/Right Front Mounting Bracket [B]
- x3** Passenger/Right Center/Rear Mounting Brackets [C]
- x1** Passenger/Right Front Support Bracket [D]
- x1** 8mm x 35mm T-shape Bolt Plate
- x1** 8mm x 1.25mm x 40mm Hex Bolt
- x1** 8mm Nylon Lock Nut
- x15** 8mm Clip Nuts
- x16** 8mm x 1.25mm x 25mm Hex Bolts
- x17** 8mm Lock Washers
- x17** 8mm x 24mm x 2mm Flat Washers
- x16** 8mm x 1.25mm x 25mm Hex Combo Bolts

Parts List

Top View

ATTENTION: Refer to **D** and **P** labelling on the side of the tubes to determine Driver and Passenger TYGER Kobra

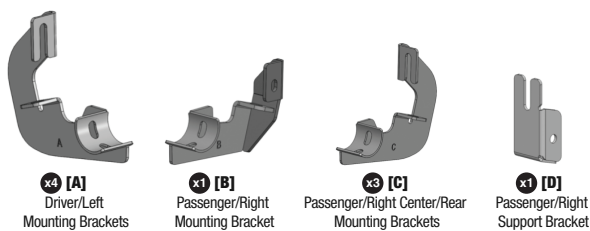
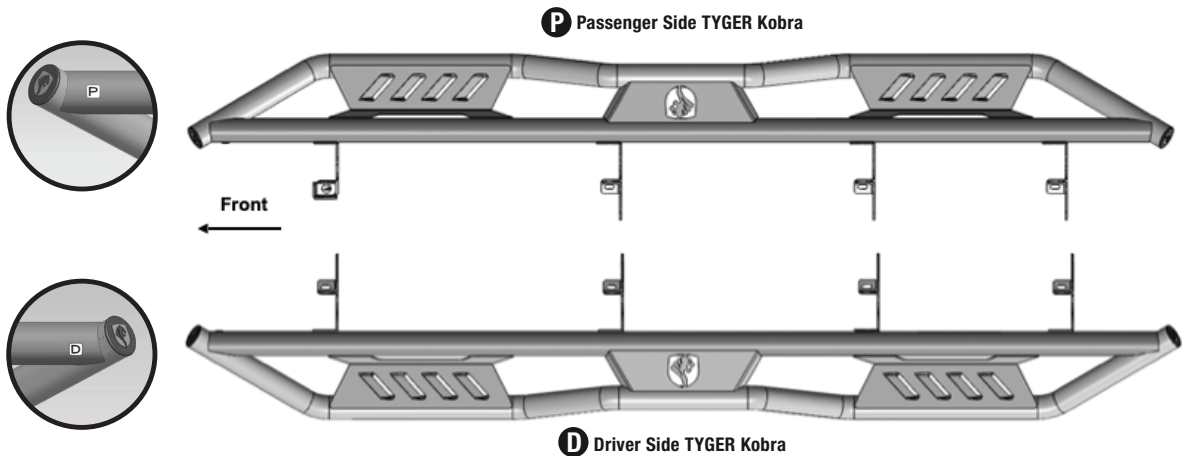

- 8mm x 35mm T-shaped Bolt Plate
- Flat Washer
- 8mm Clip Nut
- x1** 8mm x 35mm T-shaped Bolt Plate
- x17** 8mm x 24mm x 2mm Flat Washers
- x15** 8mm Clip Nuts
- Hex Bolt
- Nylon Lock Nut
- Lock Washers
- x1** 8mm x 1.25mm x 40mm Hex Bolt
- x1** 8mm Nylon Lock Nut
- x17** 8mm Lock Washers
- x16** 8mm x 1.25mm x 25mm Hex Bolts
- Combo Bolt
- x16** 8mm x 1.25mm x 25mm Hex Combo Bolts

Reference the letters printed on the brackets to determine mounting locations

Top View

D Driver Side TYGER Kobra

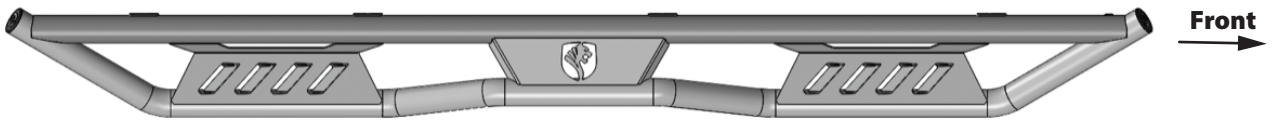
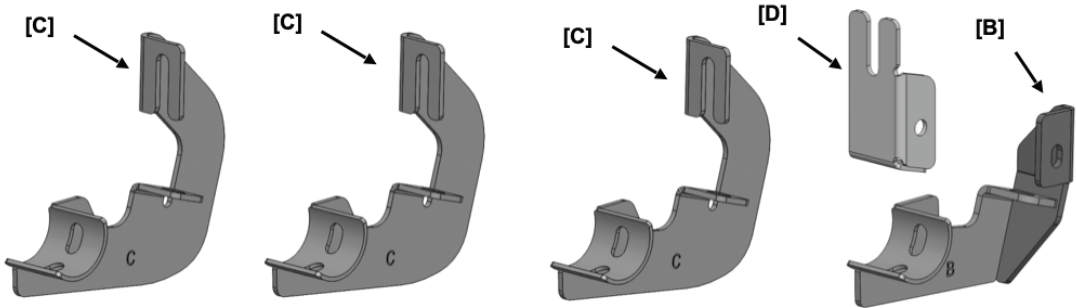
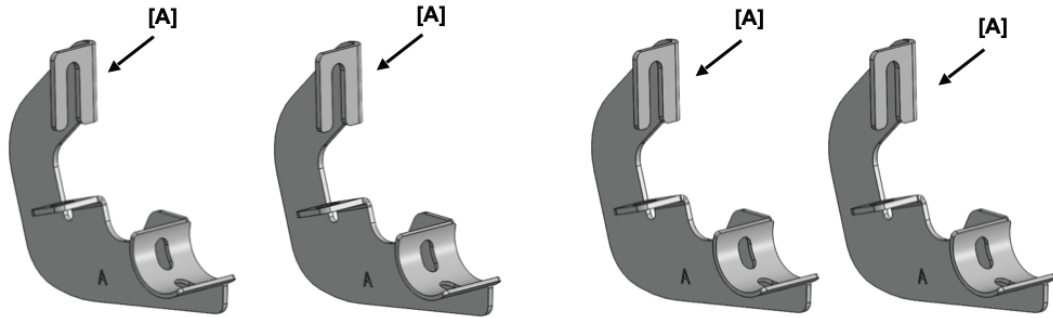

P Passenger Side TYGER Kobra

Bottom View

D Driver Side TYGER KOBRA

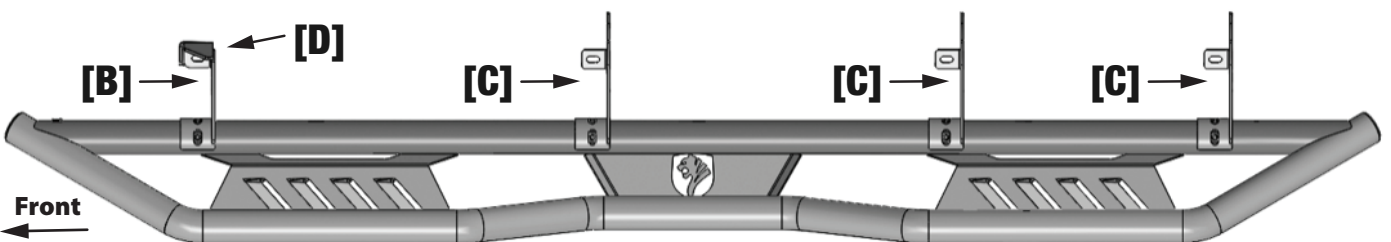
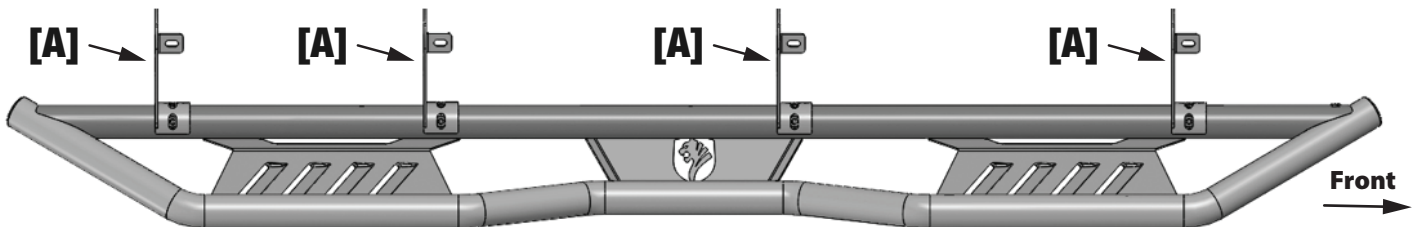

P Passenger Side TYGER KOBRA

TOOLS REQUIRED

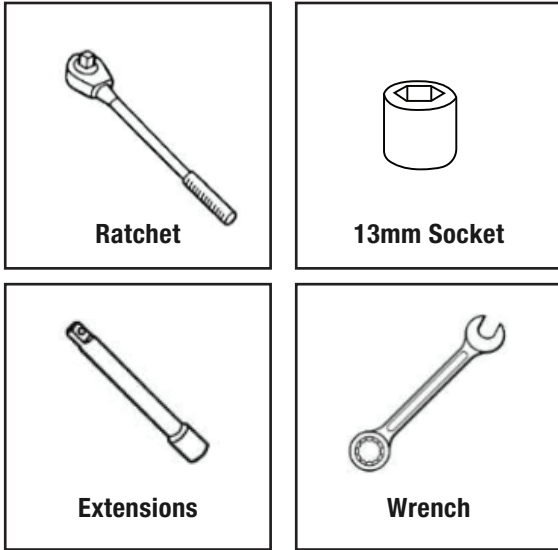

STEP 1 MOUNTING BRACKETS

Follow (Fig 1 – 7) to attach Driver/Left Mounting Brackets **[A]** to the 4 mounting locations on Driver/Left side. Repeat the following steps with Passenger/Right Center & Rear Mounting Brackets **[C]** for the passenger/right 2nd, 3rd, and rear mounting locations. Ensure all hardware is hand tightened at this point.

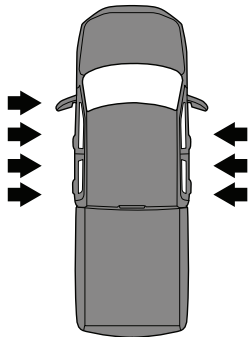

Driver-side Mounting Area

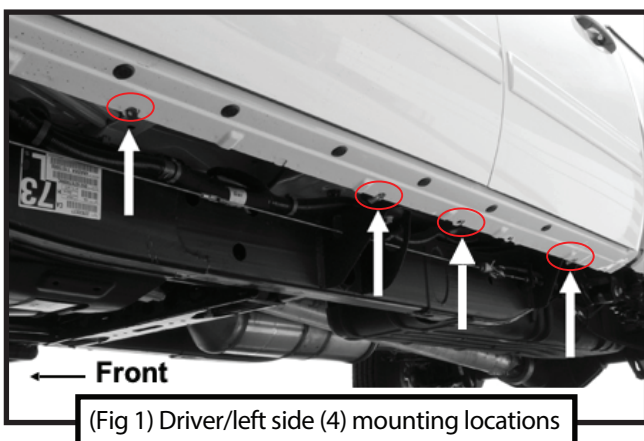

Driver-side Center Mounting Area

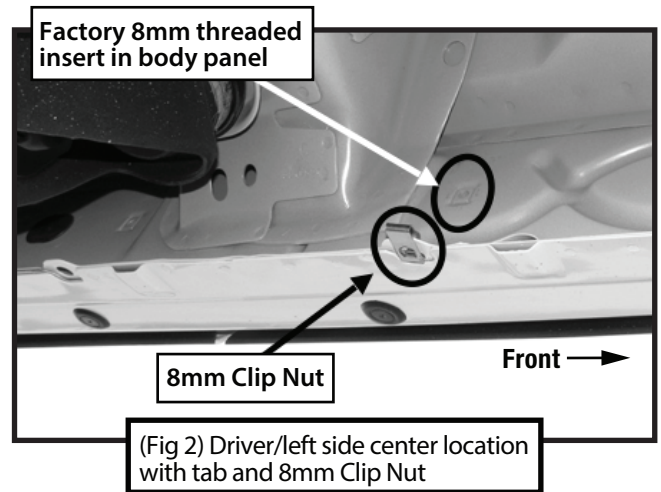

Driver-side Rear Mounting Area

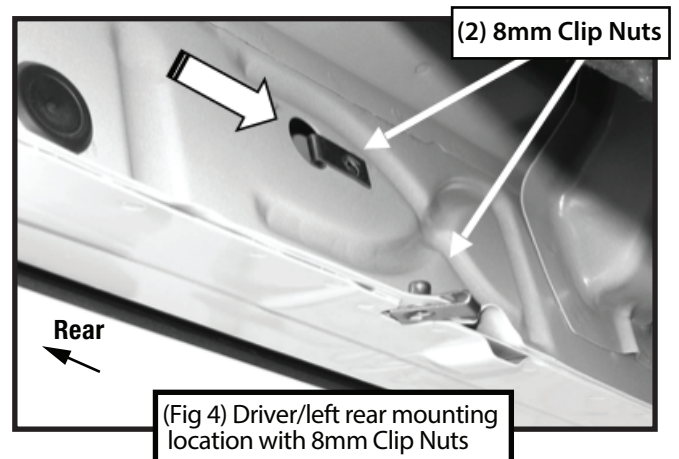
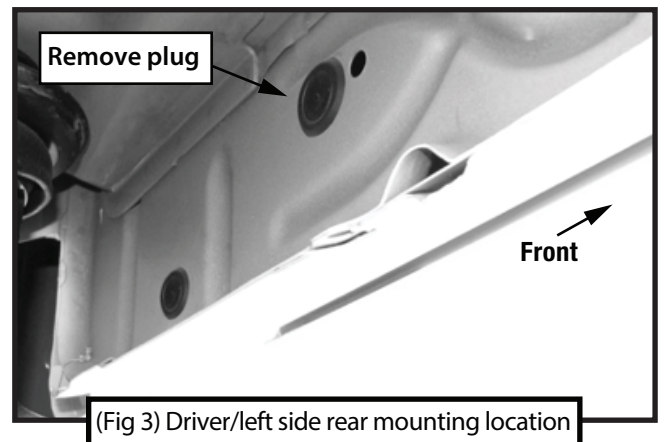

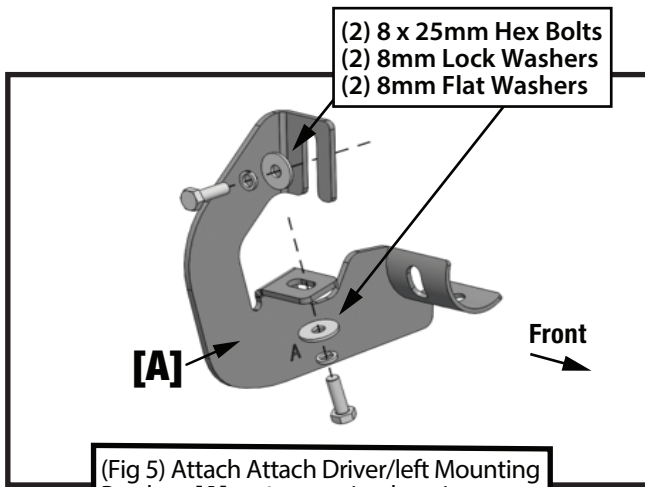

(Fig 5) Attach Attach Driver/left Mounting Brackets [A] to 4 mounting locations

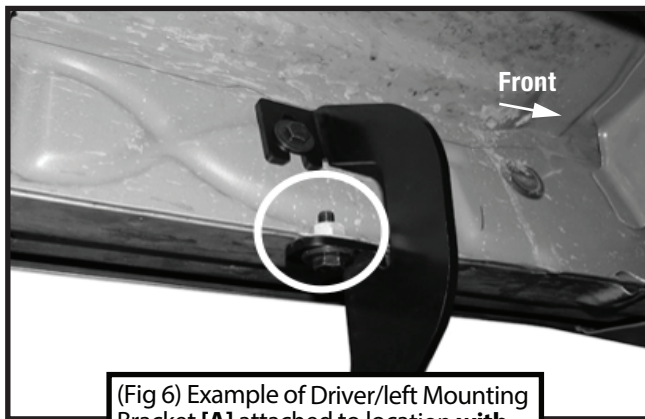

(Fig 6) Example of Driver/left Mounting Bracket [A] attached to location **with factory threaded mounting holes**

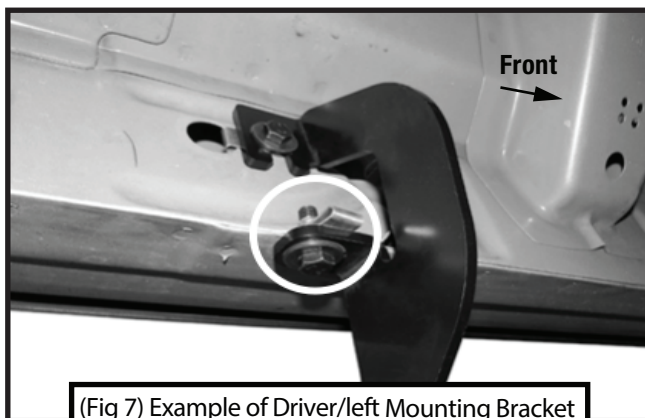

(Fig 7) Example of Driver/left Mounting Bracket attached to location **with 8mm Clip Nuts**

STEP 2 PASSENGER SIDE FRONT MOUNTING BRACKET

Follow (Fig 8 – 19) to remove DEF tank cover and install the Passenger/Right Front Mounting and Support Brackets. Ensure all hardware is hand tightened at this point.

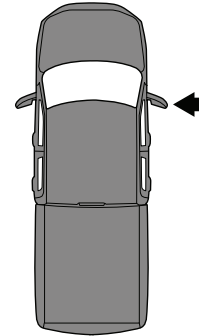

For model years **2007- 2016:**

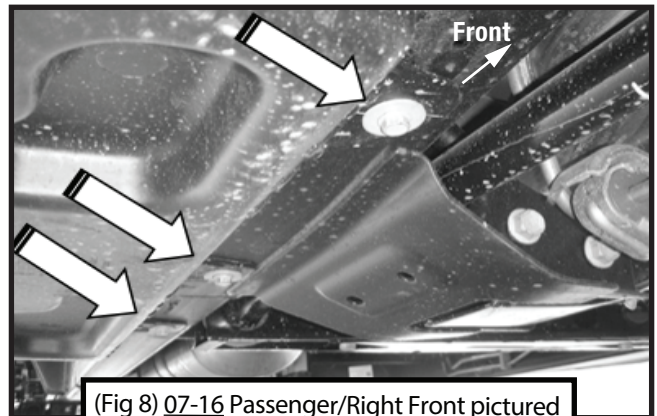

(Fig 8) 07-16 Passenger/Right Front pictured with DEF tank cover. Remove (3) hex bolts to remove cover

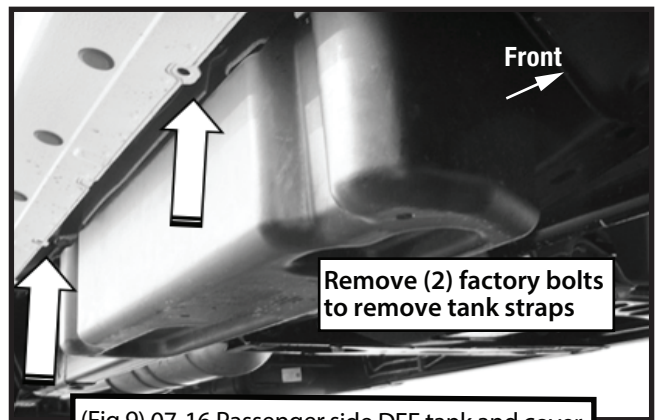

(Fig 9) 07-16 Passenger side DEF tank and cover

Remove (2) factory bolts to remove tank straps

For model years **2007- on:**

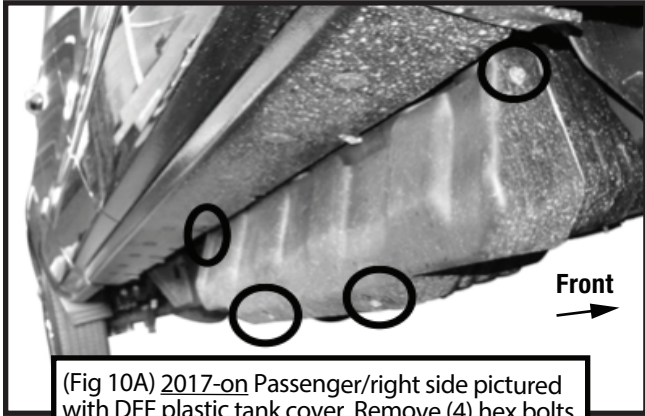

(Fig 10A) 2017-on Passenger/right side pictured with DEF plastic tank cover. Remove (4) hex bolts to remove plastic cover

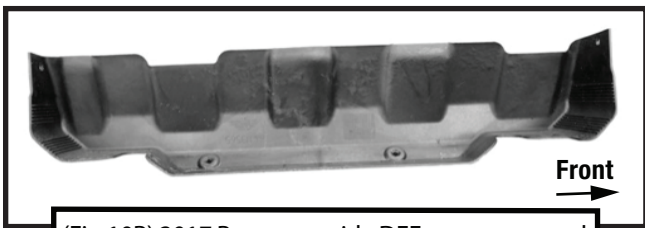

(Fig 10B) 2017 Passenger side DEF cover removed

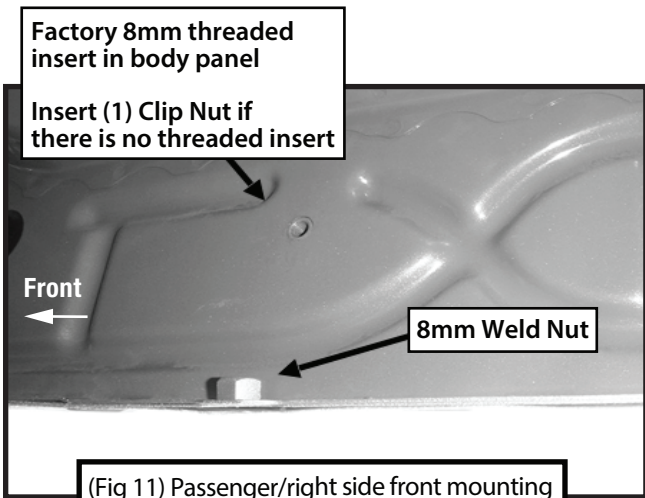

(Fig 11) Passenger/right side front mounting location with weld nut pictured for example

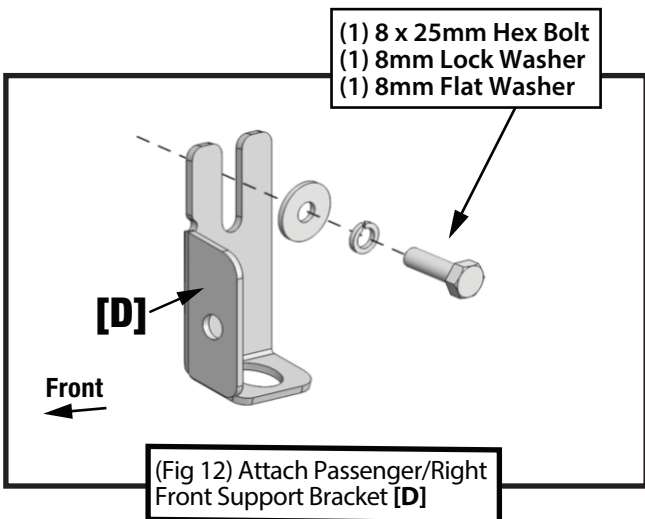

(Fig 12) Attach Passenger/Right Front Support Bracket [D]

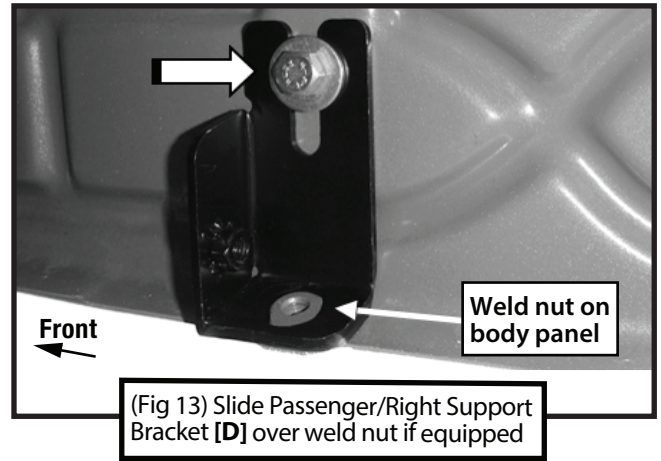

(Fig 13) Slide Passenger/Right Support Bracket [D] over weld nut if equipped

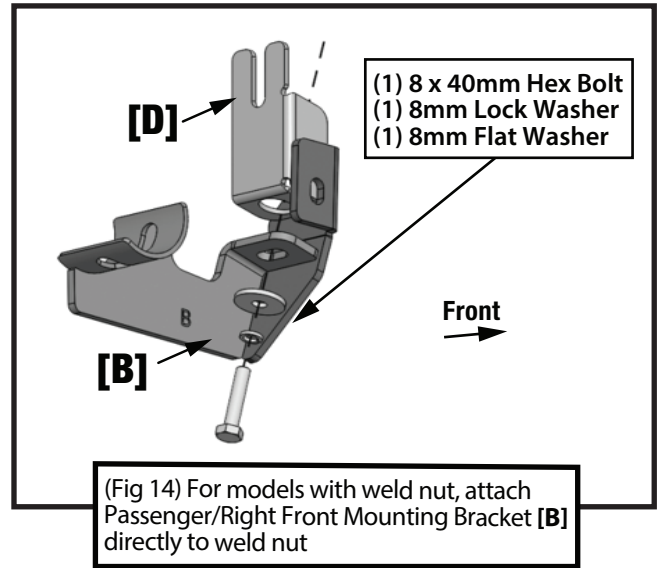

(Fig 14) For models with weld nut, attach Passenger/Right Front Mounting Bracket [B] directly to weld nut



(Fig 15) 8mm x 35mm Bolt Plate

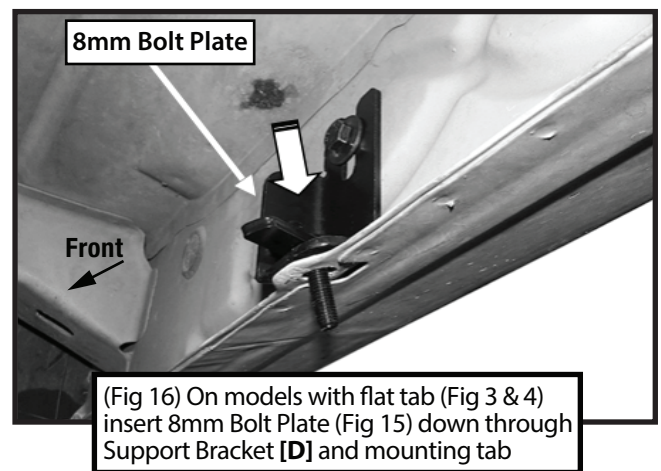

(Fig 16) On models with flat tab (Fig 3 & 4) insert 8mm Bolt Plate (Fig 15) down through Support Bracket [D] and mounting tab

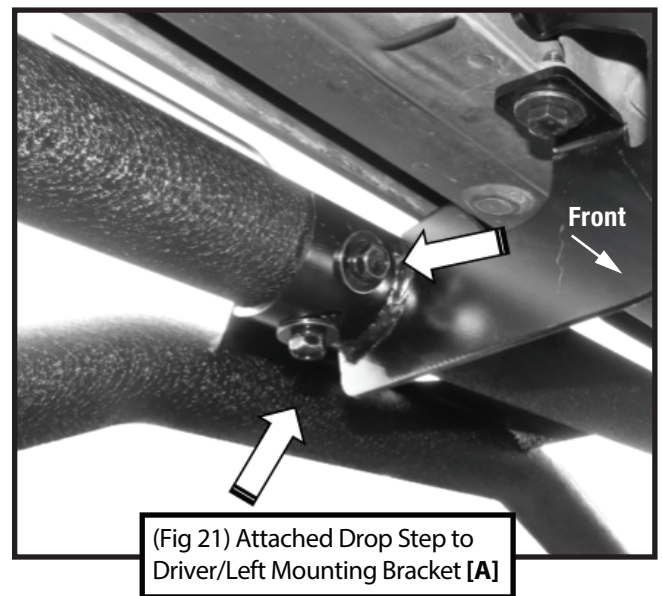
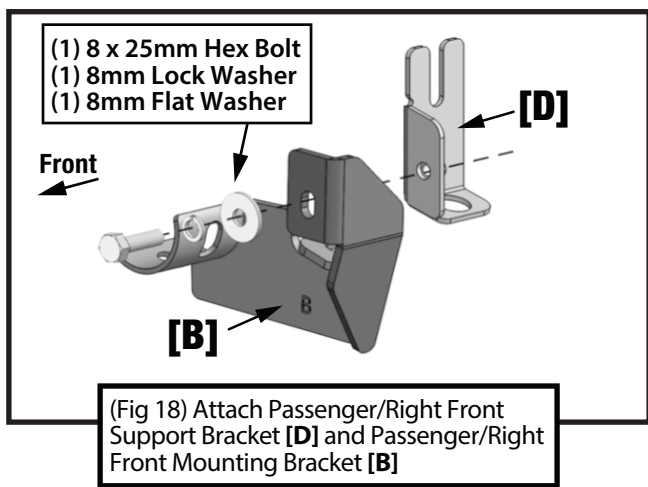
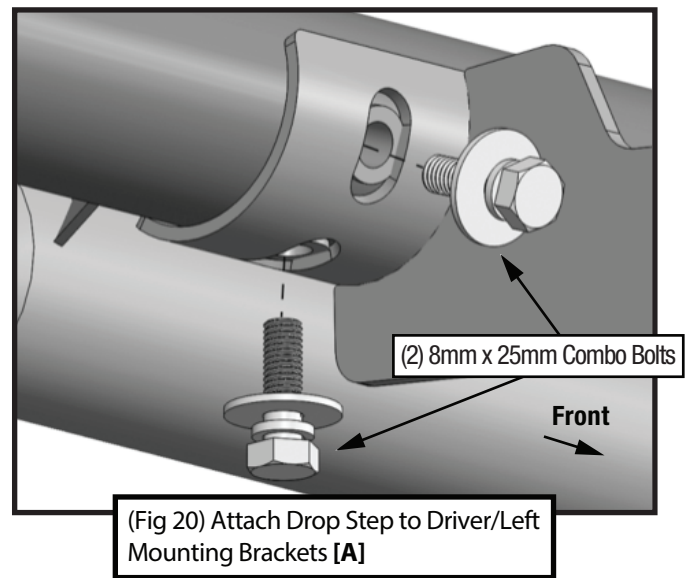
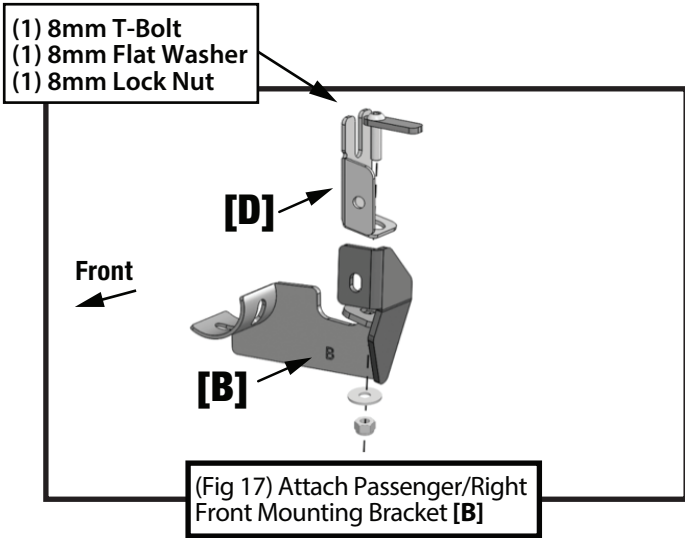

STEP 4 COMPLETION

STEP 4 **COMPLETION**

Ensure Tyger Kobra Drop Step is level and straightened, then tighten all fasteners. Installation is complete. Perform periodic inspections to the installation to make sure that all hardware is secure and tight.



STEP 3 MOUNTING RUNNING BOARD

Follow (Fig 20 – 21) to install the Kobra Drop Step on the Driver/Left side. Ensure all hardware is hand tightened at this point.

Repeat the same steps to install Kobra Drop Step on the Passenger/Right side.