



TYGER KOBRA

TG-KB2D25004

Scan to Download the Latest Digital Version



BEFORE INSTALLATION

READ INSTRUCTIONS CAREFULLY BEFORE STARTING INSTALLATION. REMOVE CONTENTS FROM BOX AND VERIFY ALL PARTS ARE PRESENT. FAILURE TO IDENTIFY DAMAGE BEFORE INSTALLATION COULD LEAD TO A REJECTION OF ANY CLAIM. IF MISSING PARTS OR ANY DAMAGE FOUND, PLEASE TAKE A PICTURE FOR THE CLAIM PURPOSE. TO FILE YOUR CLAIM, PLEASE VISIT: WWW.TYGERAUTO.COM/CONTACT

TORQUE VALUES

Fastener Size	Class 8.8 Torque (ft-lbs)	Class 10.9 Torque (ft-lbs)
6mm	6-7	6-7
8mm	15-16	22-23
10mm	31-32	44-45
12mm	54-55	78-79
14mm	87-88	125-126

- x1** Driver/Left Tyger Kobra
- x1** Passenger/Right Tyger Kobra
- x2** Driver/Left Front & Rear Mounting Brackets [A]
- x2** Passenger/Right Front & Rear Mounting Brackets [C]
- x1** Driver/Left Center Mounting Bracket [B]
- x1** Passenger/Right Center Mounting Bracket [E]
- x2** Driver/Left Front & Rear Brackets [F]
- x2** Passenger/Right Front & Rear Brackets [G]
- x2** Center Support Brackets [D]
- x20** 8mm x 24mm x 2mm Flat Washers
- x16** 8mm x 16mm x 1.6mm Flat Washers
- x28** 8mm Nylon Lock Nuts
- x8** 8mm x 1.25mm x 25mm Hex Bolts
- x12** 8mm x 1.25mm x 25mm Hex Combo Bolts

Parts List

Top View

ATTENTION: Refer to **D** and **P** labelling on the side of the tubes to determine Driver and Passenger TYGER Kobra

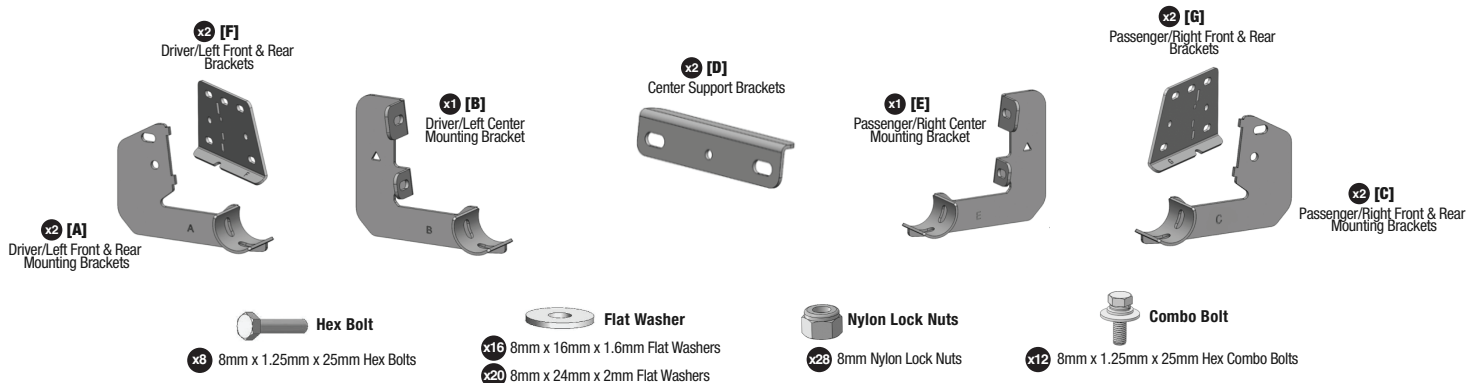
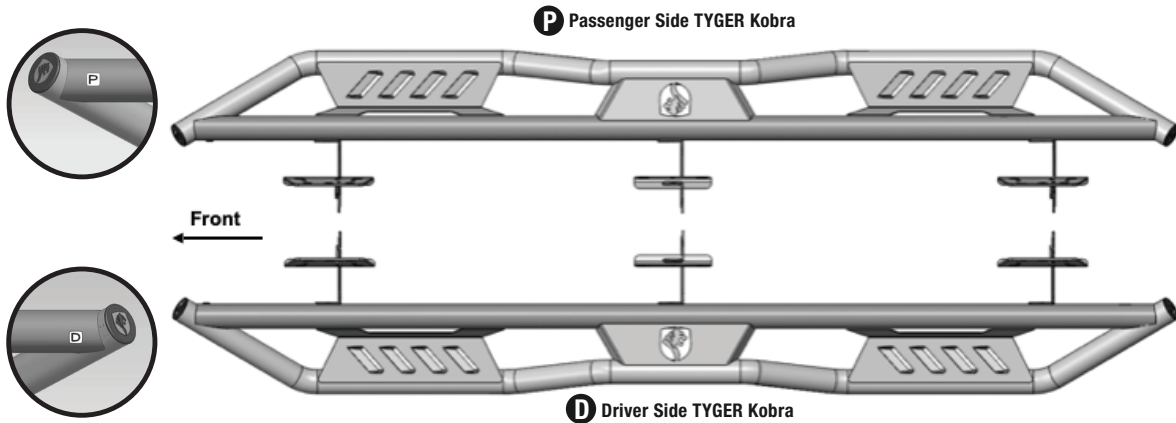

Reference the letters printed on the brackets to determine mounting locations

Top View

D Driver Side TYGER Kobra

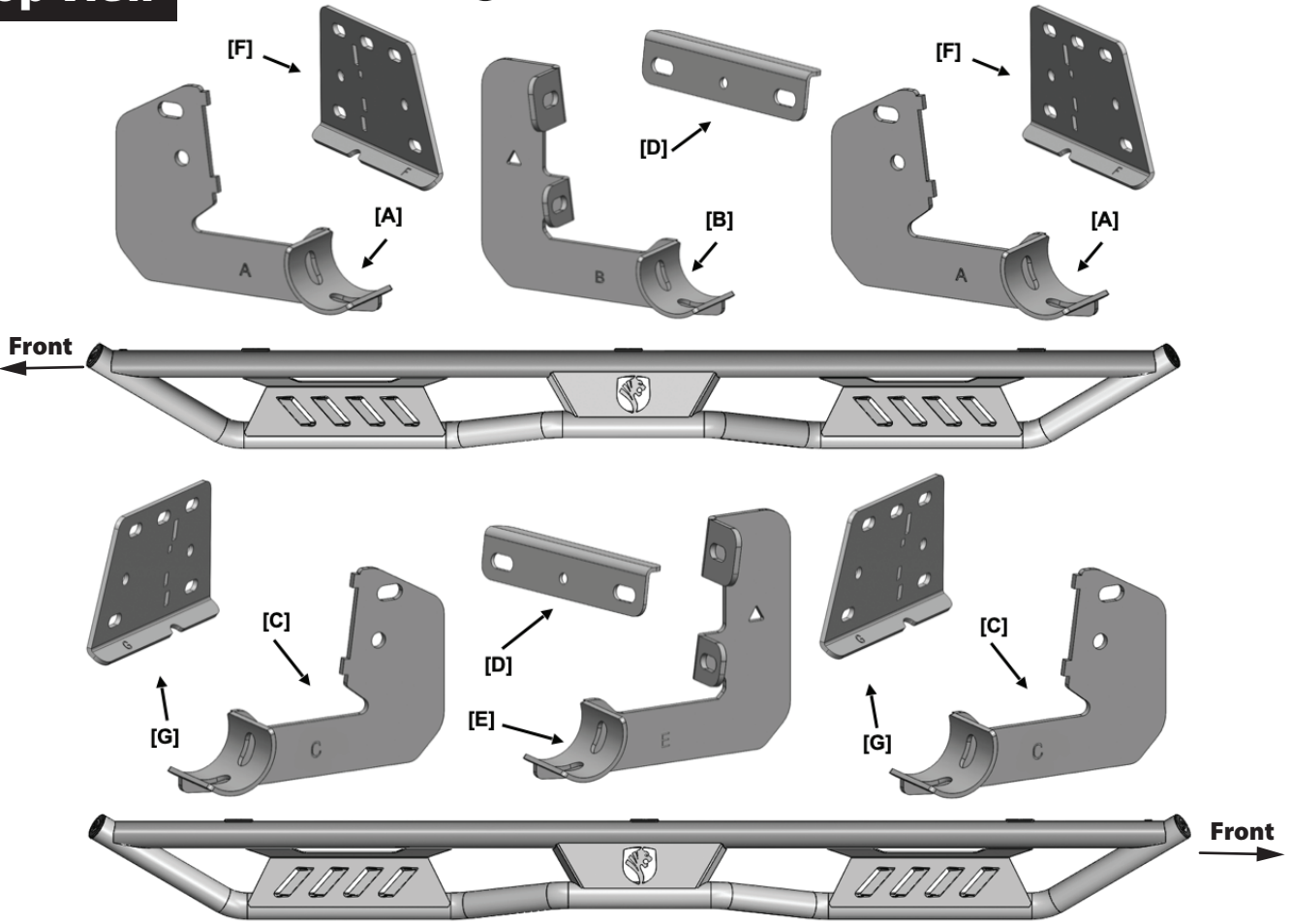

P Passenger Side TYGER Kobra

Bottom View

D Driver Side TYGER KOBRA

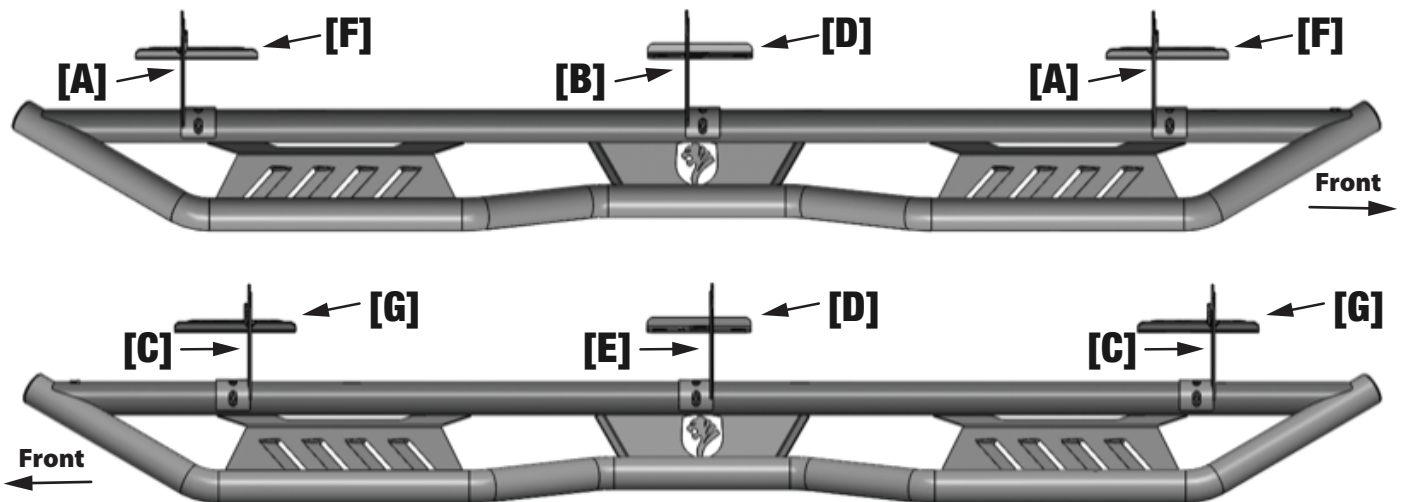

P Passenger Side TYGER KOBRA

TOOLS REQUIRED

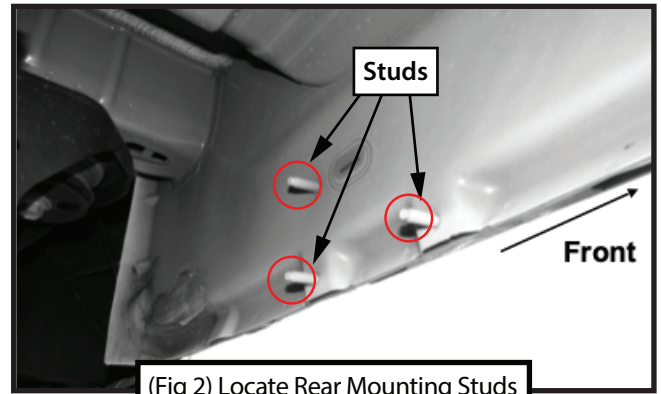
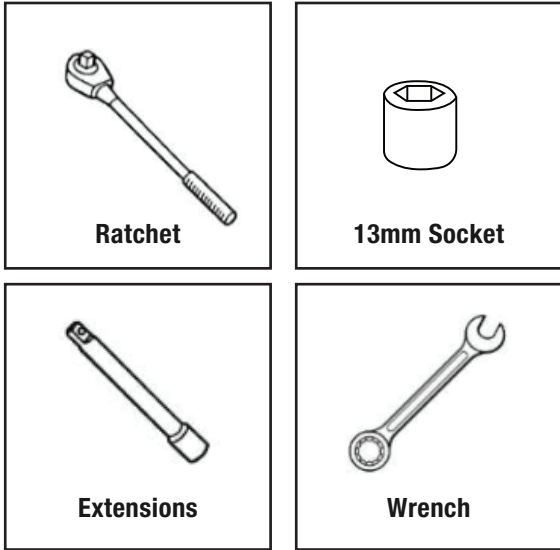

(Fig 2) Locate Rear Mounting Studs

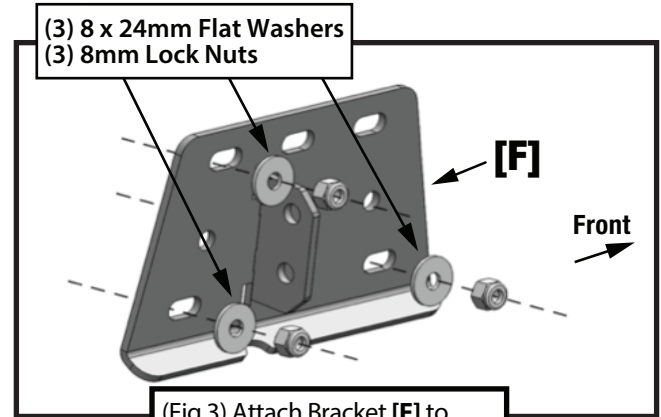

(Fig 3) Attach Bracket [F] to Front and Rear Mounting Studs

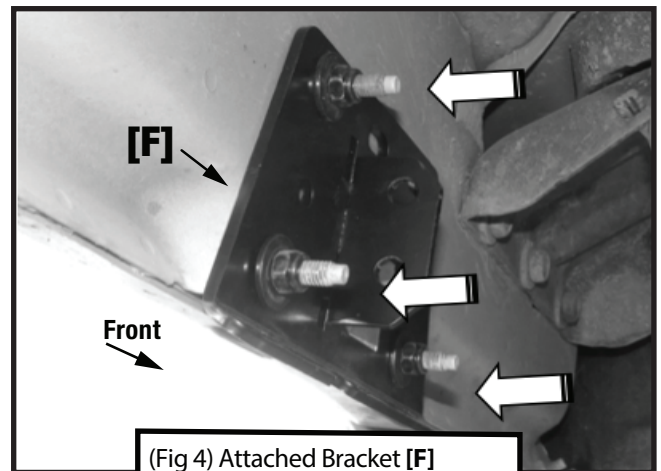

(Fig 4) Attached Bracket [F] attached to Front Mounting Studs

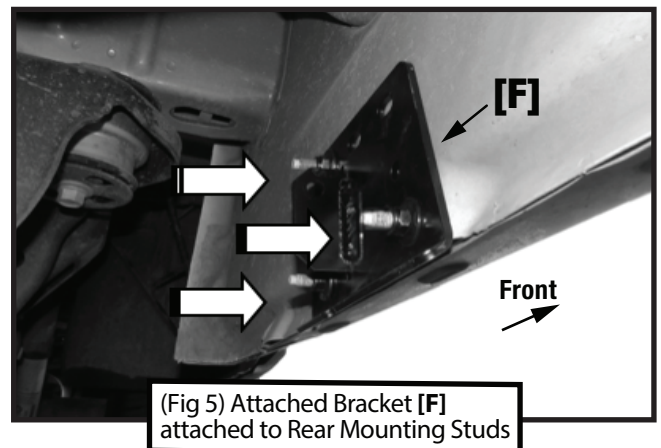

(Fig 5) Attached Bracket [F] attached to Rear Mounting Studs

STEP 1 MOUNTING BRACKETS

Follow (Fig 1 – 13) to attach the Mounting Brackets to the Driver/Left Side. Ensure hardware is hand tightened at this point.

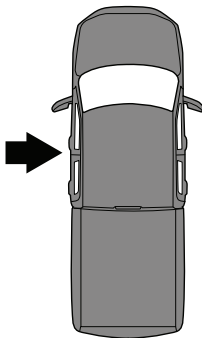

Driver-side Front & Rear Mounting Area

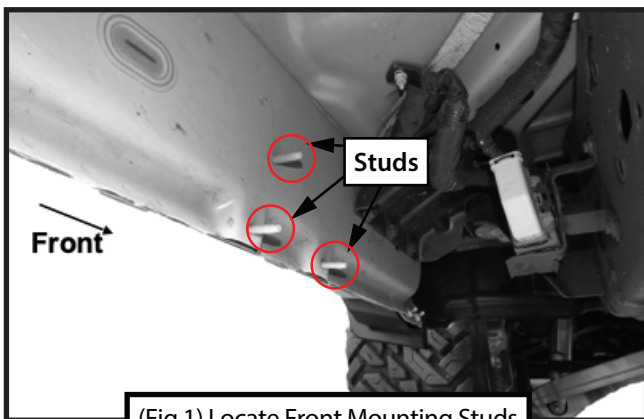

(Fig 1) Locate Front Mounting Studs

- (2) 8mm Hex Nuts
- (4) 8 x 16mm Flat Washers
- (2) 8mm Hex Bolts

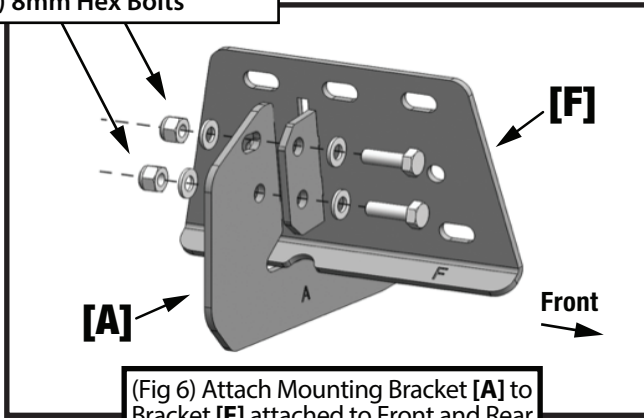

(Fig 6) Attach Mounting Bracket [A] to Bracket [F] attached to Front and Rear Mounting Studs

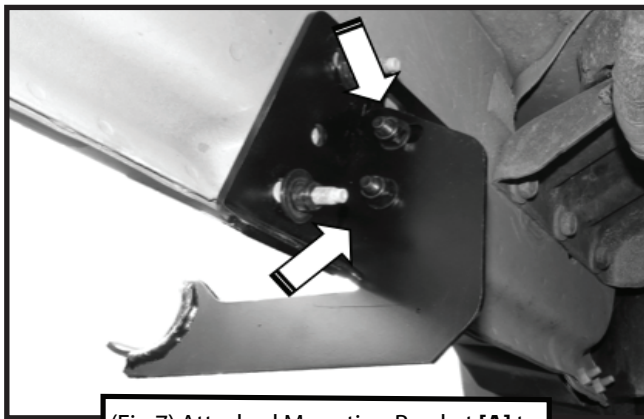

(Fig 7) Attached Mounting Bracket [A] to Bracket [F] at Front Mounting Studs

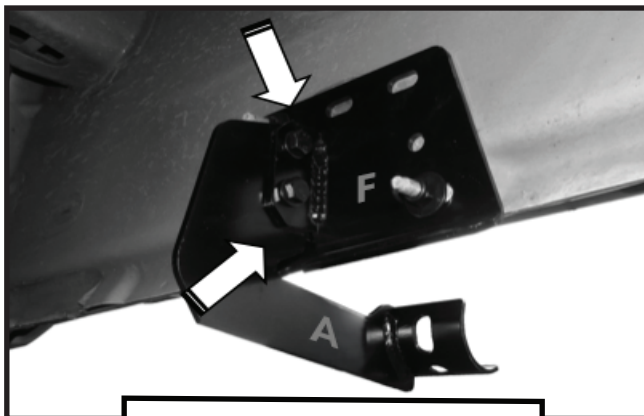

(Fig 8) Attached Mounting Bracket [A] to Bracket [F] at Rear Mounting Studs

Driver-side Center Mounting Area

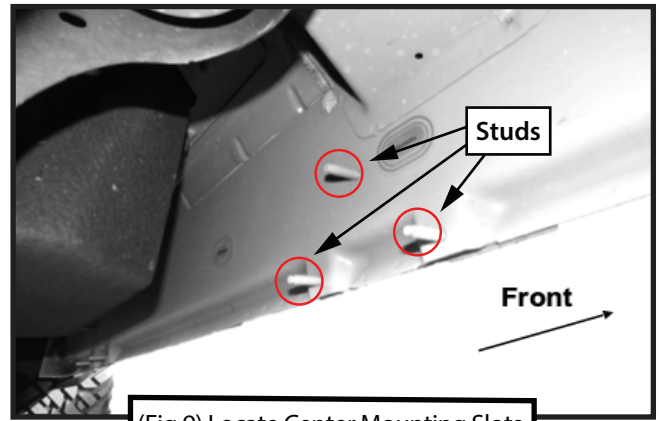

(Fig 9) Locate Center Mounting Slots

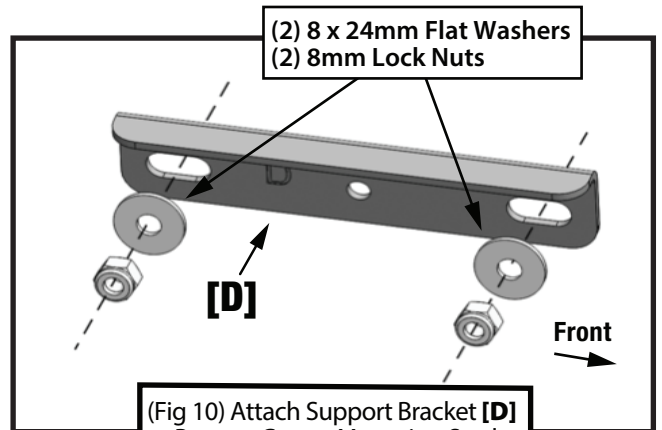

(Fig 10) Attach Support Bracket [D] to Bottom Center Mounting Studs

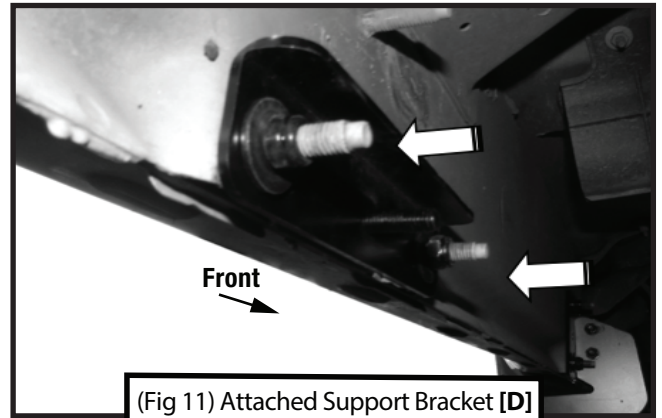

(Fig 11) Attached Support Bracket [D] to Bottom Center Mounting Studs

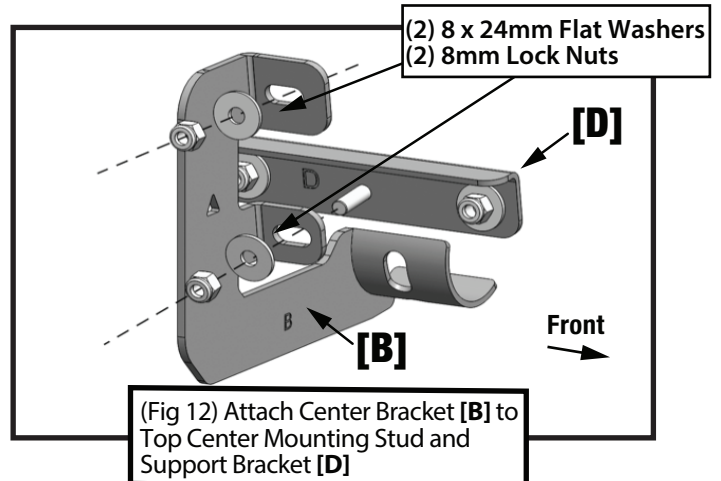

(Fig 12) Attach Center Bracket [B] to Top Center Mounting Stud and Support Bracket [D]

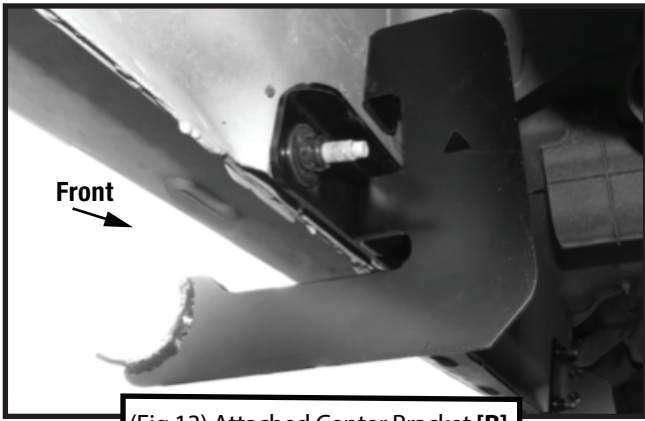

(Fig 13) Attached Center Bracket [B] with Support Bracket [D]

STEP 2 MOUNTING RUNNING BOARD

Follow (Fig 14 – 15) to install the Kobra Drop Step on the Driver/Left. Ensure all hardware is hand tightened at this point.

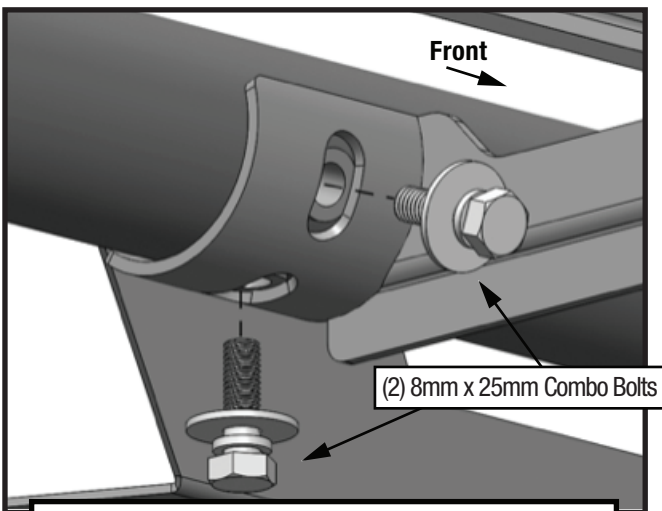

(Fig 14) Attach Kobra Drop Step to Mounting Brackets

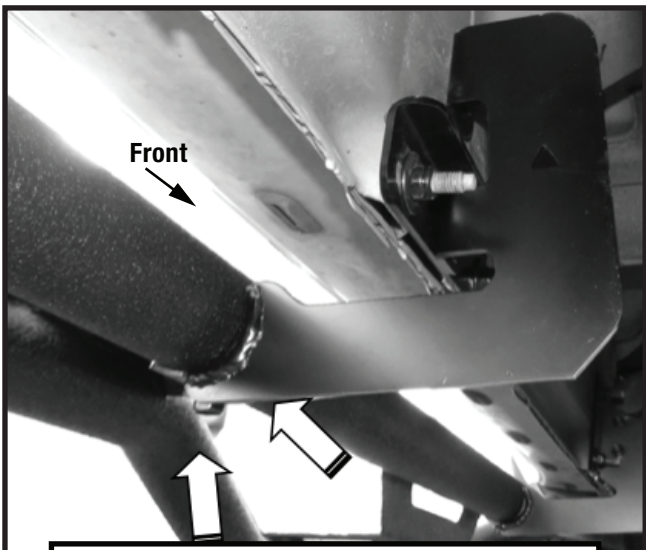

(Fig 15) Attached Drop Step to Mounting Brackets

STEP 3 PASSENGER SIDE

Repeat **STEPS 1-2** for passenger side installation. Use Front & Rear Mounting Brackets [C] instead of [A]; Use Front & Rear Support Brackets [G] instead of [F]; Use Center Mounting Bracket [E] instead of [B].

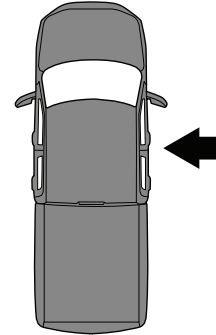

STEP 4 COMPLETION

Ensure Tyger Kobra Drop Step is level and straightened, then tighten all fasteners. Installation is complete. Perform periodic inspections to the installation to make sure that all hardware is secure and tight.

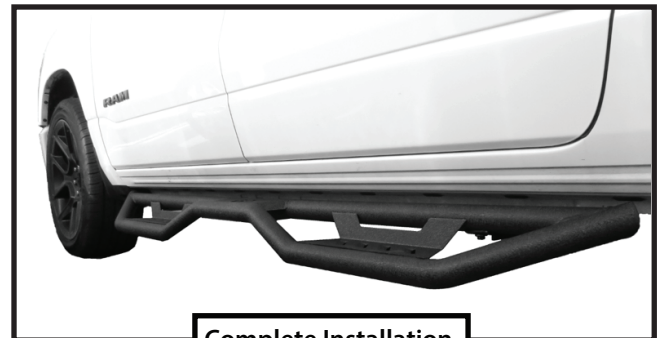

Complete Installation