



TYGER KOBRA

TG-KB2T25002

Scan to Download the Latest Digital Version



BEFORE INSTALLATION

READ INSTRUCTIONS CAREFULLY BEFORE STARTING INSTALLATION. REMOVE CONTENTS FROM BOX AND VERIFY ALL PARTS ARE PRESENT. FAILURE TO IDENTIFY DAMAGE BEFORE INSTALLATION COULD LEAD TO A REJECTION OF ANY CLAIM. IF MISSING PARTS OR ANY DAMAGE FOUND, PLEASE TAKE A PICTURE FOR THE CLAIM PURPOSE. TO FILE YOUR CLAIM, PLEASE VISIT: WWW.TYGERAUTO.COM/CONTACT

TORQUE VALUES

Fastener Size	Class 8.8 Torque (ft-lbs)	Class 10.9 Torque (ft-lbs)
6mm	6-7	6-7
8mm	15-16	22-23
10mm	31-32	44-45
12mm	54-55	78-79
14mm	87-88	125-126

- x1** Driver/Left Tyger Kobra
- x1** Passenger/Right Tyger Kobra
- x1** Driver/Left Front Mounting Bracket [A]
- x1** Passenger/Right Front Mounting Bracket [C]
- x2** Driver/Left Center/Rear Mounting Brackets [B]
- x2** Passenger/Right Rear Mounting Brackets [D]
- x12** 8mm Lock Washer
- x12** 8mm x 24mm x 2mm Flat Washer
- x12** 8-1.25mm x 30mm Hex Bolts
- x12** 8-1.25mm x 25mm Combination Bolt

Parts List

Top View

ATTENTION: Refer to **D** and **P** labelling on the side of the tubes to determine Driver and Passenger TYGER Kobra

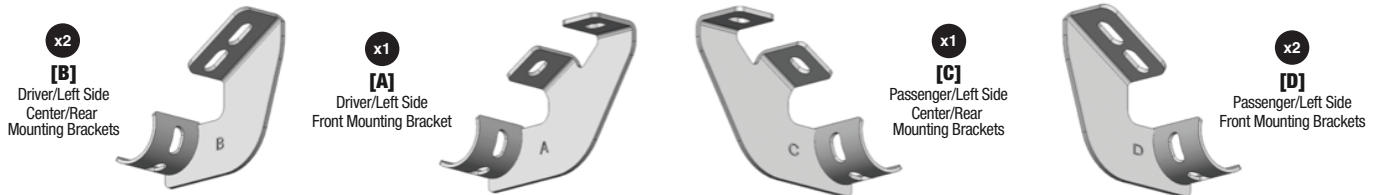
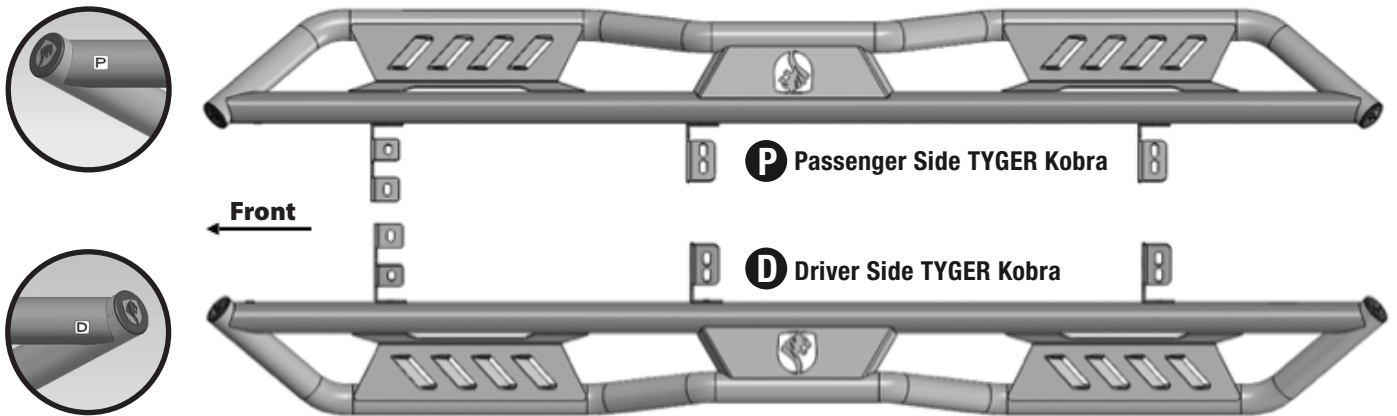

Reference the letters printed on the brackets to determine mounting locations

Top View

D Driver Side TYGER Kobra

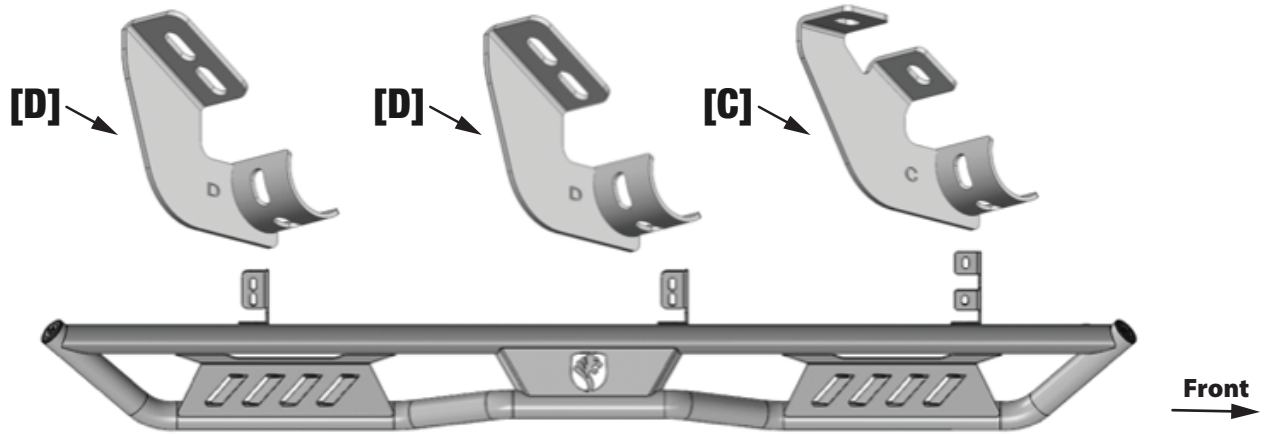
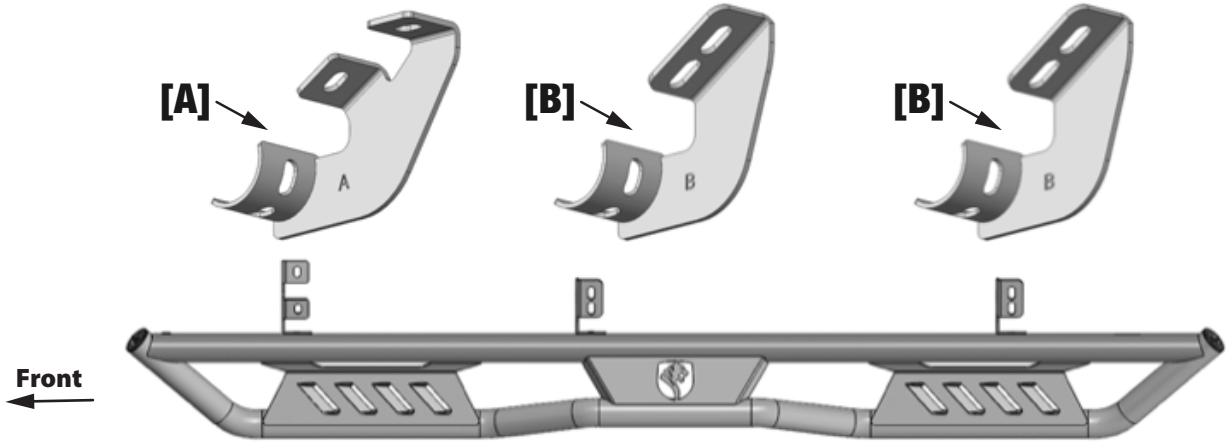

P Passenger Side TYGER Kobra

Bottom View

D Driver Side TYGER KOBRA

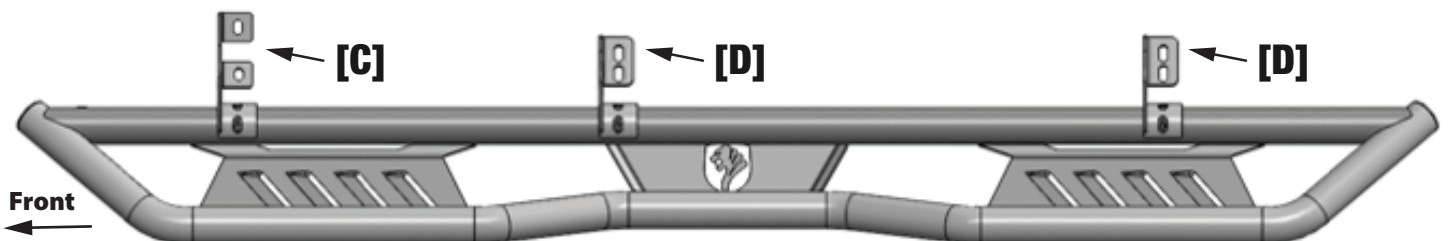
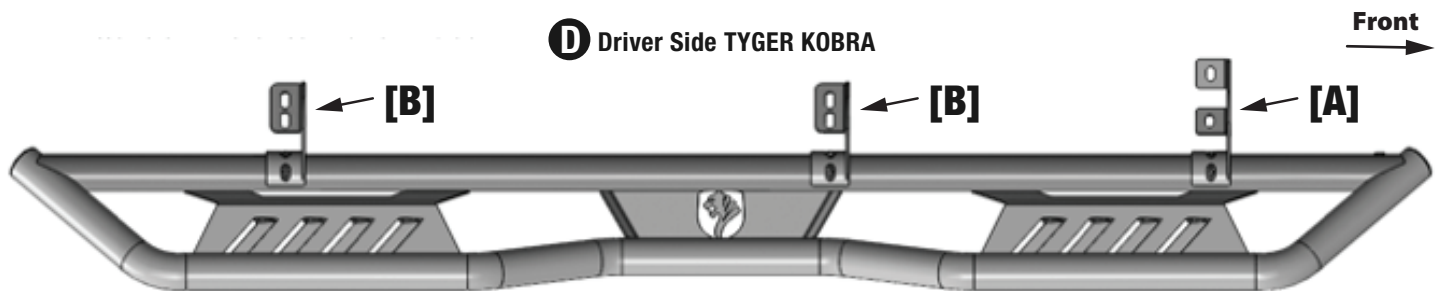

P Passenger Side TYGER KOBRA

TOOLS REQUIRED

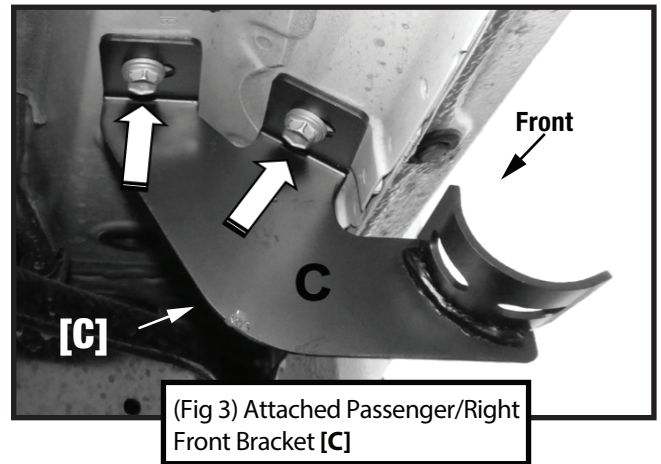
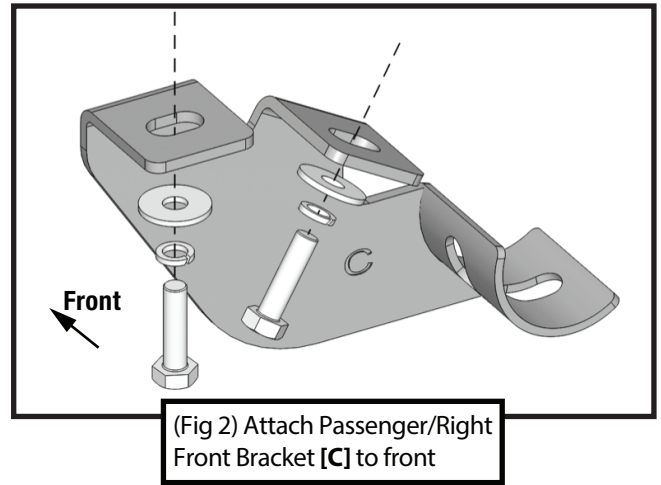
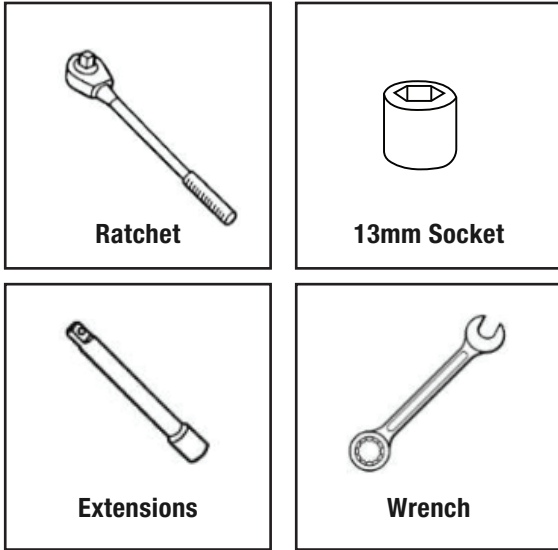

STEP 1 MOUNTING BRACKETS

Follow (Fig 1 – 9) to attach the brackets to the Passenger/Right Side. Ensure all hardware is hand tightened at this point.

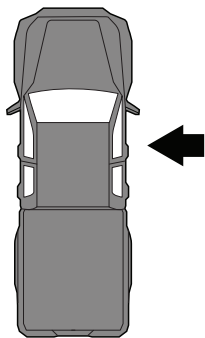

Passenger-side Front Mounting Area

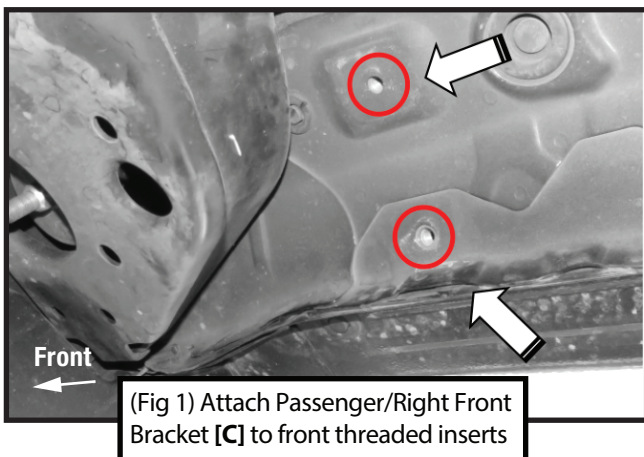

Passenger-side Center/Rear Mounting Area

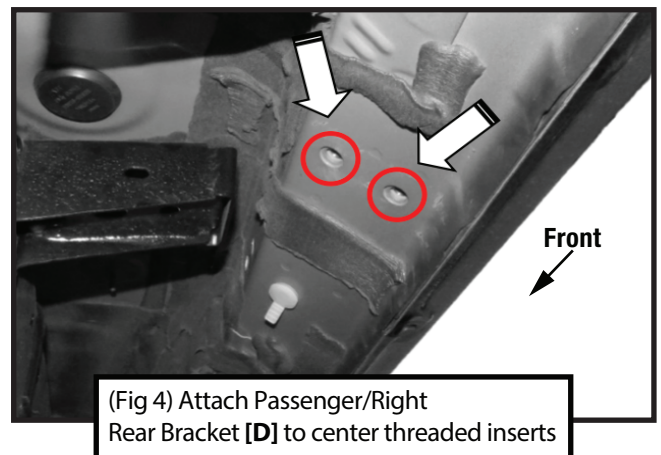

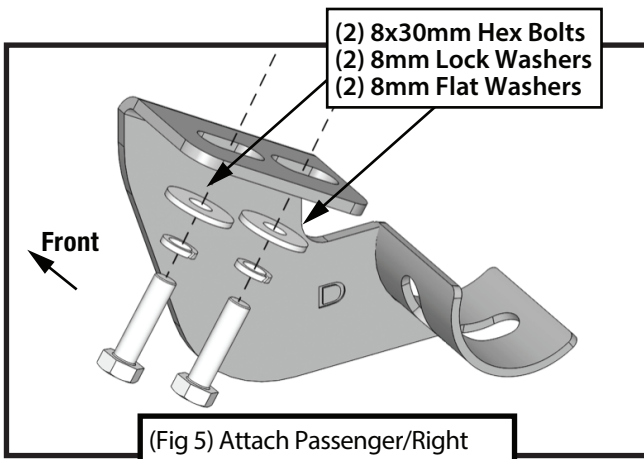

(Fig 5) Attach Passenger/Right Center/Rear Bracket [D] to center

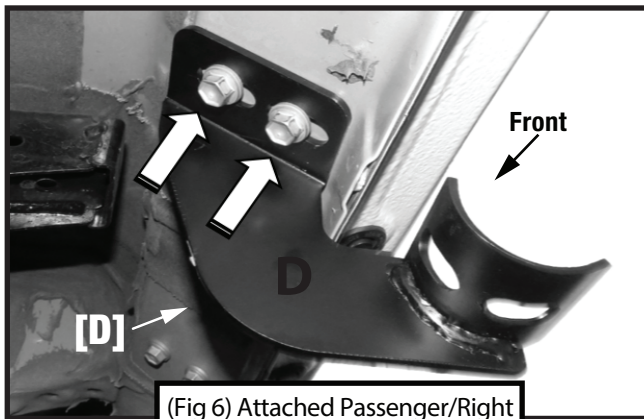

(Fig 6) Attached Passenger/Right Rear Bracket [D] to center

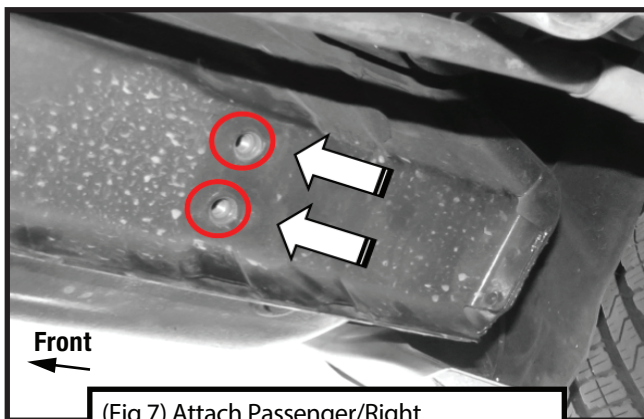

(Fig 7) Attach Passenger/Right Rear Bracket [D] to rear threaded inserts

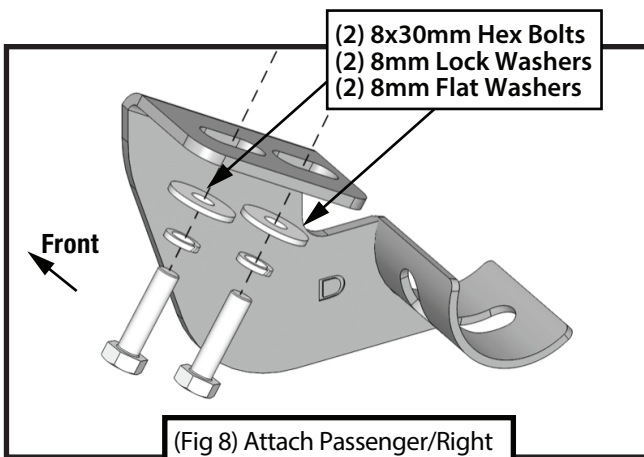

(Fig 8) Attach Passenger/Right Center/Rear Bracket [D] to rear

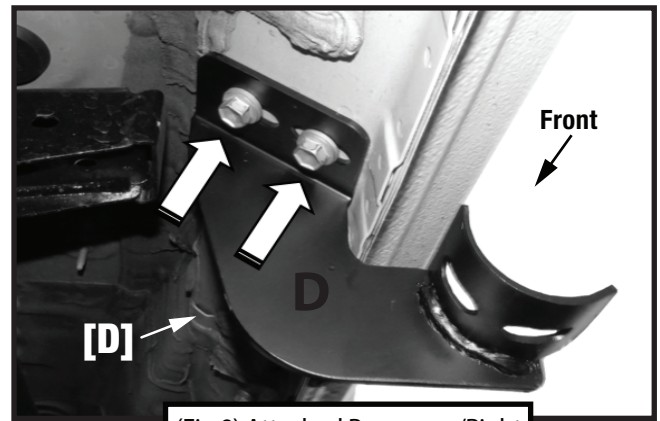

(Fig 9) Attached Passenger/Right Rear Bracket [D] to rear

STEP 2 MOUNTING RUNNING BOARD

Follow (Fig 10 – 11) to install the Kobra Drop Step on the Passenger/Right Mounting Brackets. Ensure all hardware is hand tightened at this point.

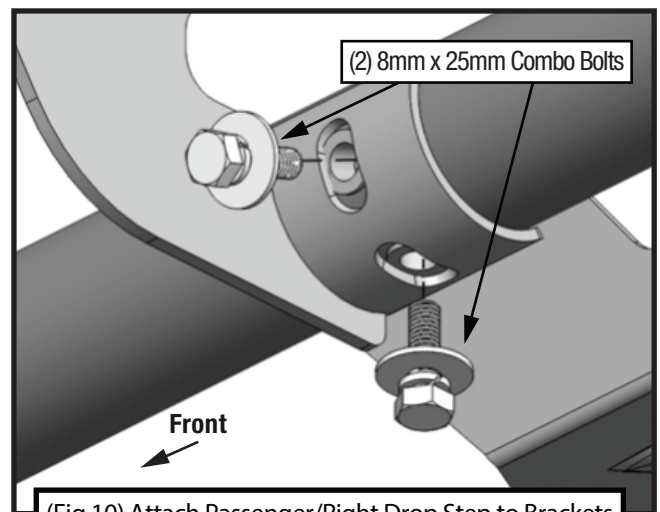

(Fig 10) Attach Passenger/Right Drop Step to Brackets

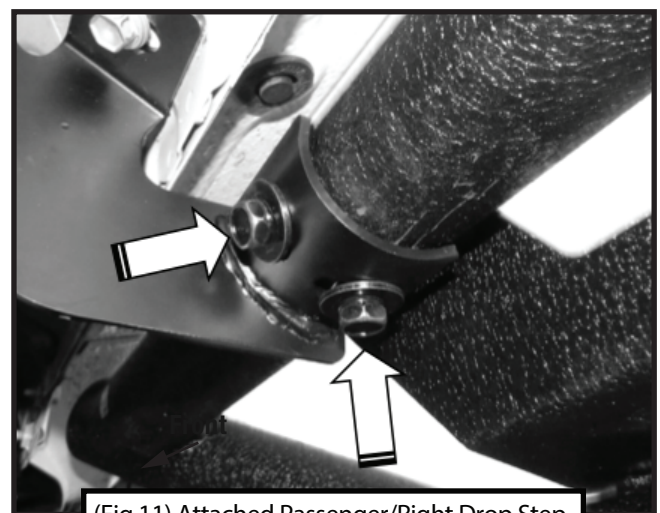

(Fig 11) Attached Passenger/Right Drop Step

STEP 3 DRIVER SIDE

Repeat **STEPS 1-2** for driver side installation.
 Use Front Mounting Bracket **[A]** instead of **[C]**;
 Use Center/Rear Mounting Bracket **[B]** instead of **[D]**.

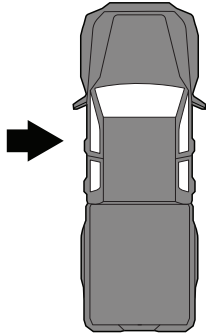

STEP 4

Ensure Tyger Kobra Drop Step is level and straightened, then tighten all fasteners. Installation is complete. Perform periodic inspections to the installation to make sure that all hardware is secure and tight.

