



TYGER LanderX

TG-LX3C82328

BEFORE INSTALLATION

READ INSTRUCTIONS CAREFULLY BEFORE STARTING INSTALLATION. REMOVE CONTENTS FROM BOX AND VERIFY ALL PARTS ARE PRESENT. FAILURE TO IDENTIFY DAMAGE BEFORE INSTALLATION COULD LEAD TO A REJECTION OF ANY CLAIM. IF MISSING PARTS OR ANY DAMAGE FOUND, PLEASE TAKE A PICTURE FOR THE CLAIM PURPOSE. TO FILE YOUR CLAIM, PLEASE VISIT: WWW.TYGERAUTO.COM/CONTACT

TORQUE VALUES

Fastener Size	Class 8.8 Torque (ft-lbs)	Class 10.9 Torque (ft-lbs)
6mm	6-7	6-7
8mm	15-16	22-23
10mm	31-32	44-45
12mm	54-55	78-79
14mm	87-88	125-126

- x1** Driver/Left TYGER LanderX
- x1** Passenger/Right TYGER LanderX
- x1** Passenger/Right Front Upper Support Bracket
- x1** Passenger/Right Front Lower Mounting Bracket
- x3** Passenger/Right Rear Mounting Brackets
- x4** Driver/Left Mounting Brackets
- x1** 8mm x 35mm Bolt Plate
- x17** 8mm Lock Washers
- x17** 8mm x 24mm x 2mm Flat Washers
- x1** 8mm x 28mm x 3mm Flat Washers
- x1** 8mm Nylon Lock Nuts
- x16** 8mm-1.25mm x 25mm Hex Bolts
- x1** 8mm-1.25mm x 40mm Hex BoltsRear Mounting Brackets
- x15** 8mm Clip-On Nuts
- x16** 8mm x 25mm Combo Hex Bolts

Parts List

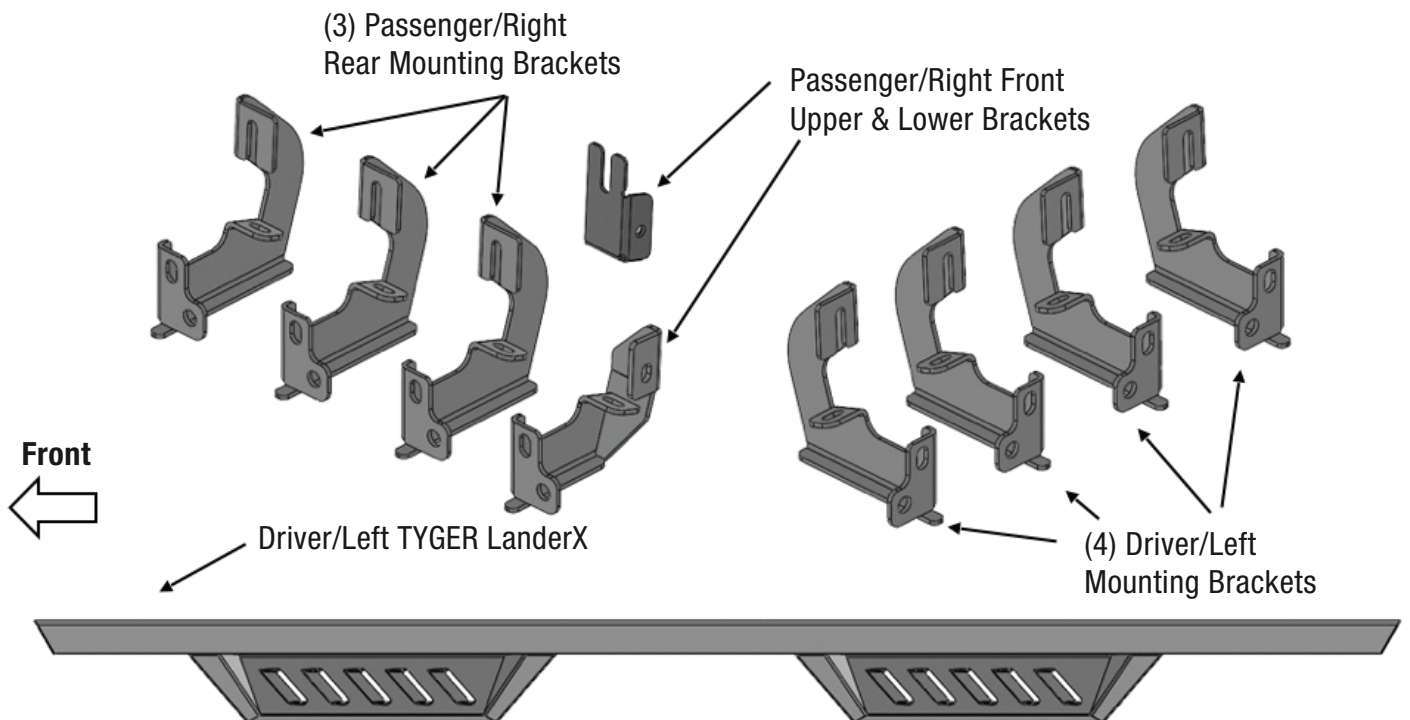

PROCEDURE:

REMOVE CONTENTS FROM BOX. VERIFY ALL PARTS ARE PRESENT. READ INSTRUCTIONS CAREFULLY BEFORE STARTING INSTALLATION. ON MODELS WITH DEF TANK, SELECT A FLAT, LEVEL AREA FOR INSTALLATION. MAY REQUIRE CUTTING.

STEP 1

Start the installation under the driver/left side of the vehicle. Locate the **5** tabs along the bottom edge of the body, (pinch weld). Mounting Brackets will bolt to the **1st, 2nd, 4th and 5th** mounting tabs (Fig 1). Directly above each tab is a top mounting location on the side of the rocker panel. Hold a Bracket up in place to help determine the mounting holes to use.

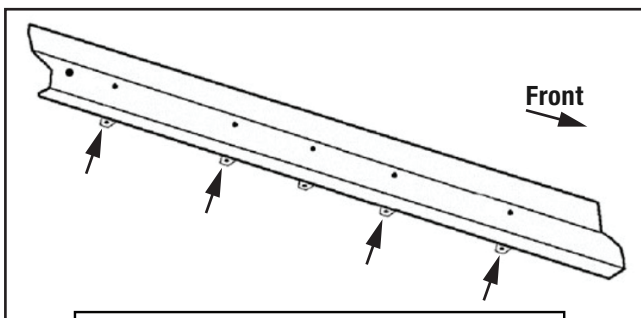

(Fig 1) Driver/Left (4) mounting locations

STEP 2

Determine the correct procedure for your model year and each Bracket location.

Bottom mounting location on the edge of the pinch weld.
Flat tab on pinch weld with factory installed weld nut:

Thread hex bolt into weld nut from the backside-down to clear paint from threads.

Flat tab on pinch weld with hole:

Select (1) 8mm Clip Nut. Slide the Clip Nut over the tab with the nut facing up behind the tab (Figs 2 & 3). Line up threaded nut with hole in the tab. Repeat for each mounting location.

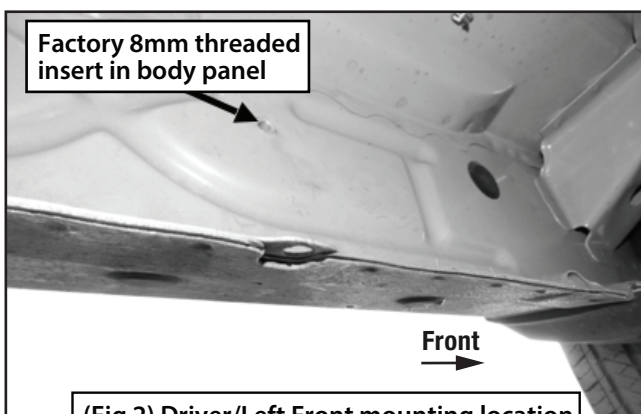

(Fig 2) Driver/Left Front mounting location

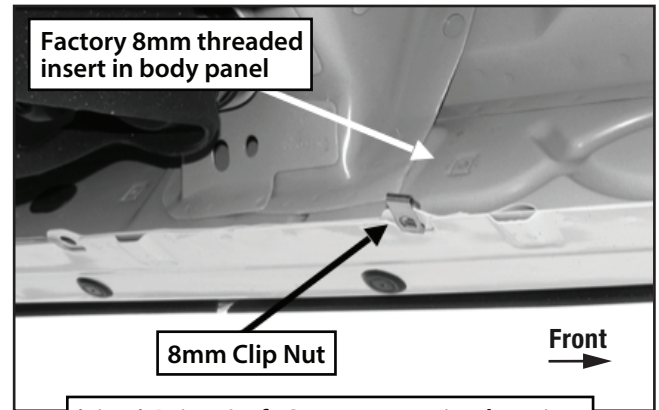

(Fig 3) Driver/Left Center mounting location

Locate top mounting location on the back side of the rocker panel.
Models with factory installed threaded insert in rocker panel:

Thread 8mm Hex Bolt into threaded insert to clear paint as required (Figs 2 & 3).

Large and small hole in side of body panel:

Remove the rubber plug from the larger hole (Fig 4). Select (1) 8mm Clip Nut. Slide the Clip Nut into the larger hole. Line up the threaded nut with the smaller hole.

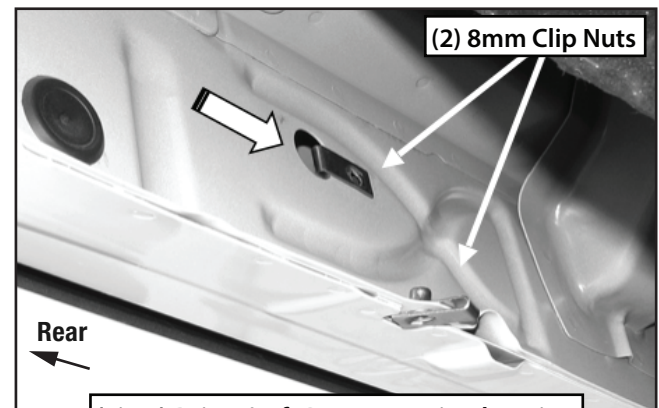

(Fig 4) Driver/Left Rear mounting location

STEP 3

Select (1) Driver/Left Mounting Bracket. Attach the Mounting Bracket to the Clip Nuts and/or the factory threaded holes with (2) 8mm x 25mm Hex Bolts, (2) 8mm Lock Washers and (2) 8mm x 24mm Flat Washers (Fig 5). **DO NOT** tighten hardware.

Driver/Left Side Installation Pictured

- (2) 8mm x 25mm Hex Bolts
- (2) 8mm Lock Washers
- (2) 8mm x 24mm Flat Washers
- (2) 8mm Clip Nuts

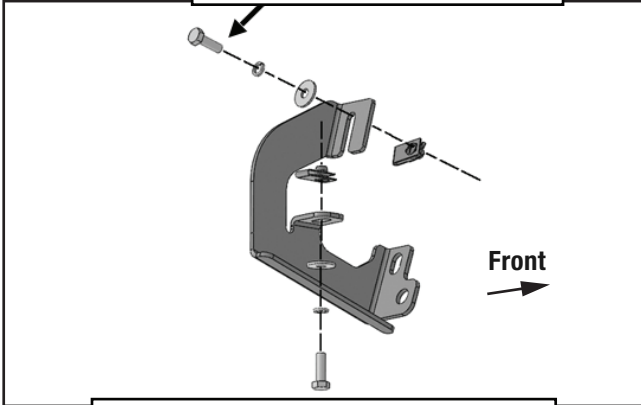

(Fig 5) Attach (1) Mounting Bracket to the Driver/Left front mounting location

STEP 4

Repeat **STEPS 1-3** to attach remaining (3) Driver/Left Mounting Brackets to the Driver/Left side.

STEP 5

Select the Driver/Left TYGER LanderX. Attach the Step to the Mounting Brackets with (8) 8mm Combo Bolts (Fig 6). **DO NOT** tighten hardware.

Driver/Left Side Installation Pictured

- (2) 8mm Combo Bolts

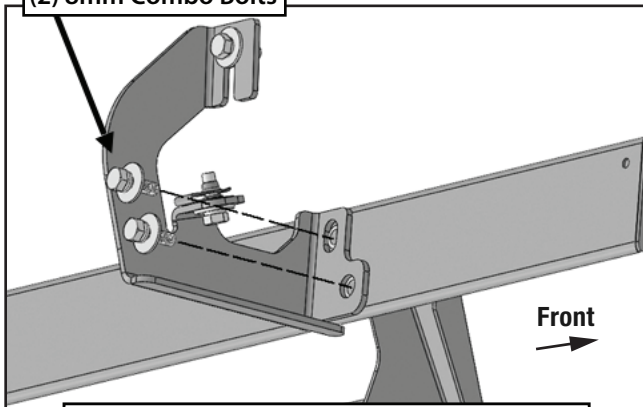

(Fig 6) Attach the Driver/Left TYGER LanderX to the Mounting Brackets

STEP 6

Move to the passenger/right side of the vehicle. Determine if the vehicle is equipped with a plastic diesel exhaust fluid (DEF) tank (Figs 7 & 8).

Models without DEF tank, skip to STEP 7.

Models with DEF tank: The tank sits close to the side of the body. With specialized tools, the Passenger/Right Front Upper and Lower Mounting Brackets can be installed but room is very limited. Determine model year of vehicle before proceeding.

Passenger/Right Front Installation Pictured

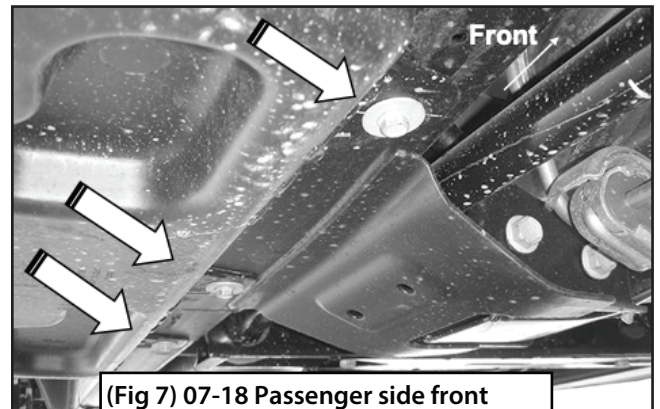

(Fig 7) 07-18 Passenger side front pictured with DEF tank cover. Remove (3) hex bolts to remove cover

- Remove (2) factory bolts to remove tank straps

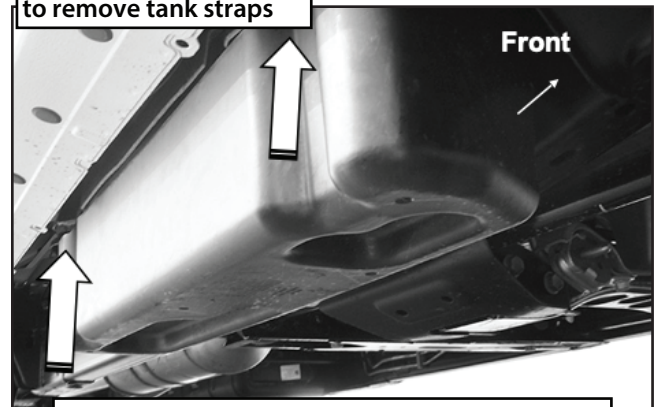

(Fig 8) 07-18 Passenger side DEF tank and cover

Up to 2016 models:

It may be easier to drop the tank down to access the inner side of the body panel for upper bracket installation. Tank will not need to be removed, only dropped down for access to mounting location. **IMPORTANT:** If tank is full, it will be very heavy and assistance is highly recommended to avoid injury or damage to the vehicle or the tank. It is recommended that installation is performed when the DEF tank is low on fluid before dropping the tank.

- a. On models with plastic lower tray under the tank, remove the (3) hex bolts attaching the tray to the frame (Fig 7), and remove the tray.
- b. Release the tank filler hose. Release the plug for the sending unit on the top of the tank.
- c. Support the tank with a floor jack. Place a smooth flat surface, (wooden block for example), between the floor jack and the tank to avoid damaging the plastic tank. DO NOT push up on the tank; only support the weight of the tank with the jack.
- d. Remove the (2) bolts securing the tank straps to the vehicle (Fig 8). Tilt the straps to release from the brackets. Slowly lower the tank until the top of the tank is almost visible. Use blocks or stands to support the tank while installing the Front Upper and Lower Brackets.
- e. Proceed to **STEP 7**.

On 2017 models and on:

- a. If necessary, remove the (4) hex bolts attaching plastic cover to DEF tank (Fig 9) and remove plastic cover for better access. **NOTE: On 2017-on 2500/3500 models**, only remove plastic cover from DEF tank. Do not lower DEF tank and proceed to **STEP 7**.

Passenger/Right Front Installation Pictured

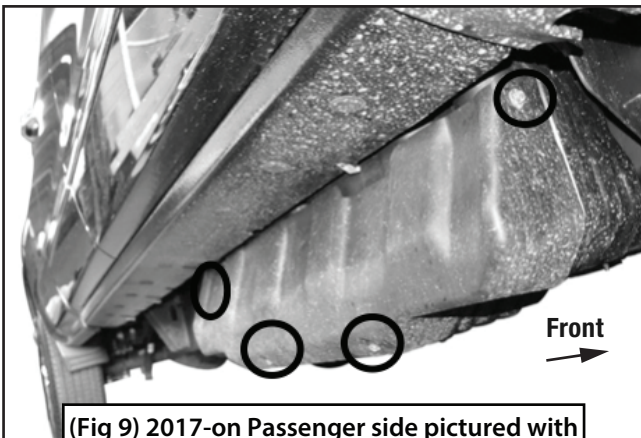

(Fig 9) 2017-on Passenger side pictured with DEF plastic tank cover. If needed, remove (4) hex bolts to remove plastic cover.

STEP 7

Locate the first tab on the edge of the pinch weld. Select the Upper Bracket (Fig 10). Repeat **STEPS 2 & 3** to attach the Passenger/Right Front Upper Mounting Bracket to the side of the rocker panel (Fig 10). DO NOT tighten hardware.

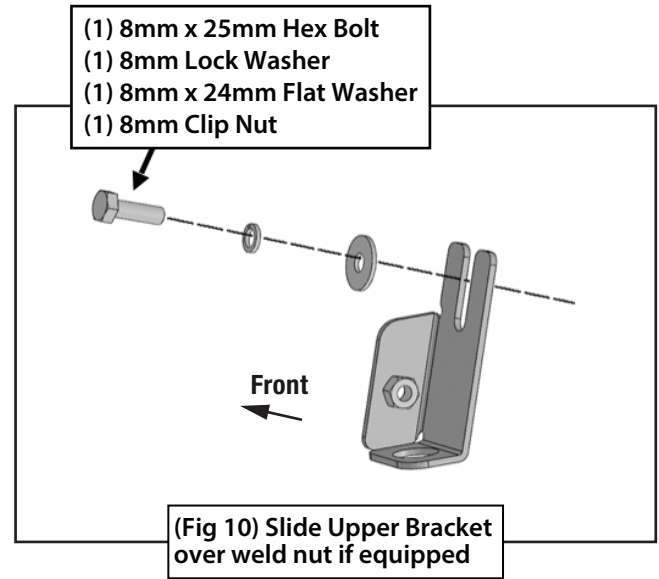

STEP 8

Line up the hole in the bottom of the Upper Bracket with the hole in the tab on the pinch weld.

- a. **Models with a weld-nut:** Slide the Bracket over the weld-nut. Attach the Lower Bracket to the bottom of the body and weld-nut with (1) 8mm x40mm Hex Bolt, (1) 8mm Lock Washer, (1) 8mm x 28mm Flat Washer, (1) 8mm x 24mm Flat Washer and (1) 8mm Nylon Lock Nut (Fig 12). DO NOT tighten hardware.

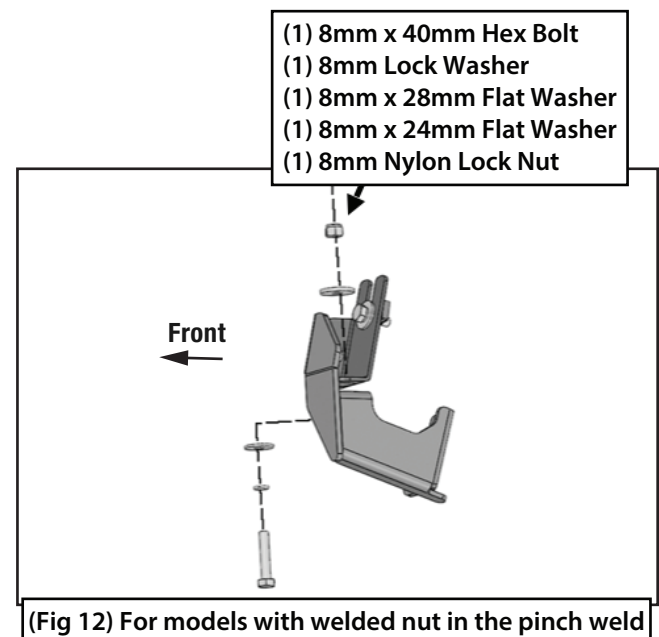

b. Models with flat tab and hole: Insert the 8mm Bolt Plate down through the hole in the Upper Bracket and tab. Attach the Lower Bracket to the bottom of the body and Bolt Plate with (1) 8mm x 28mm Flat Washer and (1) 8mm Nylon Lock Nut (Figs 12 & 13). **DO NOT** tighten hardware.

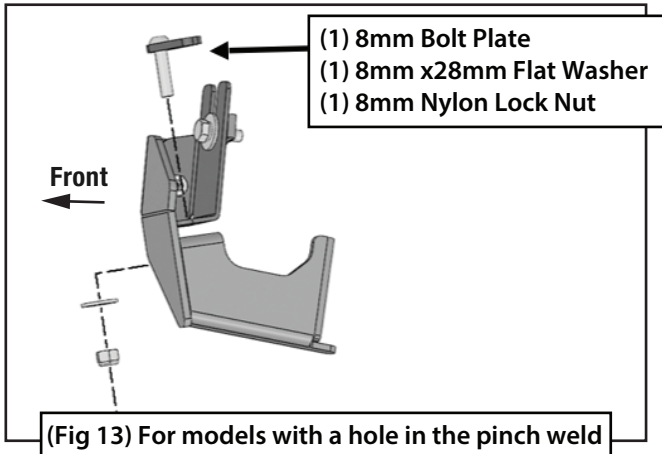
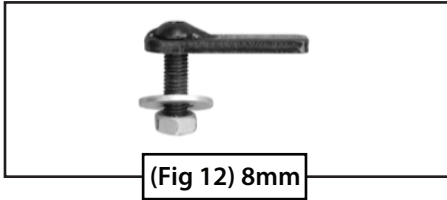

STEP 9

Secure the rear of the Lower Bracket to the Upper Bracket with (1) 8mm Hex Bolt, (1) 8mm Lock washer and (1) 8mm x 24mm Flat Washer (Fig 14). **DO NOT** tighten hardware.

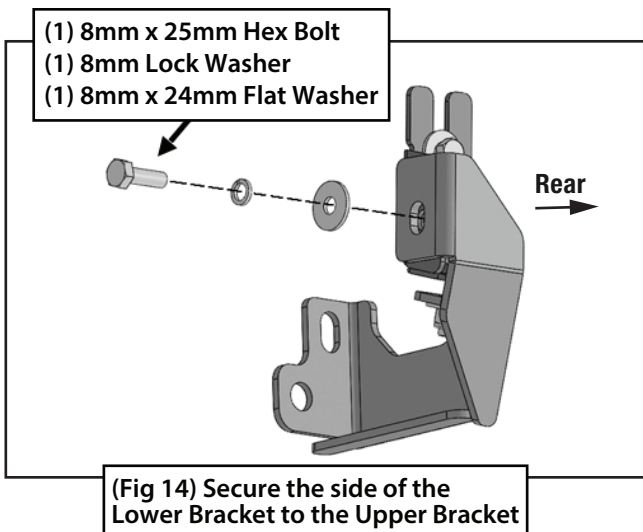

STEP 10

Repeat **STEPS 1-3** to attach the remaining (3) Passenger/Right Mounting Brackets to the passenger/right side rocker panel.

STEP 11

For 2017 2500/3500 DEF tank models: Locate the 2nd mounting location along the bottom edge of the body, (pinch weld) (Fig 1). Hold the DEF cover in place and mark the 2nd Bracket location onto the cover (Fig 15A). Use a sharp knife or hacksaw blade to carefully cut a slot in the plastic cover to clear the 2nd Bracket (Fig 15B). Remove as little plastic as possible.

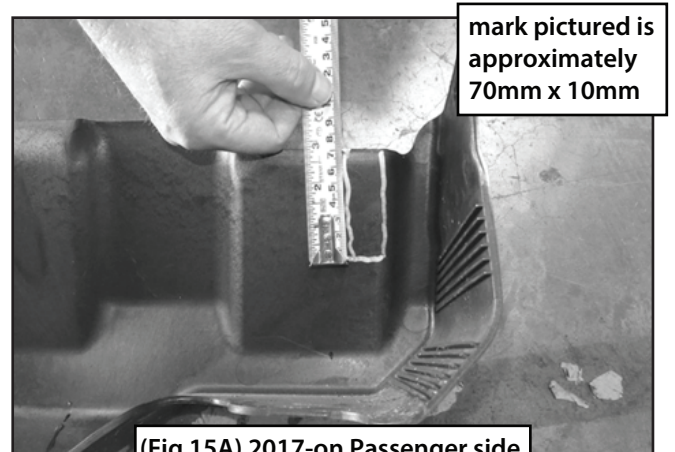

(Fig 15A) 2017-on Passenger side DEF cover marked for trimming

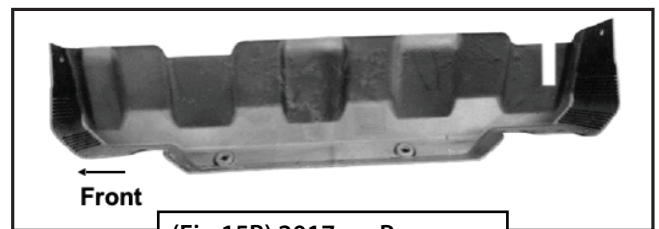

(Fig 15B) 2017-on Passenger DEF cut for example only

STEP 12

Repeat **STEP 5** to attach the Passenger/Right TYGER LanderX.

STEP 13

Once the Sidebar has been attached and all hardware fully tightened, reinstall the DEF tank and cover, if equipped, as described in **STEP 6**.

STEP 14

Do periodic inspections to the installation to make sure that all hardware is secure and tight.