



TYGER LanderX

TG-LX3C82438

BEFORE INSTALLATION

READ INSTRUCTIONS CAREFULLY BEFORE STARTING INSTALLATION. REMOVE CONTENTS FROM BOX AND VERIFY ALL PARTS ARE PRESENT. FAILURE TO IDENTIFY DAMAGE BEFORE INSTALLATION COULD LEAD TO A REJECTION OF ANY CLAIM. IF MISSING PARTS OR ANY DAMAGE FOUND, PLEASE TAKE A PICTURE FOR THE CLAIM PURPOSE. TO FILE YOUR CLAIM, PLEASE VISIT: WWW.TYGERAUTO.COM/CONTACT

TORQUE VALUES

Fastener Size	Class 8.8 Torque (ft-lbs)	Class 10.9 Torque (ft-lbs)
6mm	6-7	6-7
8mm	15-16	22-23
10mm	31-32	44-45
12mm	54-55	78-79
14mm	87-88	125-126

- x1** Driver/Left TYGER LanderX
- x1** Passenger/Right TYGER LanderX
- x3** Driver/Left Mounting Brackets (A)
- x1** Passenger/Right Front Upper Mounting Bracket (D)
- x1** Passenger/Right Front Lower Mounting Bracket (B)
- x2** Passenger/Right Center/Rear Mounting Brackets (C)
- x1** 8mm x 35mm Bolt Plate
- x11** 8mm Clip Nuts
- x12** 8-1.25mm x 25mm Combination Hex Bolts
- x1** 8-1.25mm x 40mm Hex Bolt
- x12** 8-1.25mm x 25mm Hex Bolts
- x1** 8mm x 28mm x 3mm Large Flat Washers
- x12** 8mm x 24mm x 2mm STD Flat Washers
- x13** 8mm Lock Washers
- x1** 8mm Nylon Lock Nut

Parts List

Reference the letters printed on the brackets to determine mounting locations

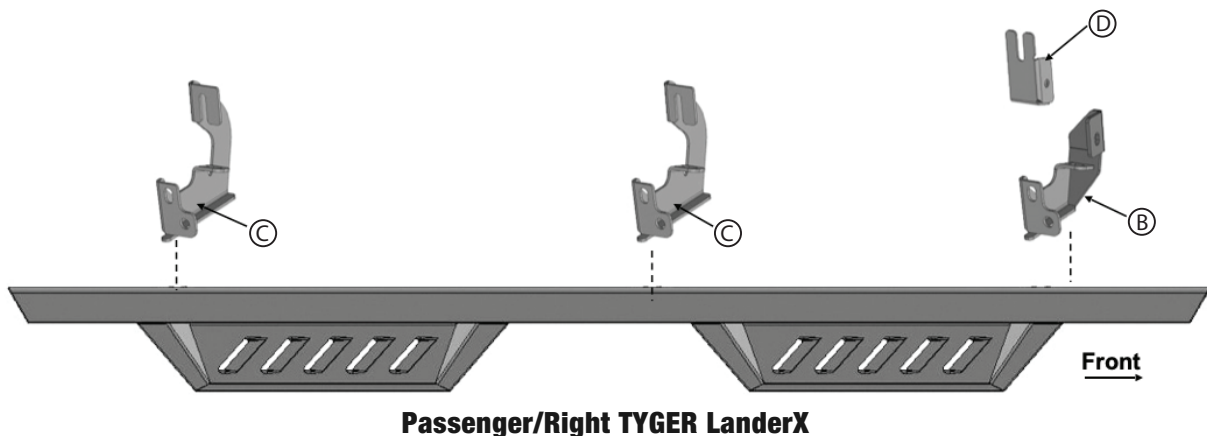
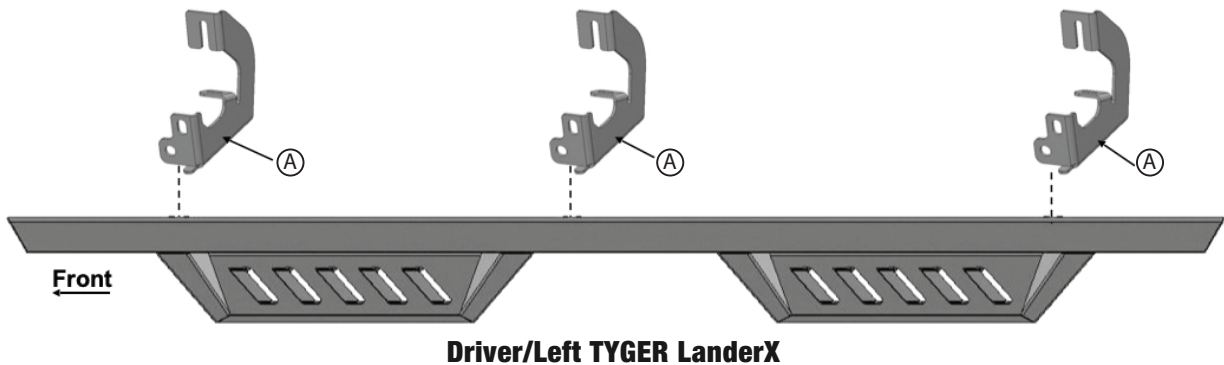

Bottom View

ATTENTION: Refer to the **D** or **P** labelling on the tubes to determine the Driver or Passenger side steps.

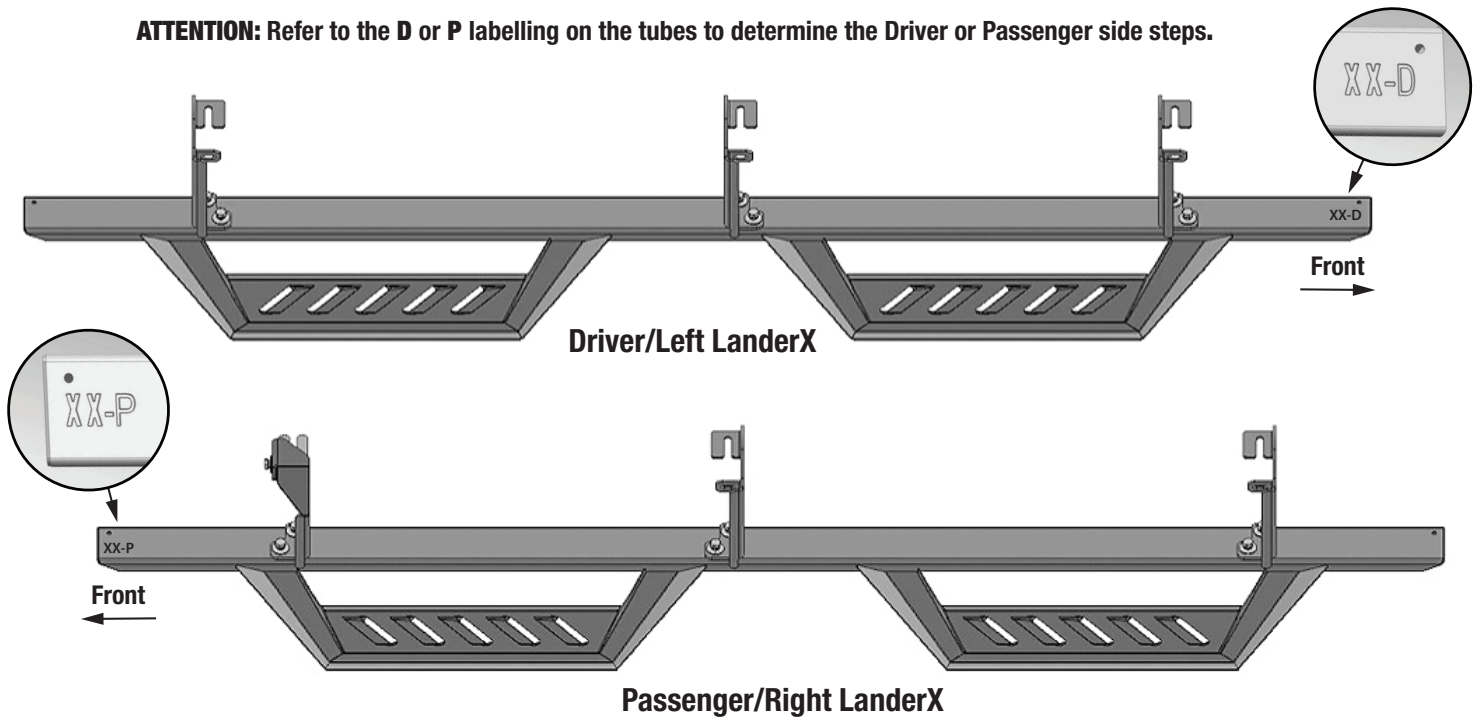

PROCEDURE:

REMOVE CONTENTS FROM BOX. VERIFY ALL PARTS ARE PRESENT. READ INSTRUCTIONS CAREFULLY BEFORE STARTING INSTALLATION. ASSISTANCE IS RECOMMENDED. ON MODELS WITH DEF TANK, SELECT A FLAT, LEVEL AREA FOR INSTALLATION. MAY REQUIRE CUTTING.

STEP 2

Determine the correct procedure for your model year and each Bracket location.

For the bottom mounting location on the edge of the pinch weld.

Flat tab on pinch weld with factory installed weld nut:

Thread hex bolt into weld nut from the backside-down to clear paint from threads (Fig 2).

Driver/Left Side Installation Pictured

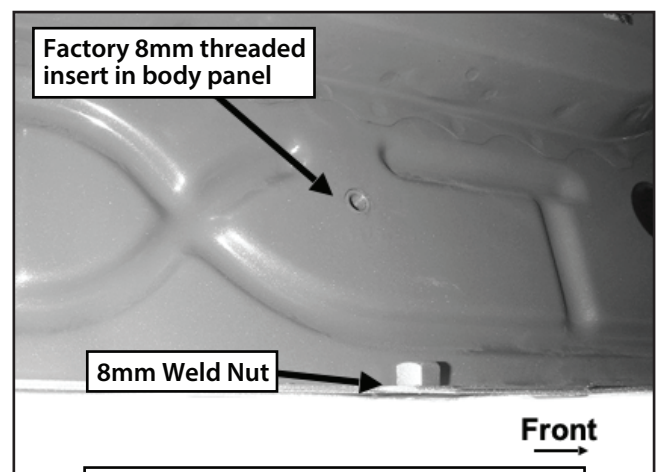

(Fig 2) Example driver/left side front mounting location with weld nut on pinch weld and threaded hole in body panel

Flat tab on pinch weld with hole only:

Select (1) 8mm Clip Nut. Slide the Clip Nut over the tab with the nut facing up behind the tab (Figs 3-5). Line up threaded nut with hole in tab. Repeat for each mounting location.

STEP 1

Start the installation under the driver/left side of the vehicle. Locate the 4 tabs along the bottom edge of the body, (pinch weld) (Fig 1).

IMPORTANT: Installation will use the front, second and rear mounting locations only. Directly above each tab is a top mounting location on the side of the body panel. Hold a Bracket up in place to help determine the mounting holes to use along the body.

Driver/Left Side Installation Pictured

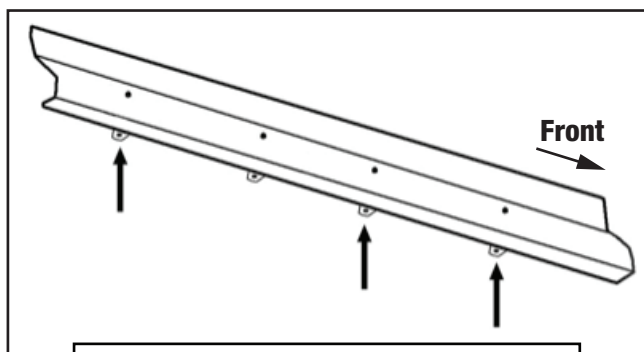

(Fig 1) Back of driver/left side (3) mounting locations along inner body panel

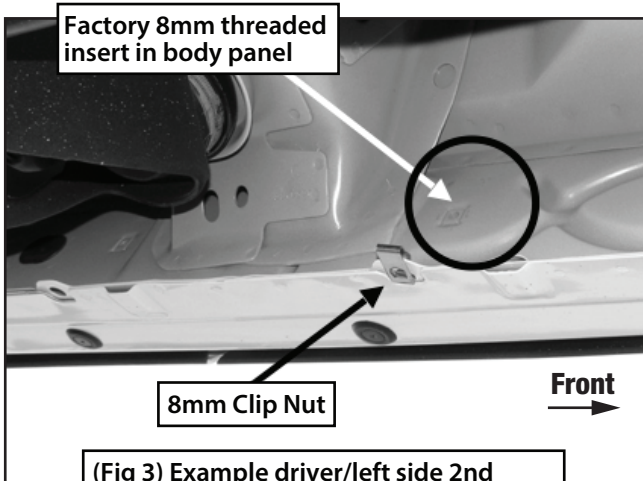

(Fig 3) Example driver/left side 2nd mounting location with threaded hole in body panel and flat tab on pinch weld

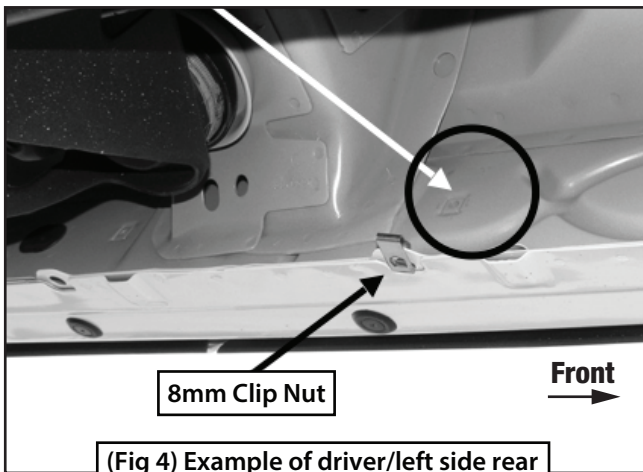

(Fig 4) Example of driver/left side rear mounting location with hole in body panel and flat tab on pinch weld

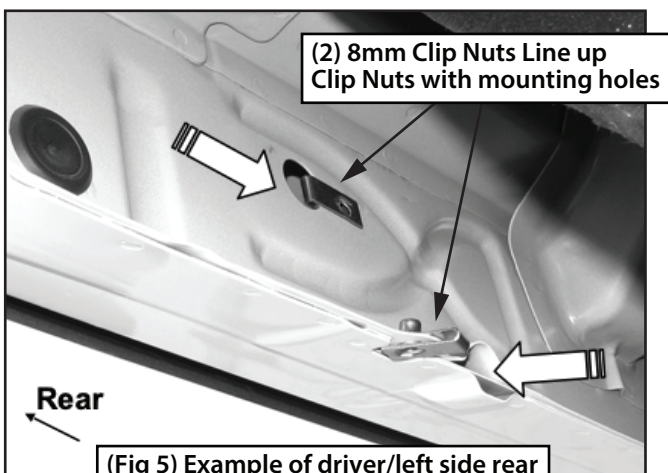

(Fig 5) Example of driver/left side rear mounting location with hole in body panel and flat tab on pinch weld

For the top mounting location on the side of the body panel.

Models with factory installed threaded insert in body panel:

Thread 8mm Hex Bolt into threaded insert to clear paint as required (Figs 2 & 3).

Large and small hole in side of body panel:

Remove the rubber plug from the larger hole (Fig 4). Select (1) 8mm Clip Nut. Slide the Clip Nut into the larger hole. Line up the threaded nut with the smaller hole (Fig 5)

STEP 3

Select (1) Driver/Left Mounting Bracket (A) (Fig 6). See illustration on page 1 to help determine correct Bracket. Attach the Bracket to the Clip Nuts and/or the factory threaded holes with (2) 8mm x 25mm Hex Bolts, (2) 8mm Lock Washers and (2) 8mm x 24mm STD Flat Washers (Figs 6 & 7). DO NOT fully tighten hardware at this time.

Driver/Left Side Installation Pictured

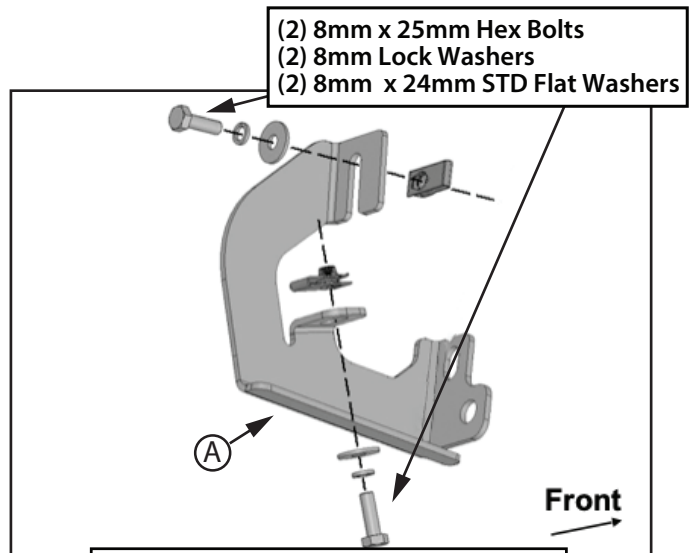

(Fig 6) Attach (1) Driver/Left Mounting Bracket (A) to the threaded holes or Clip Nuts in the front location

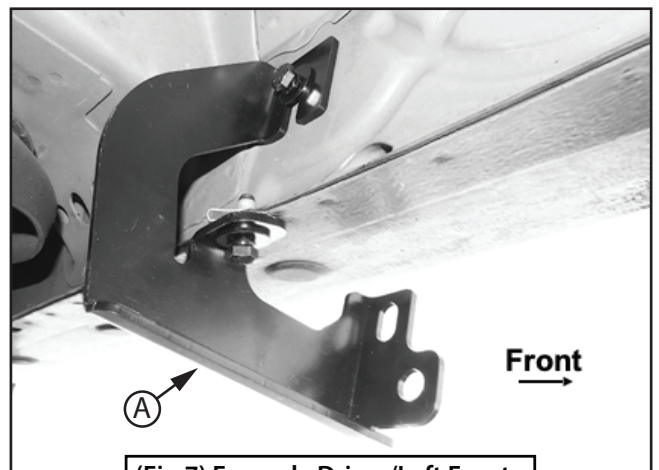

(Fig 7) Example Driver/Left Front Bracket (A) installed with Clip Nuts

STEP 4

Move to the center mounting location. Repeat **STEPS 1-3** to attach (1) Driver/Left Mounting Bracket (A) to the center mounting location (Figs 6 & 7).

STEP 5

Continue to the rear mounting location at the end of the cab. Repeat **STEPS 1-3** to attach the last (1) Driver/Left Mounting Bracket (A) to the last mounting location (Figs 6 & 7).

STEP 6

Carefully unwrap the Drop Steps. Select the Driver/Left TYGER LanderX. Note "D" on back of tube (Fig 8). Carefully position the TYGER LanderX up to the (3) Brackets. **IMPORTANT:** DO NOT slide, (front to back or rotate), the TYGER LanderX against the Brackets or damage to the finish may result. Attach the TYGER LanderX to the Brackets with (6) 8mm x 25mm Combo Hex Bolt assemblies (Figs 8-12). DO NOT fully tighten hardware.

Driver/Left Side Installation Pictured

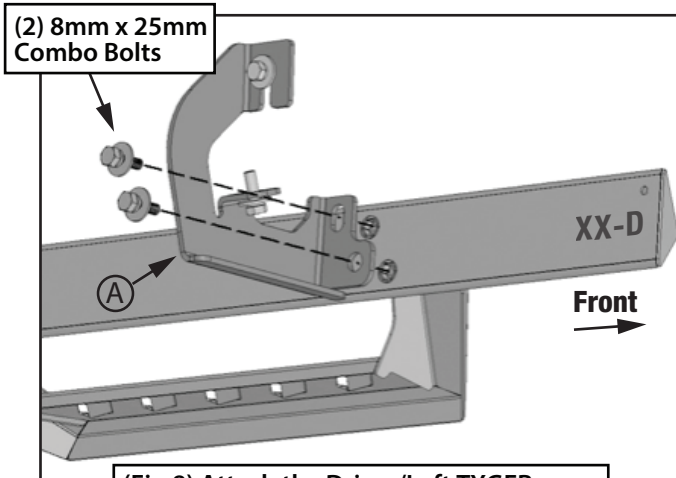

(Fig 8) Attach the Driver/Left TYGER LanderX to the Front Mounting Bracket (A)

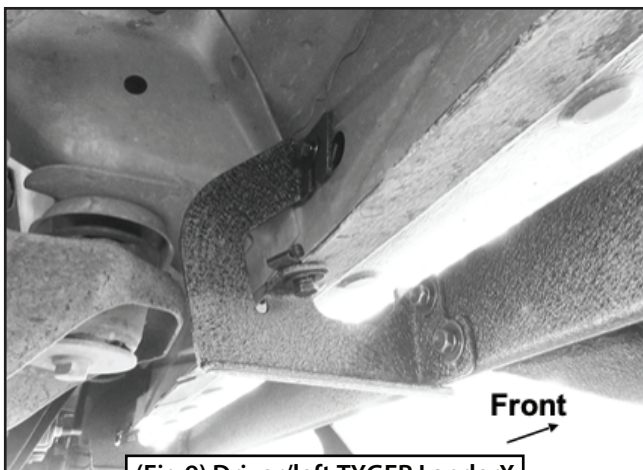

(Fig 9) Driver/left TYGER LanderX attached to Front Bracket (A)

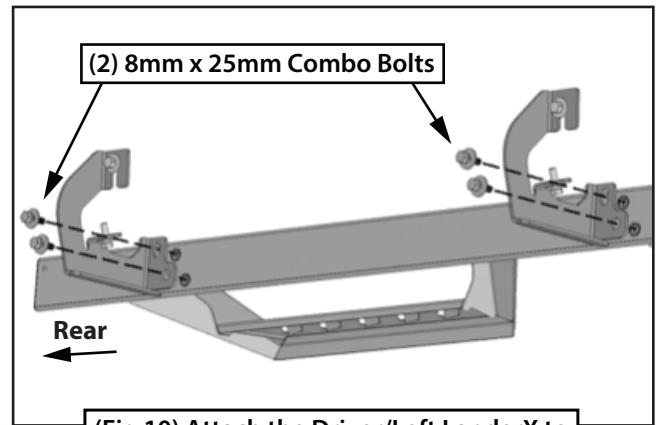

(Fig 10) Attach the Driver/Left LanderX to the center and rear Mounting Brackets

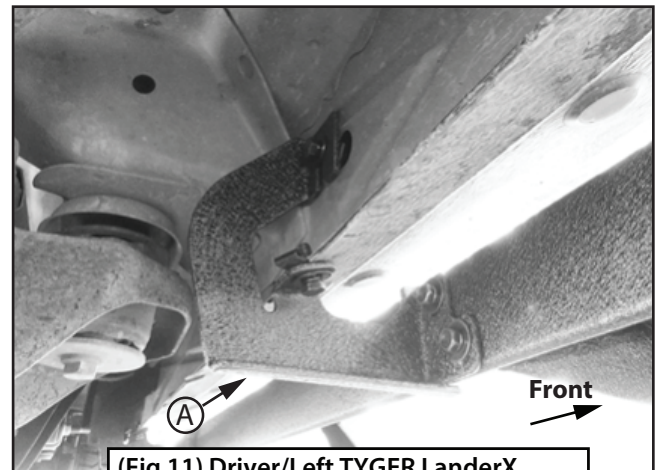

(Fig 11) Driver/Left TYGER LanderX attached to Center Mounting Bracket (A)

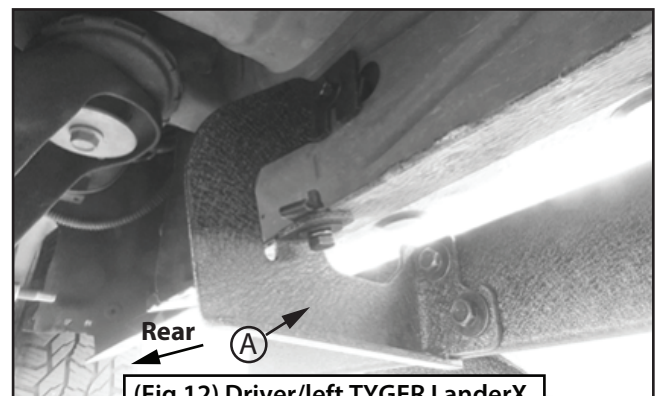

(Fig 12) Driver/left TYGER LanderX attached to rear Mounting Bracket

STEP 7

Level and adjust the TYGER LanderX and tighten all hardware.

STEP 8

Move to the passenger/right side of the vehicle. Determine if the vehicle is equipped with a plastic diesel exhaust fluid (DEF) tank (Figs 13 & 14).

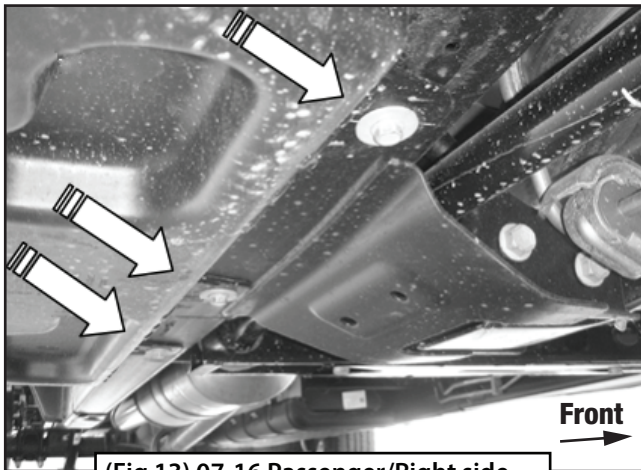
Passenger/Right Side Installation Pictured

(Fig 13) 07-16 Passenger/Right side front pictured with DEF tank cover. Remove (3) hex bolts to remove cover

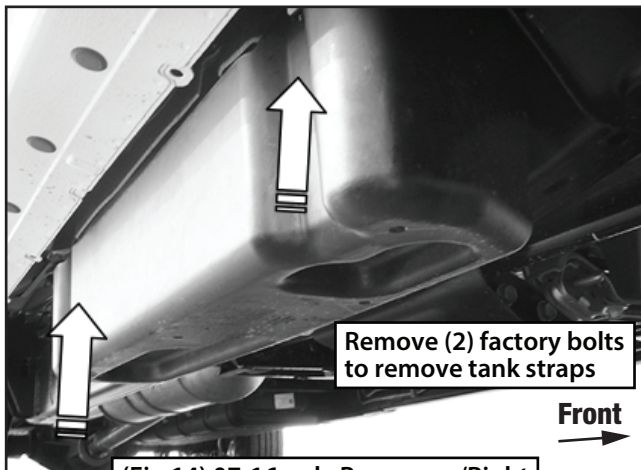

(Fig 14) 07-16 only Passenger/Right side DEF tank and cover

Models without DEF tank, skip to STEP 9.

2007-16 Models with DEF tank: The tank sits close to the side of the body. With specialized tools, the passenger/right front upper and lower Bracket can be installed but room is limited. It may be easier to drop the tank down to access the inner side of the body panel for upper bracket installation. Tank will not need to be removed, only dropped down for access to mounting location.

IMPORTANT: If tank is full, it will be very heavy, and assistance is highly recommended to avoid injury or damage to the vehicle or the tank. It is recommended that installation is performed when the DEF tank is low on fluid before dropping the tank.

- On 07-16 models with plastic lower tray under tank, remove the (3) hex bolts attaching the tray to the frame (Fig 13), and remove tray.
- Release the tank filler hose. Release the plug for the sending unit on the top of the tank.
- Support the tank with a floor jack. Place a smooth flat surface, (wooden block for example), between the floor jack and the tank to avoid damaging the plastic tank. DO NOT push up on the tank; only support the weight of the tank with the jack.

- Remove the (2) bolts securing the tank straps to the vehicle (Fig 14). Tilt the straps to release straps from the brackets. Slowly lower the tank until the top of the tank is almost visible. Use blocks or stands to support the tank while installing the front Upper Ⓧ and Lower Brackets Ⓧ.

- Proceed to **STEP 9**.

2017-on Models with DEF tank:

- Remove only the plastic cover from the tank, DO NOT remove tank (Figs 15 & 16).

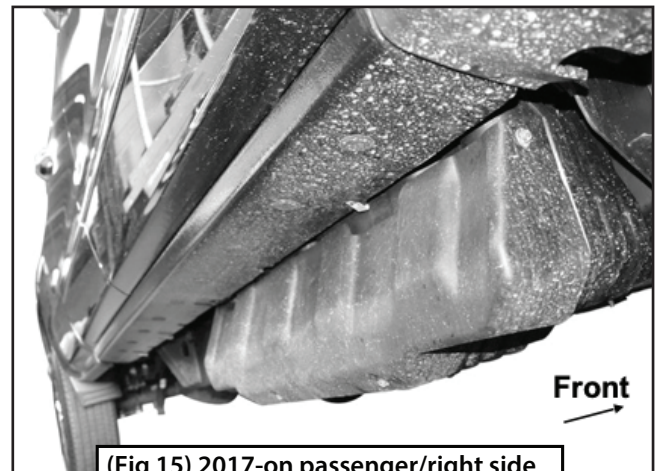

(Fig 15) 2017-on passenger/right side pictured with DEF plastic tank cover. Remove (4) hex bolts to remove plastic cover only. DO NOT remove tank



(Fig 16) 2017-on Passenger/Right side DEF cover removed

STEP 9

Locate the first tab on the edge of the pinch weld on the passenger side (Figs 2-4, 17). Select the Passenger/Right Front Upper Bracket (Fig 18). Repeat **STEPS 2 & 3** to attach the Upper Bracket Ⓧ to the side of the body panel. DO NOT tighten hardware at this time.

Passenger/Right Side Installation Pictured

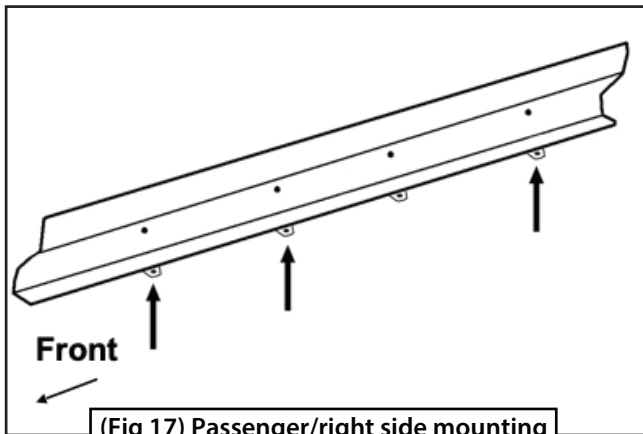

(Fig 17) Passenger/right side mounting locations from back of body panel

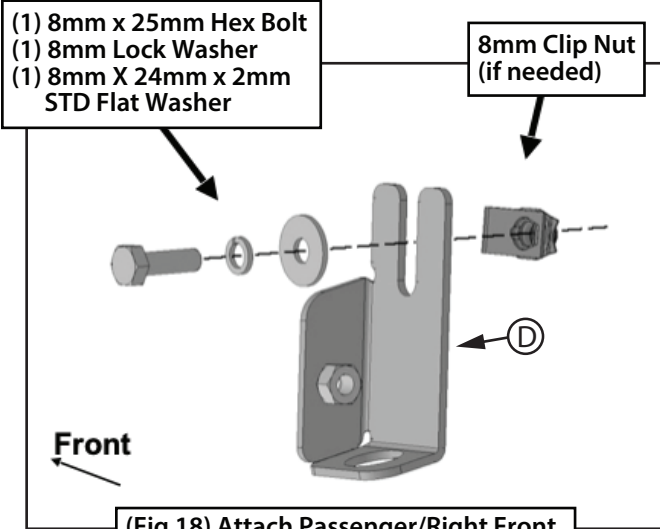

(Fig 18) Attach Passenger/Right Front Upper Bracket ① to side of body panel (all models)

STEP 10

Line up the hole in the bottom of the Upper Bracket ① with the hole in the tab on the pinch weld.

Models with a weld-nut:

- a. Slide the bottom of the Upper Bracket over the weld-nut (Fig 2)
- b. Select the Passenger/Right Front Lower Bracket ② . Attach the Lower Bracket to the bottom of the pinch weld with (1) 8mm x 40mm Hex Bolt, (1) 8mm Lock Washer and (1) 8mm x 28mm Large Flat Washer into the weld-nut and Upper Bracket that are above the pinch weld (Fig 19). Leave loose at this time.

Passenger/Right Side Installation Pictured

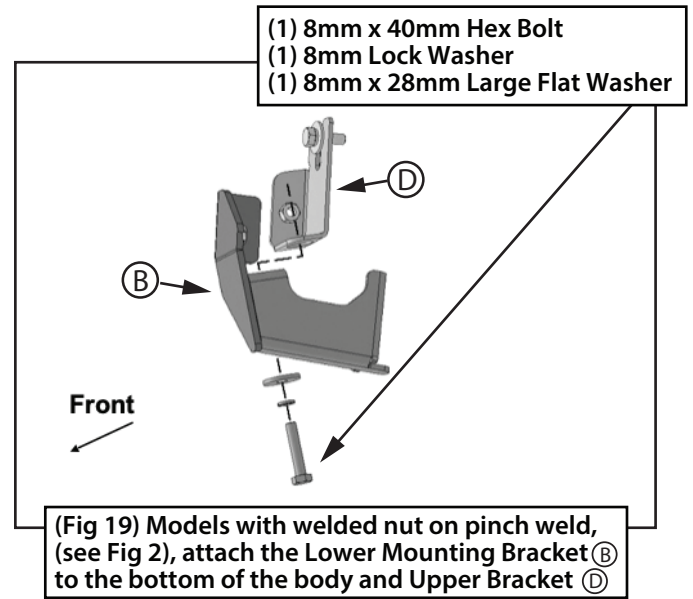

(Fig 19) Models with welded nut on pinch weld, (see Fig 2), attach the Lower Mounting Bracket ② to the bottom of the body and Upper Bracket ①

Models with flat tab and hole:

- a. Insert the 8mm Bolt Plate down through the hole in the Upper Bracket ① and mounting tab (Figs 4 & 20).



(Fig 20) 8mm Bolt Plate. Use on models with open hole, flat tab on pinch weld (see Fig 4)

- b. Attach the Lower Bracket ② to the bottom of the pinch weld and thread the Bolt Plate with (1) 8mm x 28mm Large Flat Washer and (1) 8mm Nylon Lock Nut (Fig 21). DO NOT tighten hardware.

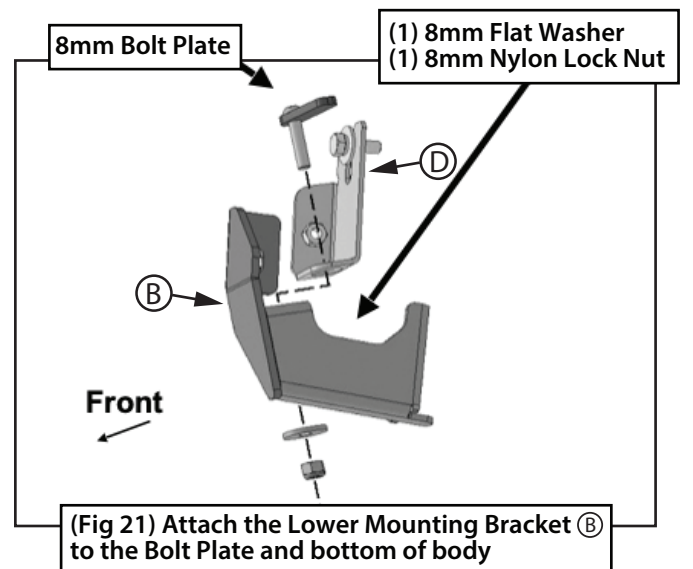

(Fig 21) Attach the Lower Mounting Bracket ② to the Bolt Plate and bottom of body

STEP 11

Attach the top tab of Lower Bracket ② to the side of the Upper Bracket ① with (1) 8mm x 25mm Hex Bolt, (1) 8mm Lock Washer and (1) 8mm x 24mm STD Flat Washer (Fig 22). DO NOT tighten hardware.

Passenger/Right Side Installation Pictured

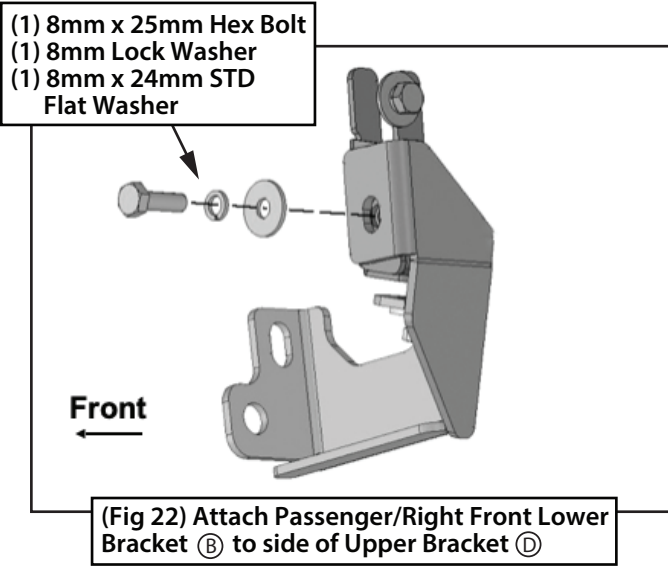

STEP 13

Continue to the rear mounting location. Repeat **STEP 12** to attach the remaining Passenger/Right Center/Rear Bracket ③ to the rear mounting location (Fig 23).

STEP 14

Repeat **STEPS 6 & 7** to attach the Passenger/Right TYGER LanderX (Figs 24-28).

Passenger/Right Side Installation Pictured

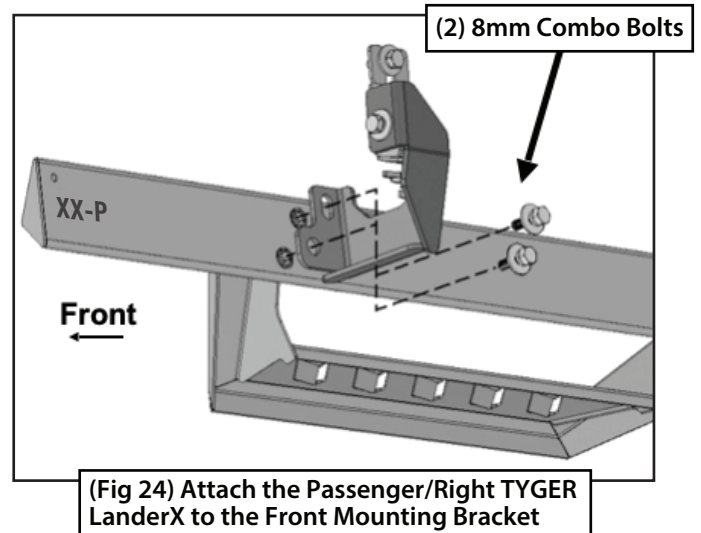

STEP 12

Move to the center mounting location. Select (1) Passenger/Right Center/Rear Bracket ③ (Fig 23). Repeat **STEPS 1-3** to attach the Bracket to the mounting location.

Passenger/Right Side Installation Pictured

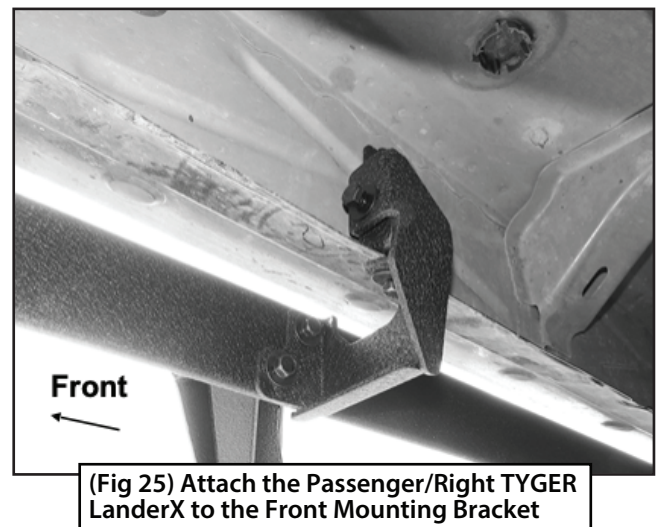
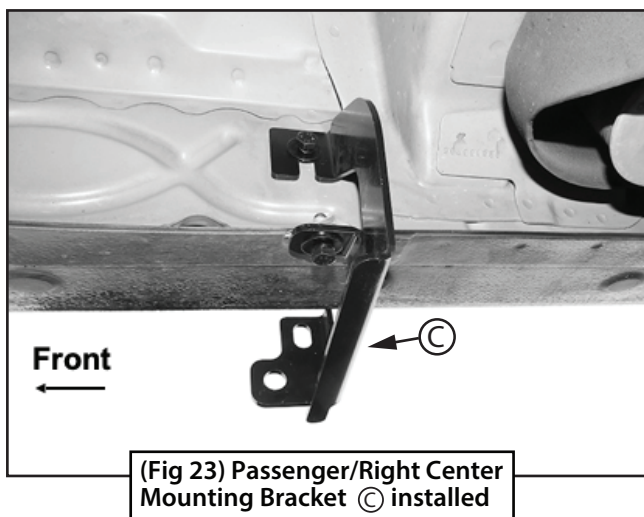

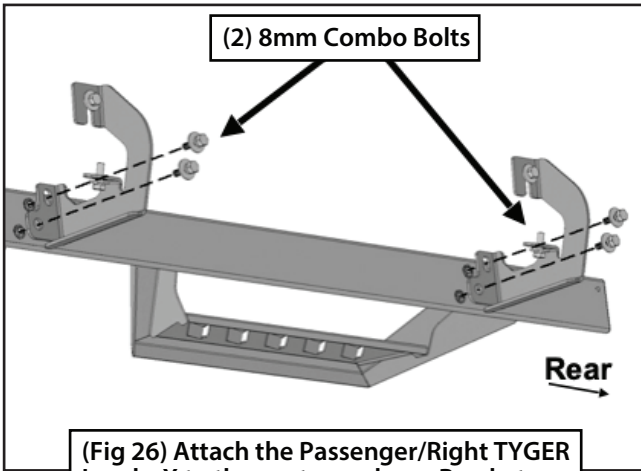

(Fig 26) Attach the Passenger/Right TYGER LanderX to the center and rear Brackets

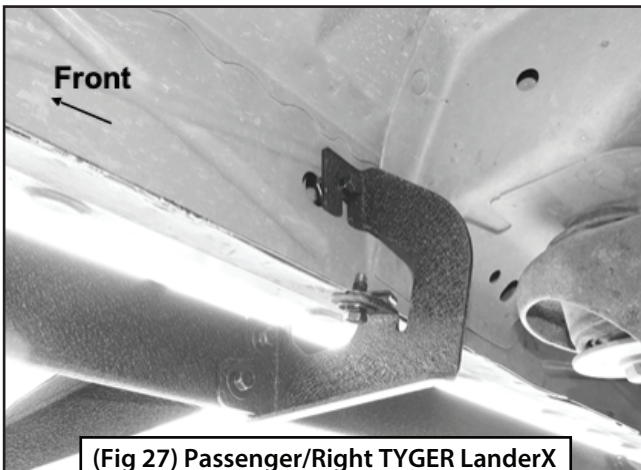

(Fig 27) Passenger/Right TYGER LanderX attached to the Center Bracket ©

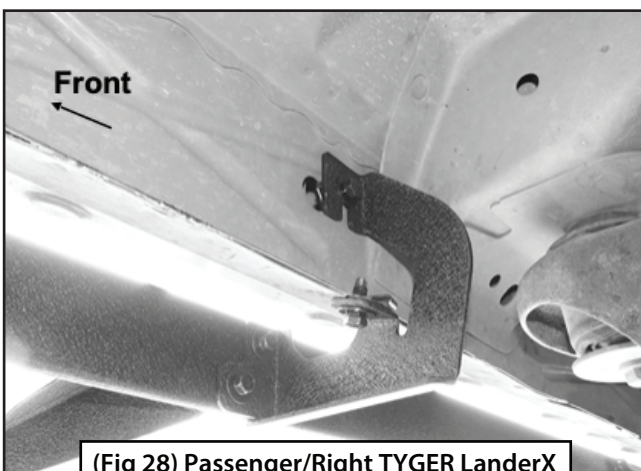

(Fig 28) Passenger/Right TYGER LanderX attached to the Rear Bracket ©

STEP 15

Once the Side Steps are installed, lined up to side of vehicle and all hardware fully tightened — if reequipped, reinstall the DEF tank and cover as described in **STEP 8**.

- a. **2017-on 2500-3500 DEF tank models only:** Hold the DEF cover up in place and mark the Center Bracket location onto the cover (Fig 29). Use a sharp knife or hacksaw blade to carefully cut a slot in the plastic cover to clear the **2nd** Bracket (Fig 30).

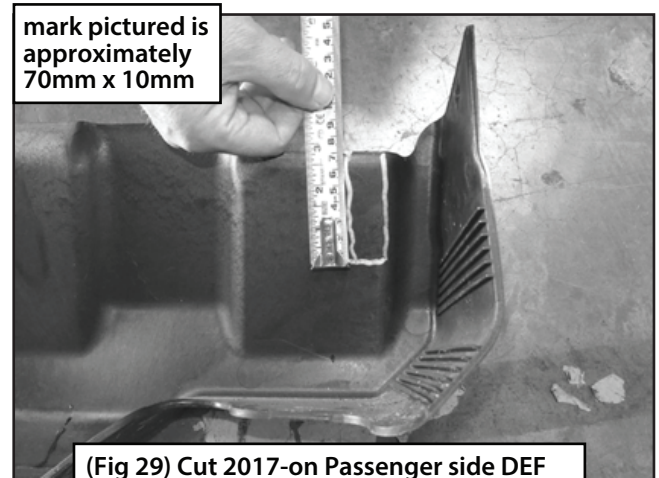

(Fig 29) Cut 2017-on Passenger side DEF cover to clear 2nd Bracket only (see Fig 25)

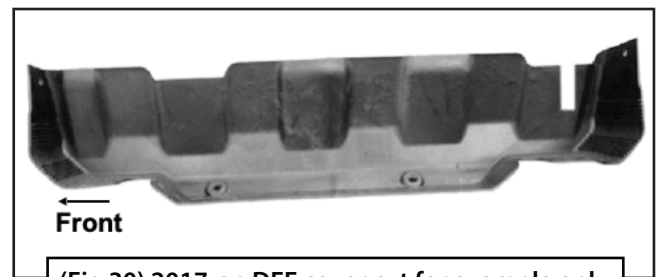

(Fig 30) 2017-on DEF cover cut for example only

STEP 16

Do periodic inspections to the installation to make sure that all hardware is secure and tight.