



TYGER LanderX

TG-LX3D82348

Scan to Download the Latest Digital Version



BEFORE INSTALLATION

READ INSTRUCTIONS CAREFULLY BEFORE STARTING INSTALLATION. REMOVE CONTENTS FROM BOX AND VERIFY ALL PARTS ARE PRESENT. FAILURE TO IDENTIFY DAMAGE BEFORE INSTALLATION COULD LEAD TO A REJECTION OF ANY CLAIM. IF MISSING PARTS OR ANY DAMAGE FOUND, PLEASE TAKE A PICTURE FOR THE CLAIM PURPOSE. TO FILE YOUR CLAIM, PLEASE VISIT: WWW.TYGERAUTO.COM/CONTACT

TORQUE VALUES

Fastener Size	Class 8.8 Torque (ft-lbs)	Class 10.9 Torque (ft-lbs)
6mm	6-7	6-7
8mm	15-16	22-23
10mm	31-32	44-45
12mm	54-55	78-79
14mm	87-88	125-126

- x1 Driver/Left TYGER LanderX **D**
- x1 Passenger/Right TYGER LanderX **P**
- x2 Driver Front and Passenger Rear Mounting Brackets **(A)**
- x2 Driver Rear and Passenger Front Mounting Brackets **(C)**
- x1 Driver/Left Center Mounting Bracket **(B)**
- x1 Passenger/Right Center Mounting Bracket **(D)**
- x6 8mm Bolt/Nut Plates
- x12 8mm x 30mm Hex Bolts
- x12 8mm x 25mm Combo Bolts
- x12 8mm x 24mm OD x 2mm Flat Washers
- x12 8mm Lock Washers
- x6 8mm Hex Nuts
- x6 8mm Plastic Retainers
- x10 6mm x 25mm Button Head Bolts
- x20 6mm x 18mm OD x 1.6mm Flat Washers
- x10 6mm Serrated Flange Nuts
- x4 16mm x 60mm Large Spacers
- x2 16mm x 34mm Small Spacers
- x1 4mm Hex Wrench

Parts List

Reference the letters printed on the bottom of brackets to determine mounting locations

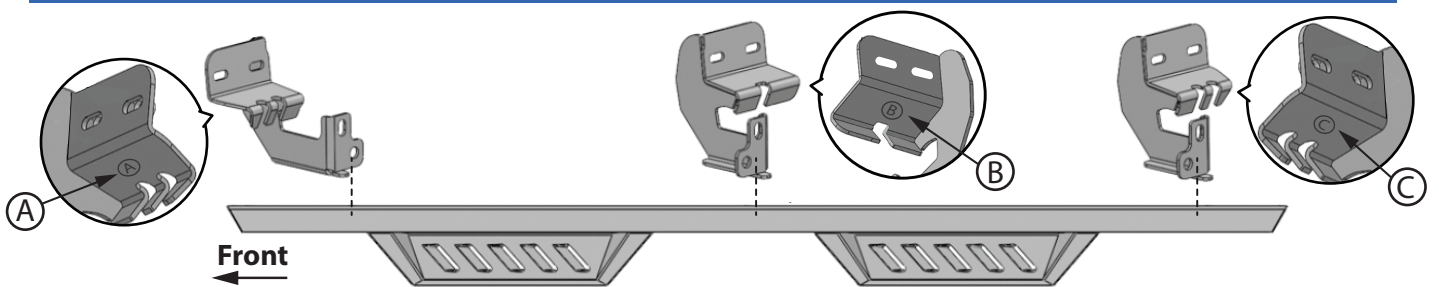

Driver/Left TYGER LanderX

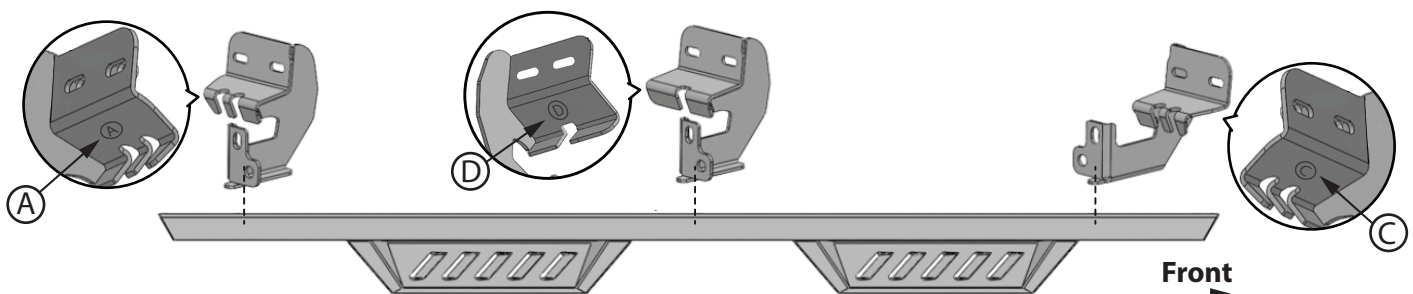

Passenger/Right TYGER LanderX

Bottom View

ATTENTION: Refer to the **D** or **P** labelling on the tubes to determine the Driver or Passenger side steps.

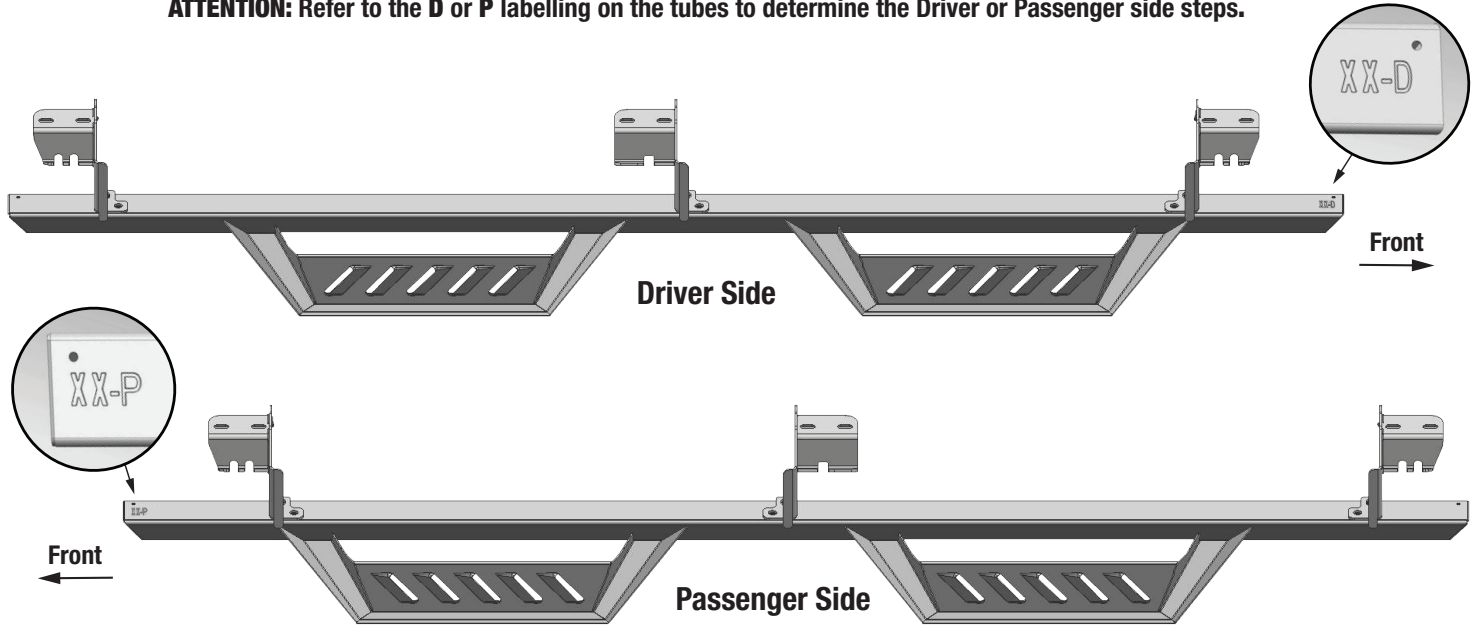

PROCEDURE:

REMOVE CONTENTS FROM BOX. VERIFY ALL PARTS ARE PRESENT. READ INSTRUCTIONS CAREFULLY BEFORE STARTING INSTALLATION. DRILLING MAY BE REQUIRED.

- a. Select (1) 8mm Bolt/nut Plate (Fig 2). Partially thread an 8mm Hex Bolt onto the threaded of the Nut Plate (Fig 3). Thread the Hex Bolt in until it is flush with the welded nut. Use the Hex Bolt as a handle and insert the Bolt and Nut Plate into the oval hole (Fig 4). Feed the threaded bolt on the Bolt Plate through one of the hex shaped factory holes.

STEP 1

Starting at the driver side-front of the vehicle, remove the sealing tape covering the factory holes in the side of the inner panel (Fig 1).

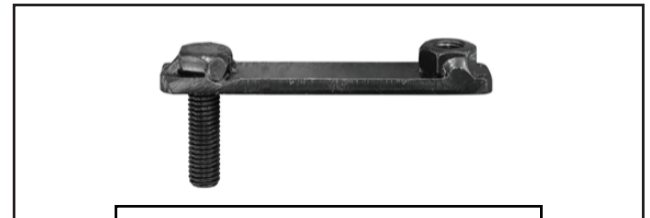
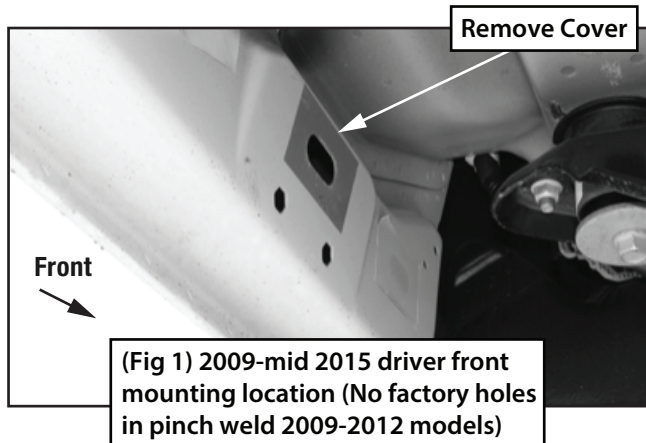

(Fig 2) 8mm Bolt-Nut Plate, NOTE: 8mm Bolt-Nut Plate is not required on models with threaded inserts

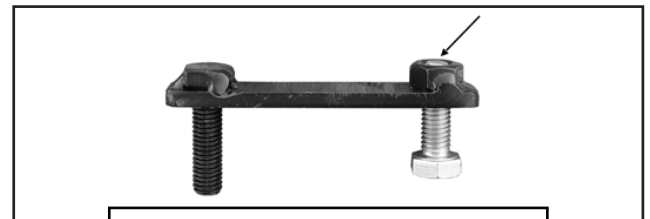

(Fig 3) Thread (1) 8mm Hex Bolt into the nut on the plate. Stop when bolt reaches end of nut as pictured

STEP 2

Determine the correct procedure to attach the driver side front Bracket for your model/year:

Models without factory threaded inserts in body panel:

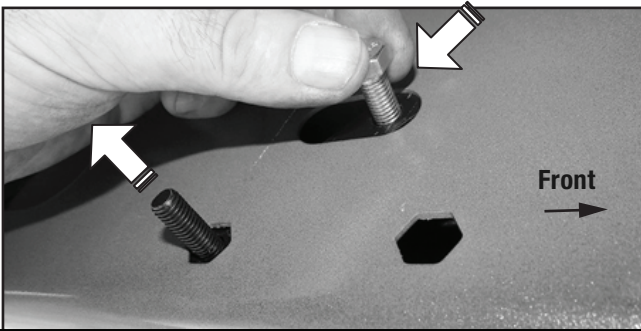

(Fig 4) Use the loose Hex Bolt as a handle. Insert the Bolt Plate into the oval hole and feed the threaded end out either factory hex shaped hole. **IMPORTANT:** DO NOT let go of the hex bolt until after Plastic Retainer has been threaded onto bolt (Fig 5)

- b. Thread (1) 8mm Plastic Retainer onto the threaded end and down tight against the body panel (Fig 5). **NOTE:** The Plastic Retainer is designed to keep the Bolt/Nut Plate from falling into the body panel and to aid in Bracket installation.

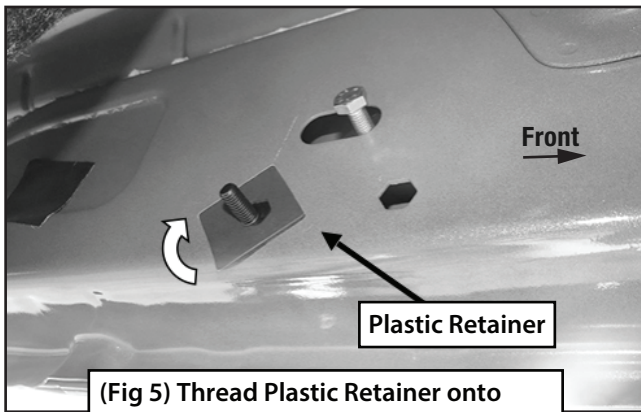

(Fig 5) Thread Plastic Retainer onto Bolt Plate to hold Bolt Plate in position.

- c. Select (1) Driver/Left Front Bracket (A) (Fig 6). Attach the Bracket to the threaded end of the Bolt Plate with (1) 8mm Flat Washer, (1) 8mm Lock washer and (1) 8mm Hex Nut (Fig 6).

IMPORTANT: Driver/Left Front Bracket (A) is the same as the Passenger/Right Rear Brackets (A). DO NOT tighten hardware at this time.

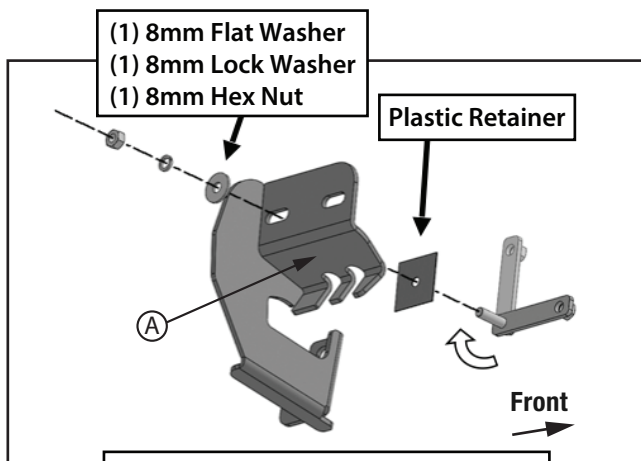

(Fig 6) Remove 8mm Hex Bolt. Rotate Bolt Plate to line up with remaining factory hex shaped hole

- d. Remove the 8mm Hex Bolt from the nut on the Bolt Plate from **STEP 2a**. Rotate the Bolt on the Bolt Plate until the threaded nut lines up with the remaining hole in the Mounting Bracket and body panel (Fig 7). Attach the Bracket to the threaded Nut Plate with (1) 8mm x 30mm Hex Bolt, (1) 8mm Lock Washer and (1) 8mm Flat Washer (Fig 7). DO NOT tighten hardware.

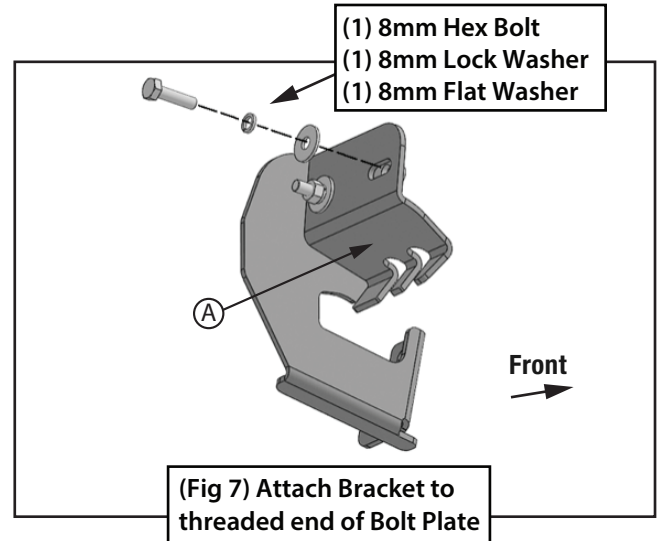

(Fig 7) Attach Bracket to threaded end of Bolt Plate

Models with factory threaded inserts:

- a. Attach (1) Driver/Left Front Mounting Bracket (A) to the threaded inserts with (2) 8mm x 30mm Hex Bolts, (2) 8mm Lock Washers and (2) 8mm Flat Washer (Figs 8 & 9). DO NOT tighten hardware.

IMPORTANT: Rust or dirt may build up overtime and clog up the holes preventing the bolts to be installed. In this case, use a 8-1.25mm Tap (not included) to clear and cut new threads to allow the bolts to be mounted.

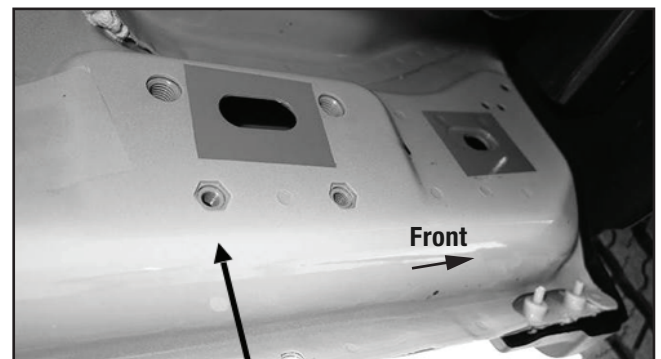

(Fig 8) Driver/left side front mid 2015-on (example of models with factory installed threaded inserts)

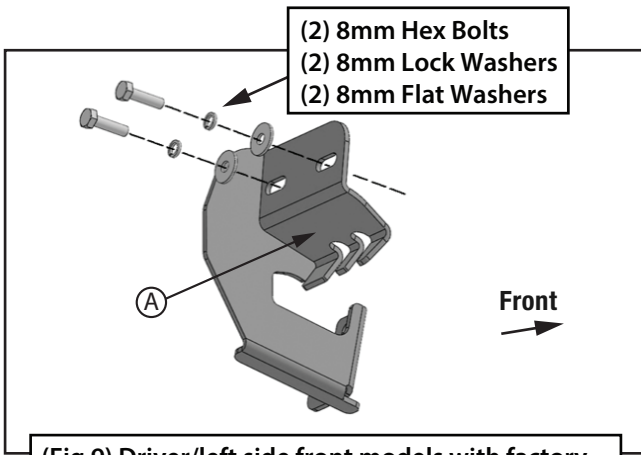

(Fig 9) Driver/left side front models with factory installed threaded inserts. Bolt Plate not required

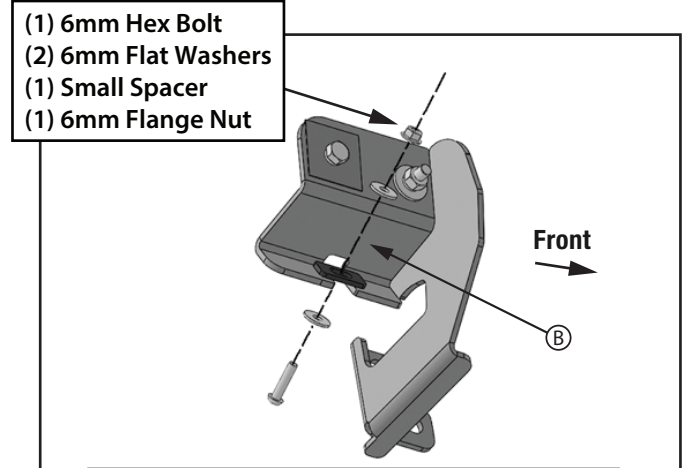

(Fig 10B) Attach (1) Center Mounting Bracket to back of pinch weld (models with factory holes in pinch weld only)

STEP 3

Next, attach the Bracket to the back of the pinch weld with (2) 6mm Button Head Bolts, (4) 6mm Flat Washers, (1) 16mm x 60mm Spacer Plate and (2) 6mm Flange Nuts (Fig 10A). **DO NOT** fully tighten hardware at this time. **DO NOT** fully tighten hardware. **IMPORTANT: 2009-12 models** not equipped with factory holes will require drilling through the pinch weld to fully attach Bracket. **DO NOT** drill through pinch weld at this time, (see **STEP 7**).

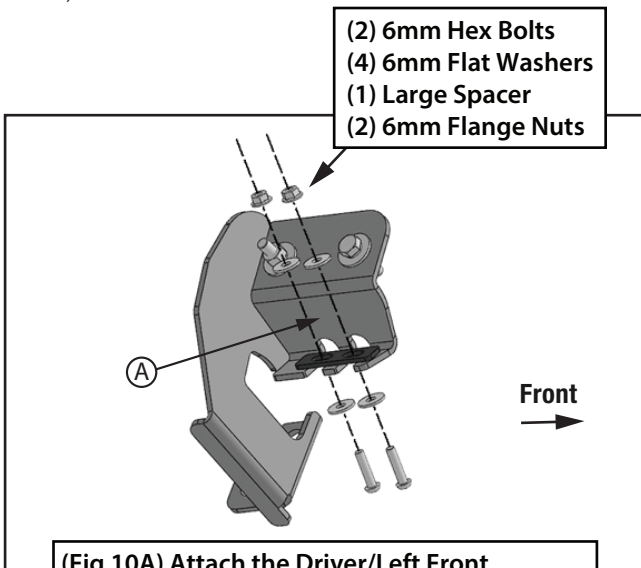

(Fig 10A) Attach the Driver/Left Front Mounting Bracket to back of pinch weld (models with factory holes in pinch weld only)

STEP 4

Move along the side of the body panel to the center mounting location (Fig 11). Repeat the appropriate **STEPS 2-4** to install the Driver/Left Center Bracket **B**. **IMPORTANT:** The Center Mounting Bracket **B** will use the 16mm x 34mm Spacer Plate (Fig 10B).

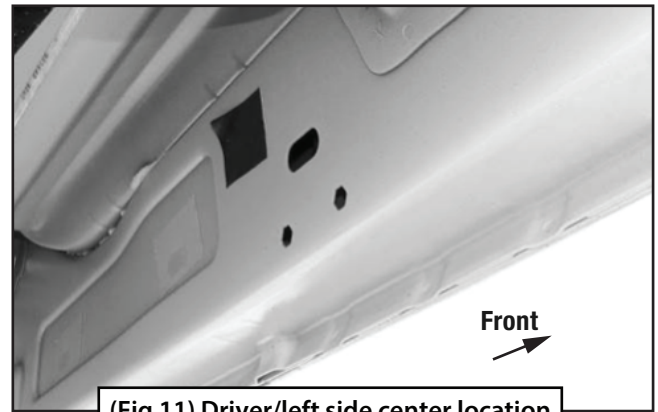

(Fig 11) Driver/left side center location

STEP 5

Move to the rear location (Fig 12). Repeat **STEPS 1-3** to attach (1) Driver/Left Rear Mounting Bracket **C** to the driver/left rear mounting location.



(Fig 12) Driver/left rear mounting location

STEP 6

Select the Driver/Left TYGER LanderX. Place the TYGER LanderX onto the Mounting Brackets and attach with (6) 8mm Combo Bolts (Fig 13). DO NOT tighten hardware.

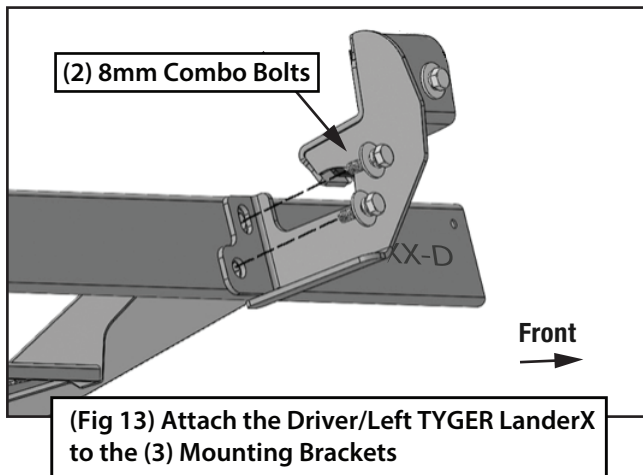

STEP 7

Properly level and adjust the TYGER LanderX and fully tighten all hardware.

2009-12 models requiring drilling through pinch trim:

- a. Level the TYGER LanderX to the vehicle. Make sure all (3) Brackets are tight against the bottom of the body panel and tighten all mounting hardware.
- b. Mark the location of the slots onto the pinch weld.
- c. Drill (2) 1/4" holes through the pinch weld for each Bracket. **IMPORTANT:** DO NOT drill too close to the bottom edge of the pinch weld. Drill the holes in the center of the marked slots.
- d. Repeat **STEP 3** to attach the Brackets to the drilled holes in the pinch weld. Check for level then fully tighten all hardware.

STEP 8

Repeat **STEPS 1-7** to attach the Passenger/Right TYGER LanderX.

STEP 9

Do periodic inspections to the installation to make sure that all hardware is secure and tight.