



TYGER LanderX

TG-LX3D82468

BEFORE INSTALLATION

READ INSTRUCTIONS CAREFULLY BEFORE STARTING INSTALLATION. REMOVE CONTENTS FROM BOX AND VERIFY ALL PARTS ARE PRESENT. FAILURE TO IDENTIFY DAMAGE BEFORE INSTALLATION COULD LEAD TO A REJECTION OF ANY CLAIM. IF MISSING PARTS OR ANY DAMAGE FOUND, PLEASE TAKE A PICTURE FOR THE CLAIM PURPOSE. TO FILE YOUR CLAIM, PLEASE VISIT: WWW.TYGERAUTO.COM/CONTACT

TORQUE VALUES

Fastener Size	Class 8.8 Torque (ft-lbs)	Class 10.9 Torque (ft-lbs)
6mm	6-7	6-7
8mm	15-16	22-23
10mm	31-32	44-45
12mm	54-55	78-79
14mm	87-88	125-126

- x1** Driver/Left TYGER LanderX
- x1** Passenger/Right TYGER LanderX
- x4** Front/Rear Base Brackets (C)
- x4** Front/Rear Mounting Brackets (A)
- x2** Center Base Bracket (D)
- x2** Center Mounting Brackets (B)
- x12** 8-1.25mm x 25mm Combo Bolts
- x8** 8-1.25mm x 25mm Hex Bolts
- x20** 8mm x 24mm x 2mm STD Flat Washers
- x16** 8mm x 16mm x 1.6mm Small Flat Washers
- x28** 8mm Nylon Lock Nuts

Parts List

Reference the letters printed on the brackets to determine mounting locations

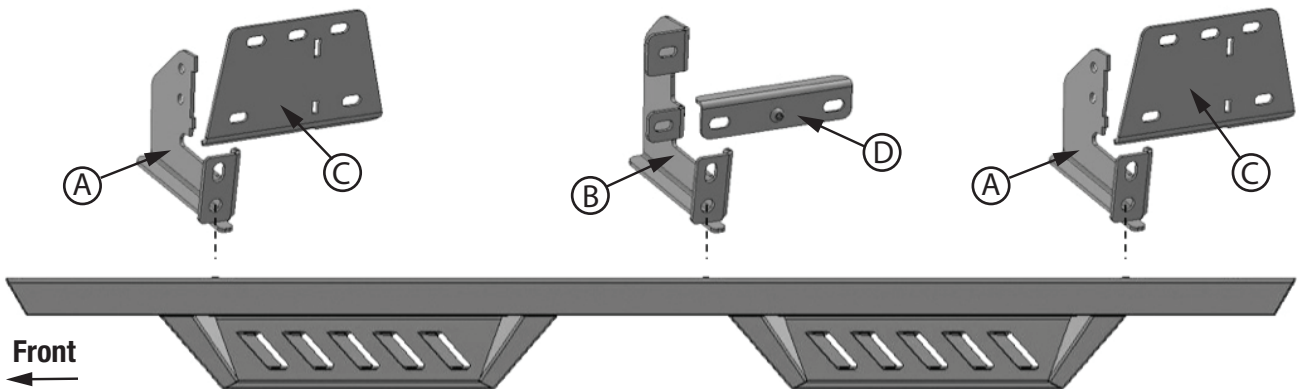

Driver/Left TYGER LanderX

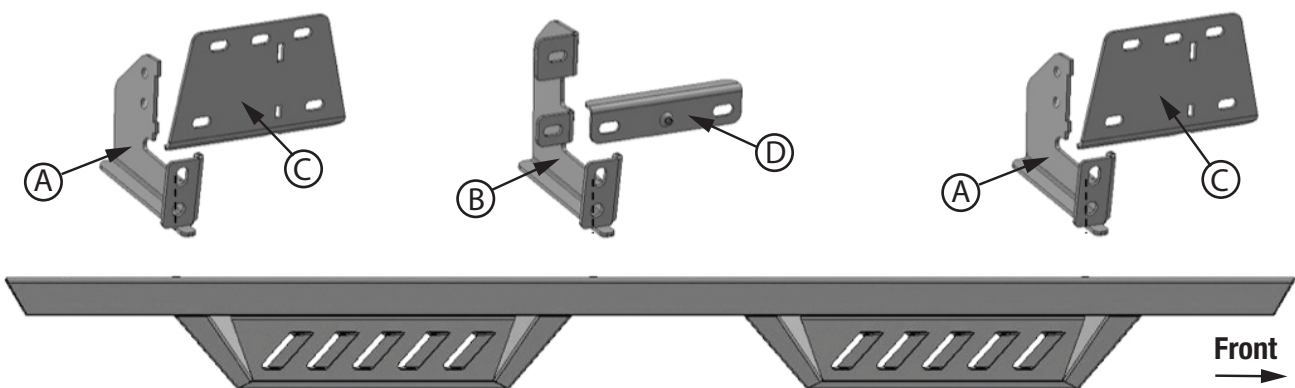

Passenger/Right TYGER LanderX

Bottom View

ATTENTION: Refer to the **D** or **P** labelling on the tubes to determine the Driver or Passenger side steps.

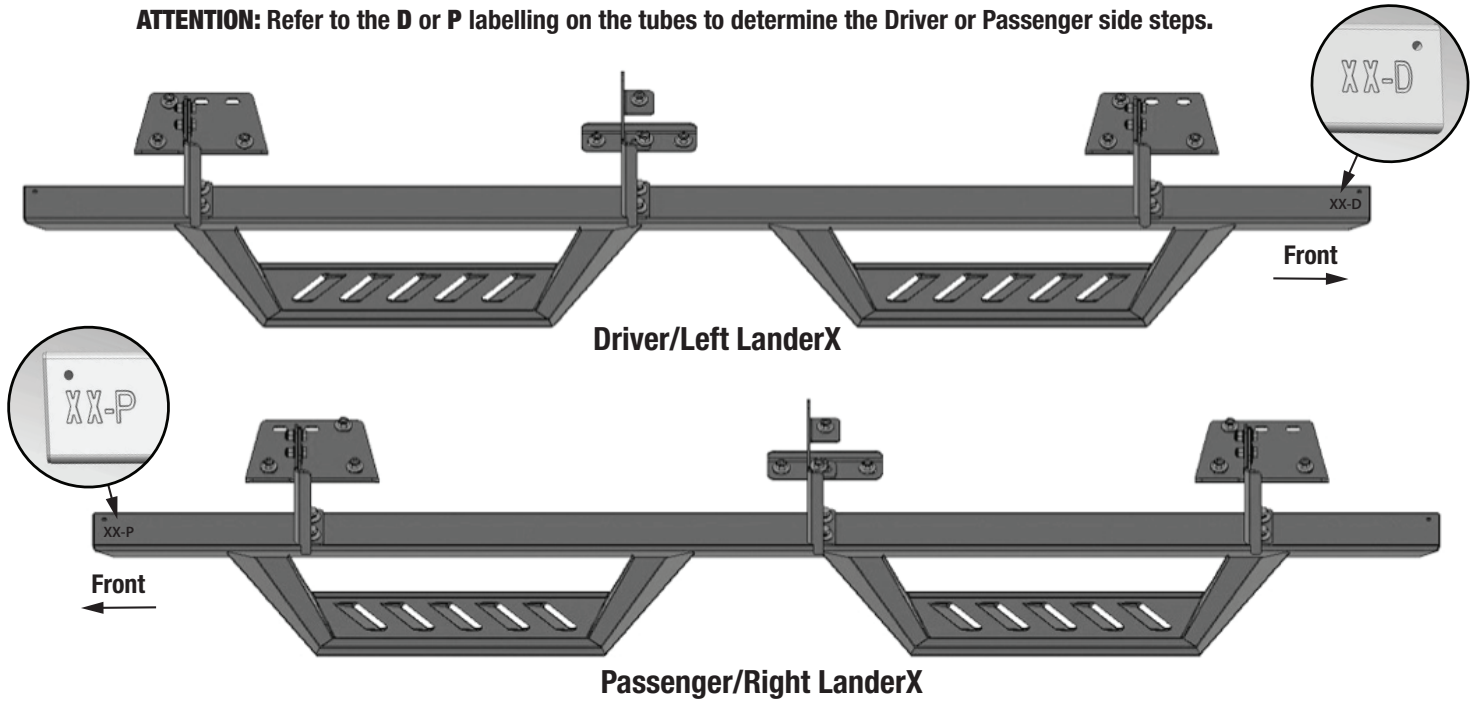

PROCEDURE:

REMOVE CONTENTS FROM BOX. VERIFY ALL PARTS ARE PRESENT. READ INSTRUCTIONS CAREFULLY BEFORE STARTING INSTALLATION. ASSISTANCE IS RECOMMENDED.

STEP 2

Select (1) Front/Rear Base Bracket © (Fig 2). **NOTE:** The Front/Rear Base © and Mounting Brackets ① are the same and fit both driver or passenger sides. Attach Base Bracket © to the 3 factory studs with (3) 8mm x 24mm STD Flat Washers and (3) 8mm Nylon Lock Nuts (Figs 2 & 3). Leave bracket loose at this time.

Passenger/right side Installation Pictured

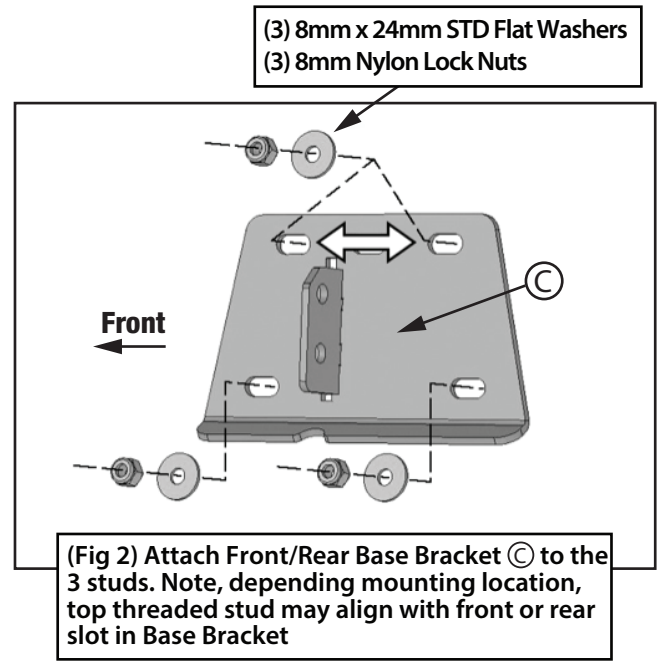

STEP 1

Start the installation under the passenger/right side of the vehicle. Locate the front 3 factory studs along the inner sidewall of the body panel (Fig 1). **NOTE:** Use a wire brush or thread die to remove paint buildup on the threaded studs.

Passenger/right side Installation Pictured

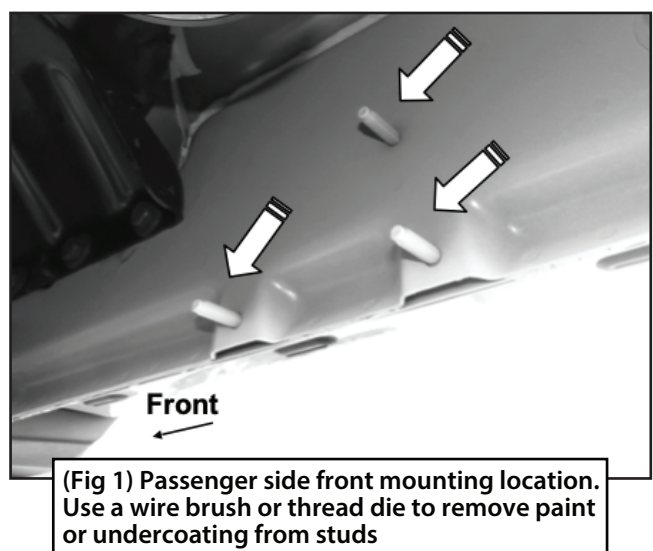

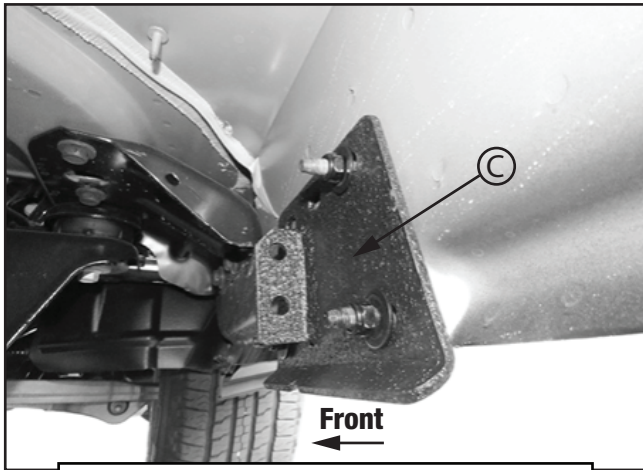

(Fig 3) Passenger/Right Front Left/Right Base Bracket © attached to passenger/right front mounting location

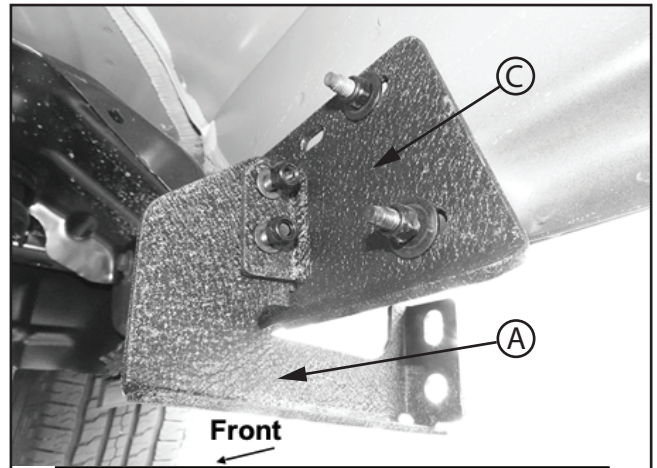

(Fig 5) Passenger/right front Brackets installed

STEP 3

Next, select (1) Front/Rear Mounting Bracket (A) (Fig 4). **NOTE:** The Front/Rear Base © and Mounting Brackets (A) are the same and fit both driver or passenger sides. Slide the tabs on the Mounting Bracket (A) into the slots in the Base Bracket ©. Attach the Mounting Bracket (A) to the tab on the back of the Base Bracket © with the included (2) 8mm x 25mm Hex Bolts, (4) 8mm x 16mm Small Flat Washers and (2) 8mm Nylon Lock Nuts (Figs 4 & 5). Leave bracket loose at this time.

Passenger/right side Installation Pictured

- (2) 8mm x 25mm Hex Bolts
- (4) 8mm x 16mm Small Flat Washers
- (2) 8mm Nylon Lock Nuts

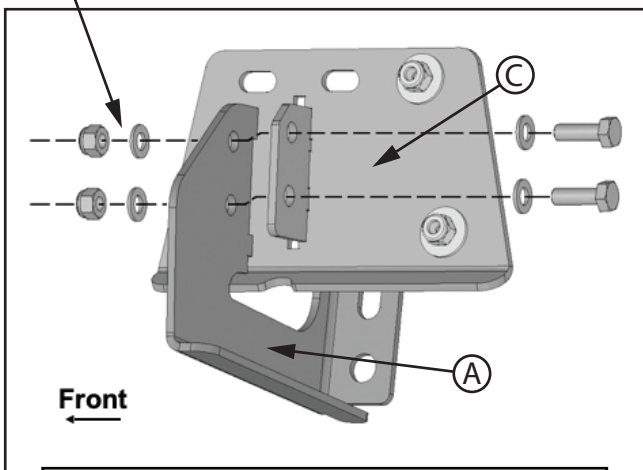

(Fig 4) Attach Front/Rear Mounting Bracket (A) to the tab on the back of the Front/Rear Base ©

STEP 4

Move to the center mounting location and locate the 3 mounting studs (Fig 6). Repeat **STEP 1** to clear paint or undercoating from the studs.

Passenger/right side Installation Pictured



(Fig 6) Passenger/right center mounting location

STEP 5

Select (1) Center Base Bracket (D) (Fig 7). **NOTE:** Center Base © and Center Mounting Bracket (B) are the same and fit both driver or passenger sides. Attach the Base Bracket © to the 2 bottom factory studs with (2) 8mm x 24mm STD Flat Washers and (2) 8mm Nylon Lock Nuts (Figs 7 & 8). Leave hardware loose at this time.

Passenger/right side Installation Pictured

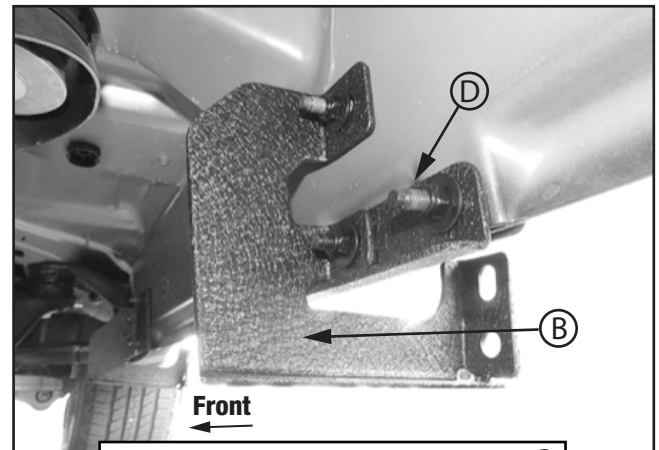
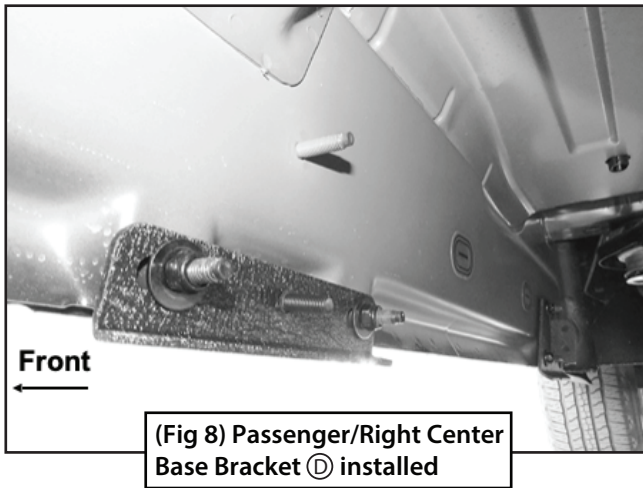
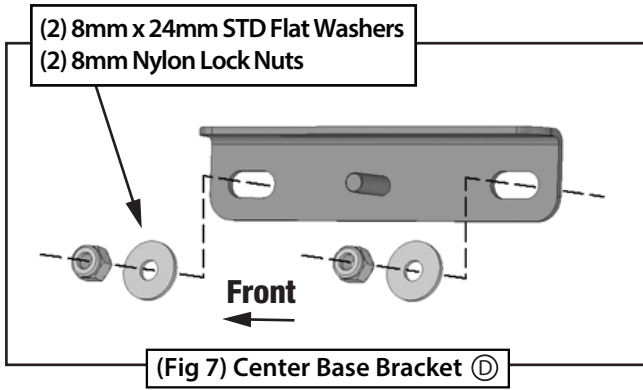

(Fig 10) Passenger/Right Center Base (D) and Mounting Bracket (B) installed

STEP 7

Move to the passenger/right rear mounting location (Fig 11). Repeat **STEPS 1-3** to clean the studs and attach (1) Front/Rear Mounting Base (C) and (1) Front/Rear Mounting Bracket (A) to the rear mounting location along the body panel (Figs 2, 4 & 12).

Passenger/right side Installation Pictured

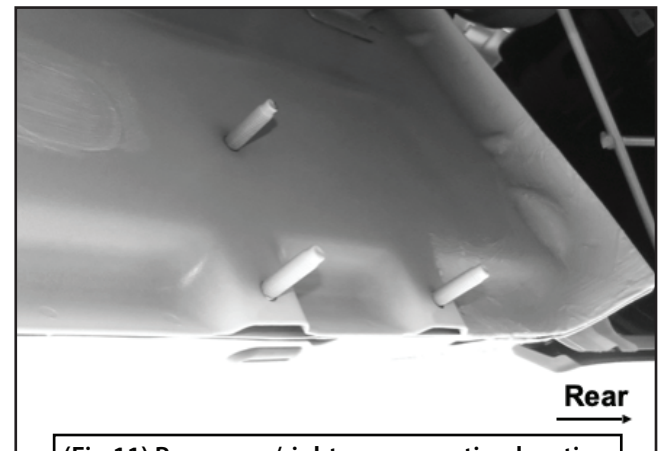

(Fig 11) Passenger/right rear mounting location

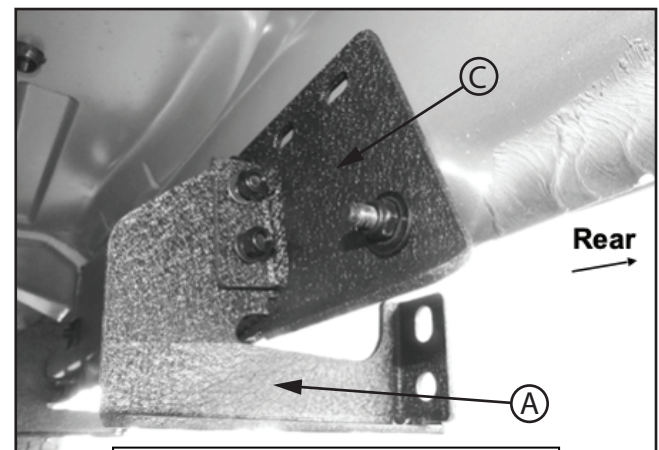

(Fig 12) Passenger/Right Rear Base (C) and Mounting Bracket (A) installed

STEP 6

Next, select (1) Center Mounting Bracket (B) (Fig 2). **NOTE:** The two Center Mounting Brackets (B) are the same and fit both driver or passenger sides. Attach the Mounting Bracket (B) to the top factory stud and stud on Center Base Bracket (D) with (2) 8mm x 24mm STD Flat Washers and (2) 8mm Nylon Lock Nuts (Figs 9 & 10). Leave bracket loose at this time.

Passenger/right side Installation Pictured

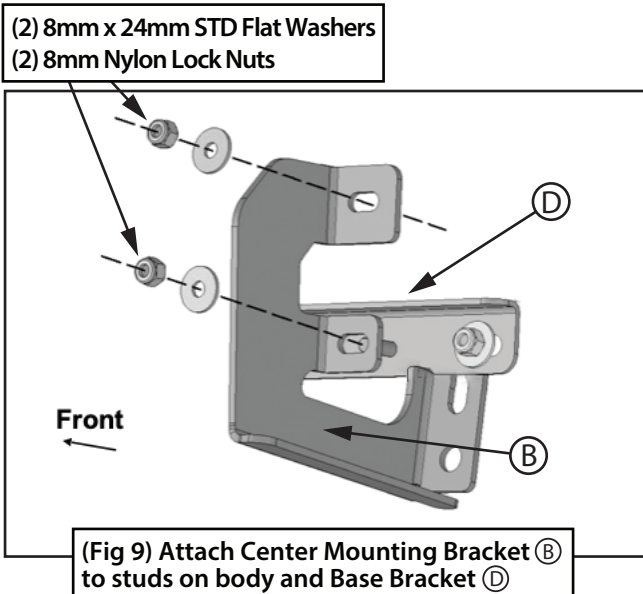

STEP 8

Select the Passenger/Right TYGER LanderX. Carefully position the TYGER LanderX up to the (3) Mounting Brackets. **IMPORTANT:** DO NOT slide, (front to back or rotate), the TYGER LanderX on the Brackets or damage to the finish may result. Attach the TYGER LanderX to the (3) Brackets with (6) 8mm Combination Hex Bolts (Figs 13-17). DO NOT fully tighten at this time.

Passenger/right side Installation Pictured

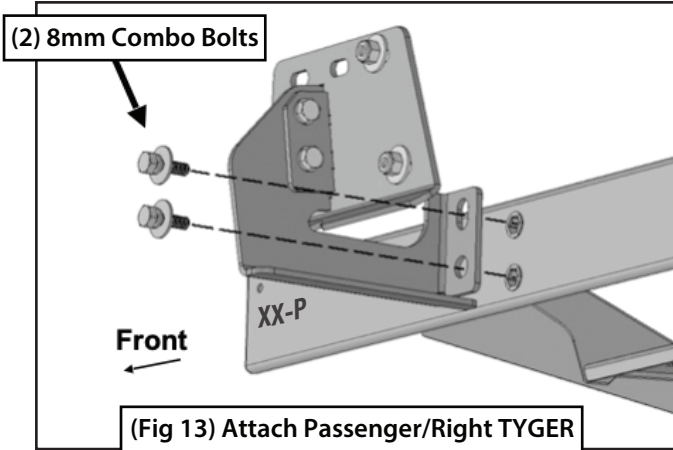

(Fig 13) Attach Passenger/Right TYGER LanderX to Front Mounting Bracket

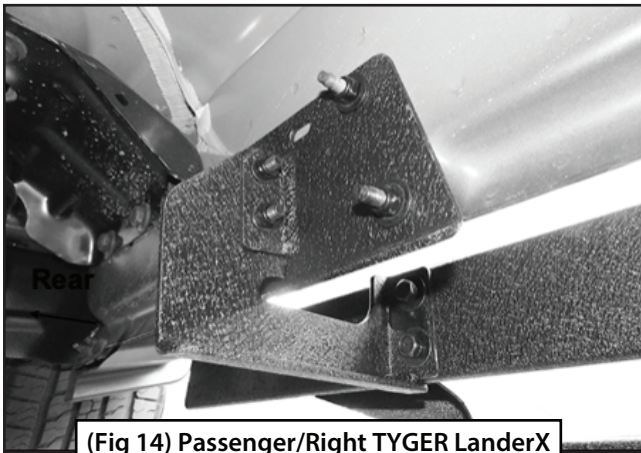

(Fig 14) Passenger/Right TYGER LanderX attached to Front Mounting Bracket

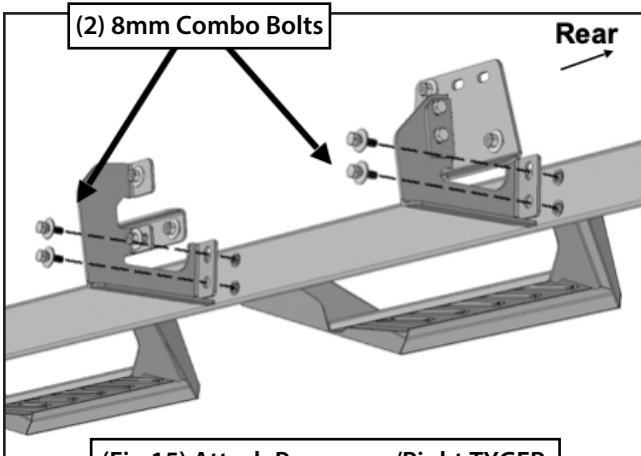

(Fig 15) Attach Passenger/Right TYGER LanderX to Center and Rear Brackets

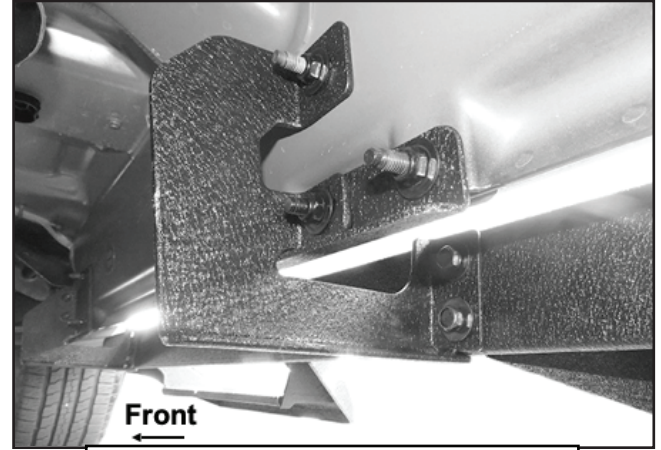

(Fig 16) Passenger/Right Center Brackets and TYGER LanderX installed

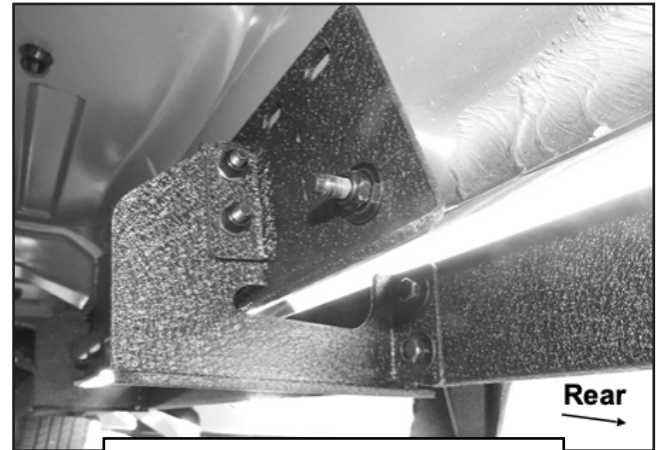

(Fig 17) Passenger/Right Rear Brackets and TYGER LanderX installed

STEP 9

Properly level and adjust the TYGER LanderX and fully tighten all hardware.



Complete Installation

STEP 10

Move to the driver/left side of the vehicle. Repeat **STEPS 1-9** for Driver/Left TYGER LanderX installation.

STEP 11

Do periodic inspections to the installation to make sure that all hardware is secure and tight.