



TYGER LanderX

TG-LX3F82368

BEFORE INSTALLATION

READ INSTRUCTIONS CAREFULLY BEFORE STARTING INSTALLATION. REMOVE CONTENTS FROM BOX AND VERIFY ALL PARTS ARE PRESENT. FAILURE TO IDENTIFY DAMAGE BEFORE INSTALLATION COULD LEAD TO A REJECTION OF ANY CLAIM. IF MISSING PARTS OR ANY DAMAGE FOUND, PLEASE TAKE A PICTURE FOR THE CLAIM PURPOSE. TO FILE YOUR CLAIM, PLEASE VISIT: WWW.TYGERAUTO.COM/CONTACT

TORQUE VALUES

Fastener Size	Class 8.8 Torque (ft-lbs)	Class 10.9 Torque (ft-lbs)
6mm	6-7	6-7
8mm	15-16	22-23
10mm	31-32	44-45
12mm	54-55	78-79
14mm	87-88	125-126

- x1** Driver/Left TYGER LanderX
- x1** Passenger/Right TYGER LanderX
- x2** Front Mounting Brackets
- x4** Center/Rear Mounting Brackets
- x6** Support Brackets
- x24** 8mm x 24mm OD x 2mm Flat Washers
- x24** 8mm Lock Nuts
- x18** 8mm Plastic Retainers
- x12** 8mm x 1.25mm x 25mm Combo Hex Bolts

Parts List

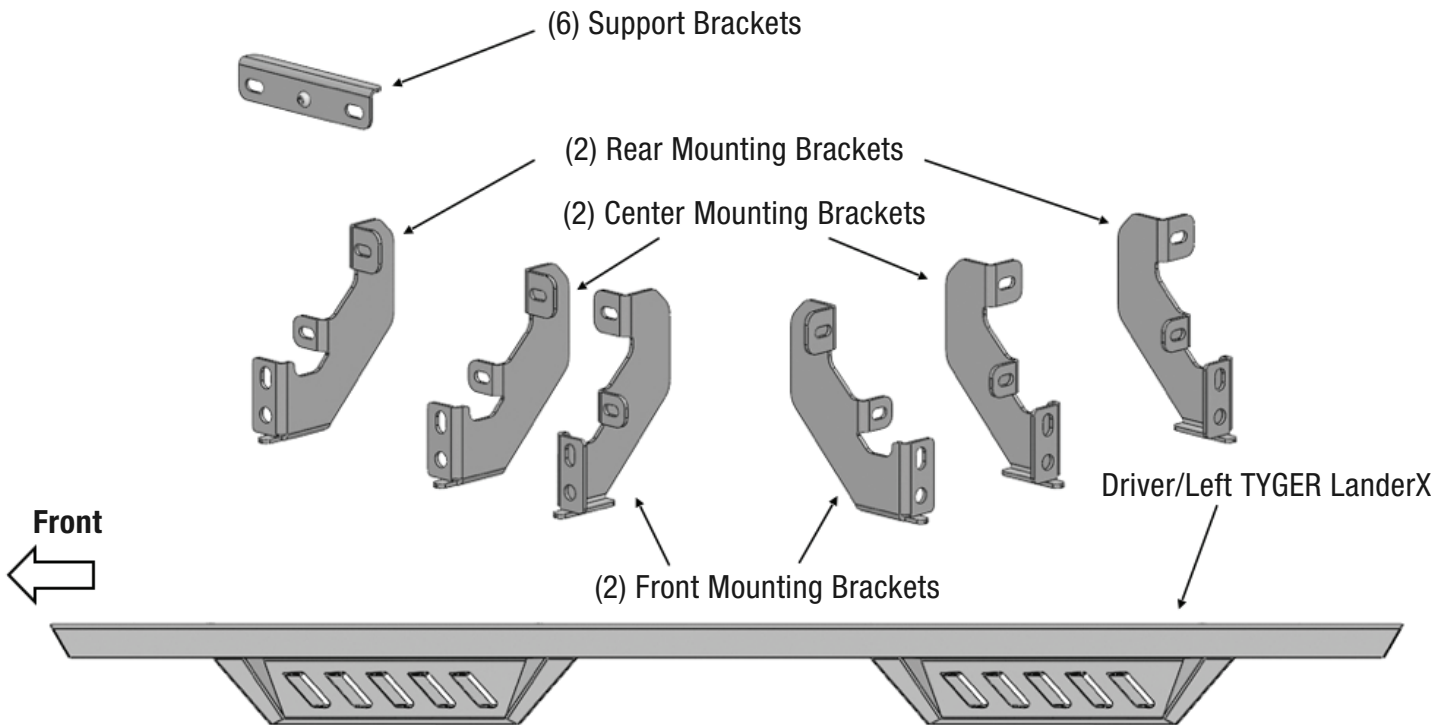

PROCEDURE:

REMOVE CONTENTS FROM BOX. VERIFY ALL PARTS ARE PRESENT. READ INSTRUCTIONS CAREFULLY. ASSISTANCE IS RECOMMENDED.

STEP 1

Start the installation under the driver/left side of the vehicle. Locate the front factory mounting location along the inner side of the body (Fig 1). Use a wire brush or thread chaser die to remove excess paint and/or undercoating from all studs.

Driver/Left Side Installation Pictured

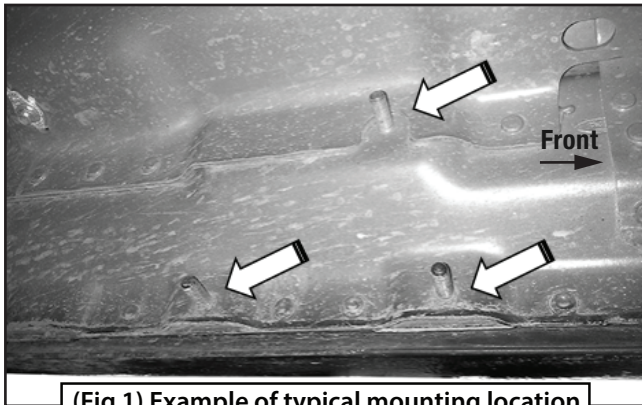

(Fig 1) Example of typical mounting location

STEP 2

Slide (1) Plastic Washer over each of the (3) factory mounting studs in the body panel (Figs 2-3). **IMPORTANT:** The Plastic Washers are designed to prevent corrosion between the aluminum body panel and the steel mounting brackets. **DO NOT install the Brackets without the Plastic Washers.**

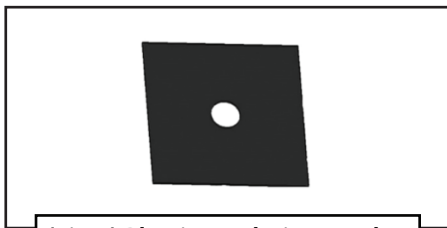

(Fig 2) Plastic Insulation Washer

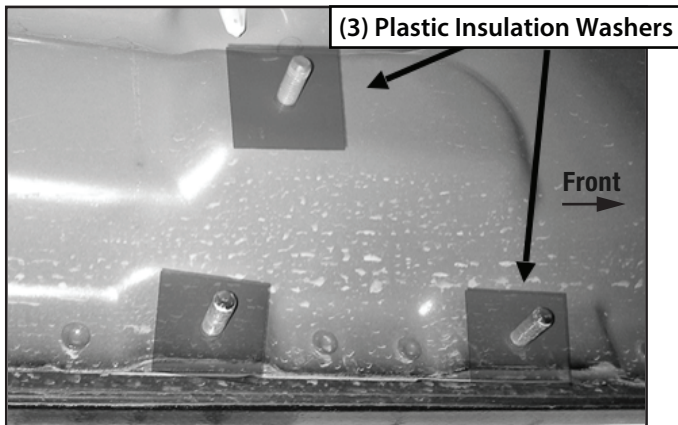

(Fig 3) Thread Plastic Washers onto all mounting studs

STEP 3

Select (1) Support Bracket (Fig 4). Attach the Bracket to the (2) studs on the pinch trim with (2) 8mm Flat Washers and (2) 8mm Nylon Lock Nuts (Figs 4 & 5). **DO NOT** tighten hardware.

Driver/Left Side Installation Pictured

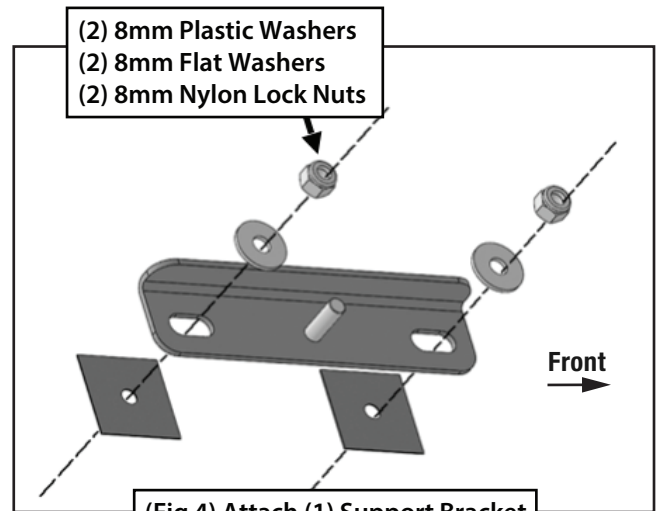

(Fig 4) Attach (1) Support Bracket to the mounting location

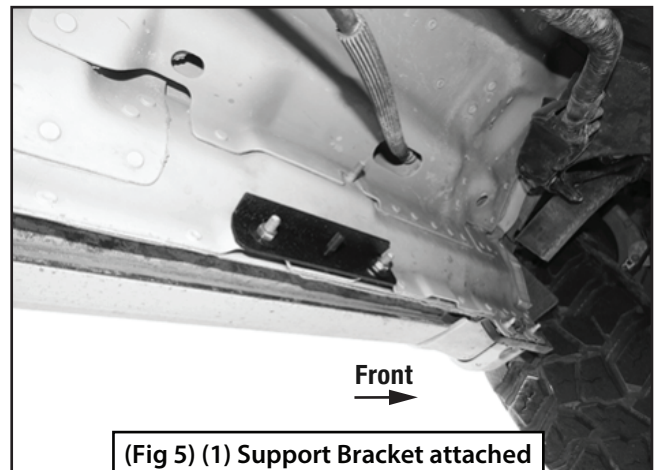

(Fig 5) (1) Support Bracket attached to the front mounting location

STEP 4

Select (1) Front Mounting Bracket (Fig 6). Attach the Bracket to the upper stud in the rocker panel and Support Bracket with (2) 8mm Flat Washers, and (2) 8mm Nylon Lock Nuts (Fig 6). **DO NOT** tighten hardware.

Driver/Left Side Installation Pictured

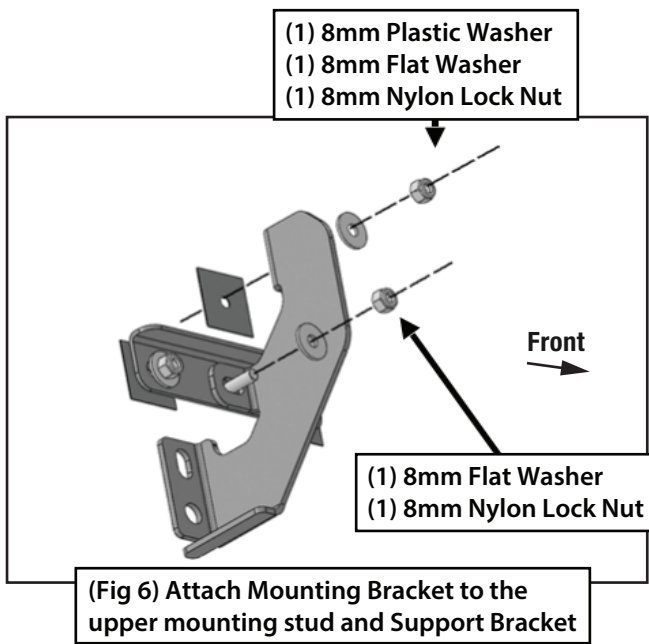

STEP 5

Repeat **STEPS 2 - 4** to attach (2) Center/Rear Mounting Brackets and (2) Support Brackets to the center and rear mounting location.

STEP 6

Select the Driver/Left TYGER LanderX. Attach the TYGER LanderX to the (3) Mounting Brackets with (6) 8mm Combo Bolts (Fig 7). **DO NOT** tighten hardware.

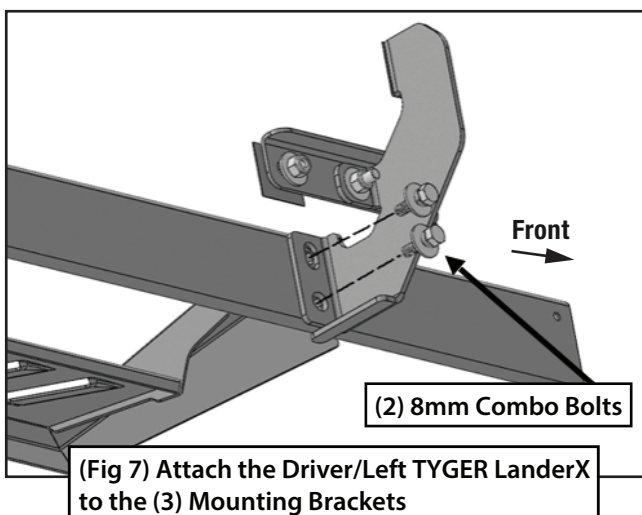
Driver/Left Side Installation Pictured

STEP 7

Level and adjust the TYGER LanderX, then tighten all hardware.

STEP 8

Repeat **STEPS 1-7** to attach the Passenger/Right TYGER LanderX.

STEP 9

Do periodic inspections to the installation to make sure that all hardware is secure and tight.