



TYGER LanderX

TG-LX3F82448

BEFORE INSTALLATION

READ INSTRUCTIONS CAREFULLY BEFORE STARTING INSTALLATION. REMOVE CONTENTS FROM BOX AND VERIFY ALL PARTS ARE PRESENT. FAILURE TO IDENTIFY DAMAGE BEFORE INSTALLATION COULD LEAD TO A REJECTION OF ANY CLAIM. IF MISSING PARTS OR ANY DAMAGE FOUND, PLEASE TAKE A PICTURE FOR THE CLAIM PURPOSE. TO FILE YOUR CLAIM, PLEASE VISIT: WWW.TYGERAUTO.COM/CONTACT

TORQUE VALUES

Fastener Size	Class 8.8 Torque (ft-lbs)	Class 10.9 Torque (ft-lbs)
6mm	6-7	6-7
8mm	15-16	22-23
10mm	31-32	44-45
12mm	54-55	78-79
14mm	87-88	125-126

- x1** Driver/Left TYGER LanderX
- x1** Passenger/Right TYGER LanderX
- x1** Driver/Left Front Mounting Bracket (A)
- x2** Driver/Left Center/Rear Mounting Brackets (B)
- x1** Passenger/Right Front Mounting Bracket (C)
- x2** Passenger/Right Center/Rear Mounting Brackets (D)
- x12** 10-1.5mm x 25mm Hex Bolts
- x12** 10mm Lock Washers
- x12** 10mm x 27mm OD x 3mm Flat Washers
- x12** 8mm x 25mm Combo Bolts

Parts List

Reference the letters printed on the brackets to determine mounting locations

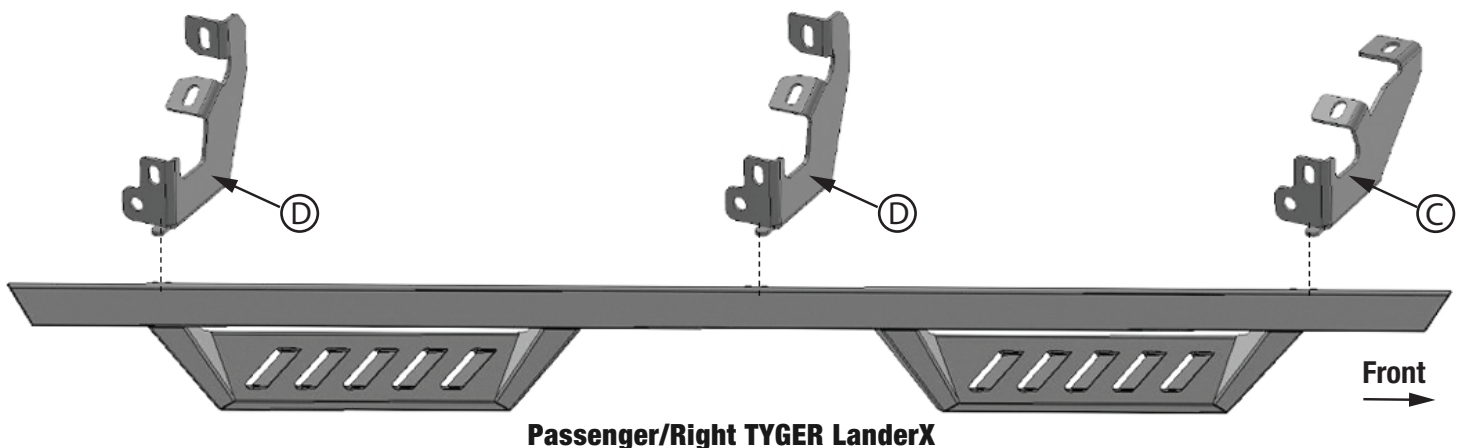
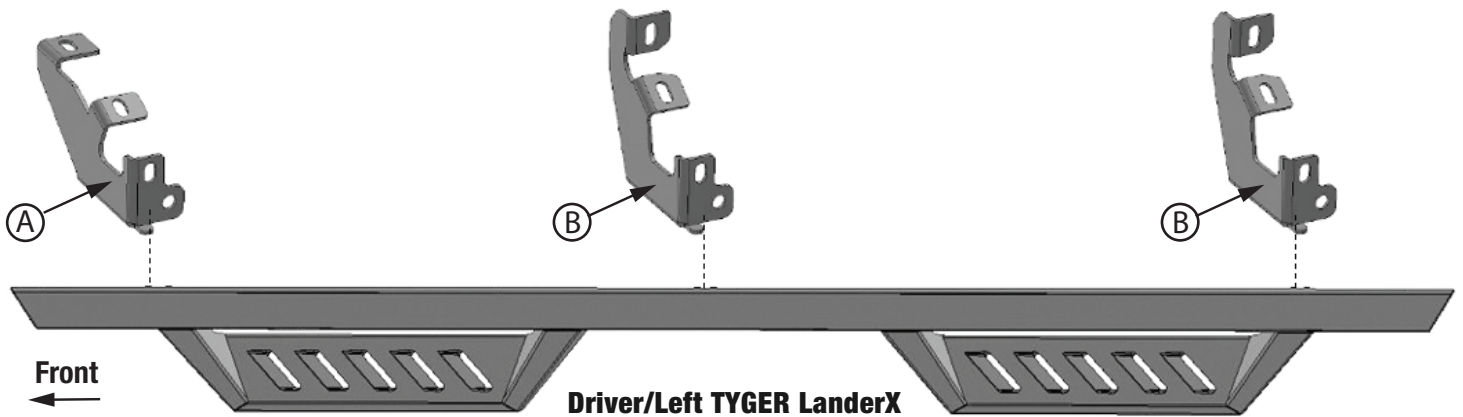

Bottom View

ATTENTION: Refer to the **D** or **P** labelling on the tubes to determine the Driver or Passenger side steps.

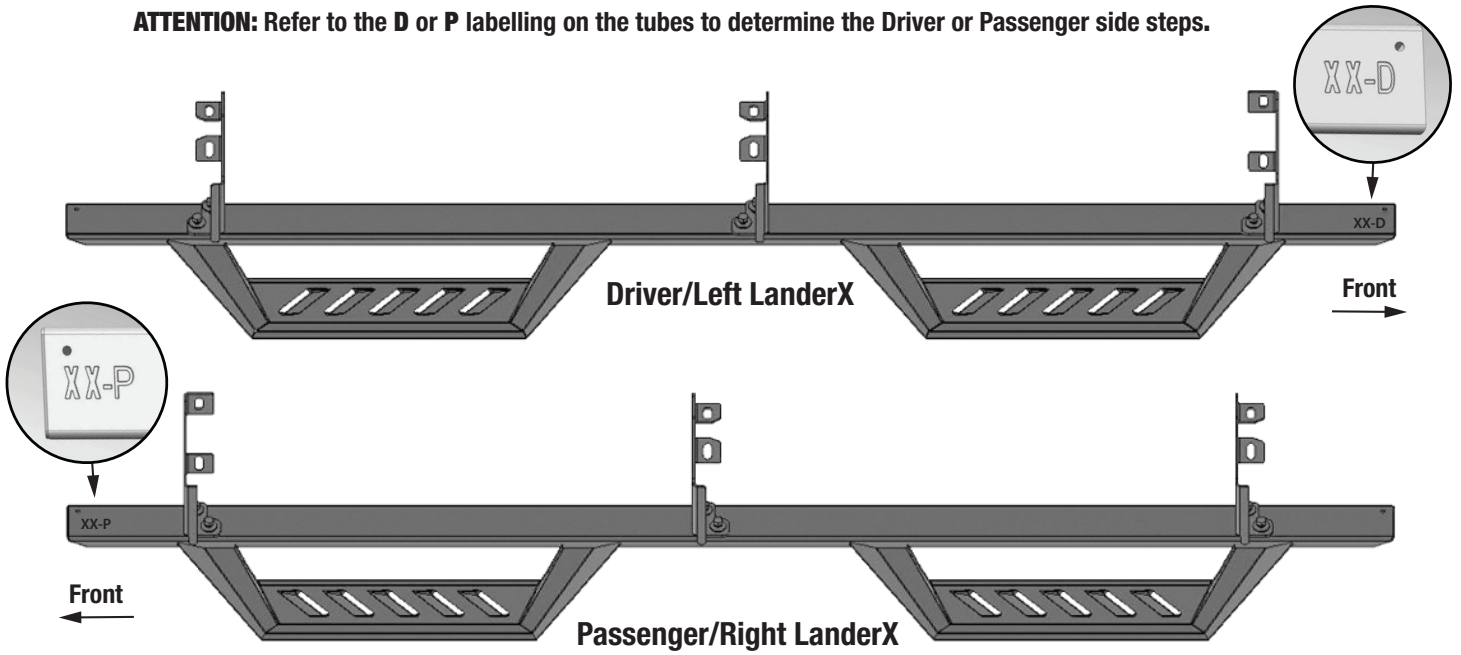

PROCEDURE:

REMOVE CONTENTS FROM BOX. VERIFY ALL PARTS ARE PRESENT. READ INSTRUCTIONS CAREFULLY BEFORE STARTING INSTALLATION.

STEP 1

Starting installation under the driver/left side inner rocker panel. Locate the threaded mounting holes in the rocker panel toward the front wheel opening (Fig 1). Remove the plastic plugs covering the mounting holes. Select the Driver/Left Front Mounting Bracket (A) (Fig 2). Attach Bracket to driver/left front location with (2) 10mm x 30mm Hex Bolts, (2) 10mm Lock Washers and (2) 10mm Flat Washers (Figs 2 & 3). DO NOT fully tighten hardware.

Driver/left side Installation Pictured

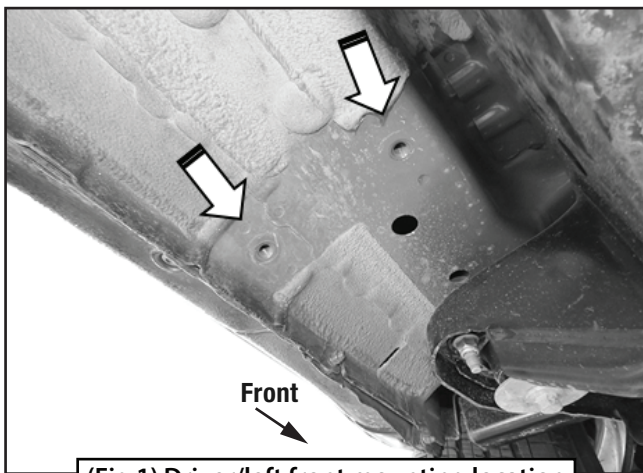

(Fig 1) Driver/left front mounting location

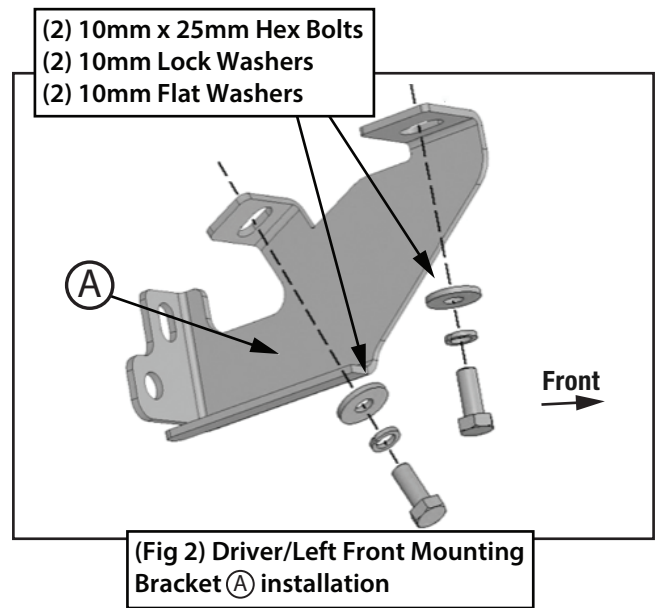

(Fig 2) Driver/Left Front Mounting Bracket (A) installation

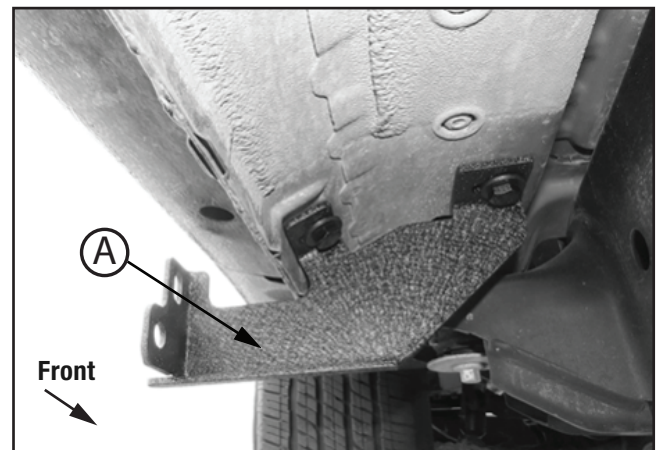

(Fig 3) Driver/Left Front Mounting Bracket (A) attached

STEP 2

Move to the center of the vehicle and locate the threaded mounting holes (Fig 4). Select (1) Driver/Left Center/Rear Mounting Bracket (B) (Fig 5). Attach the Bracket to the threaded holes with the included (2) 10mm x 25mm Hex Bolts, (2) 10mm Lock Washers and (2) 10mm Flat Washers (Figs 5 & 6). DO NOT fully tighten hardware.

Driver/left side Installation Pictured

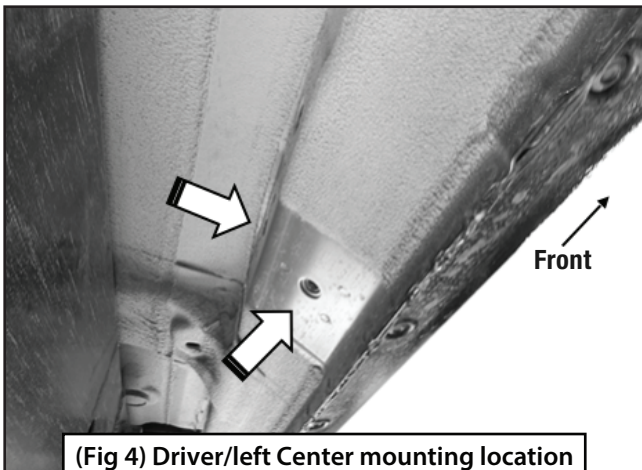

(Fig 4) Driver/left Center mounting location

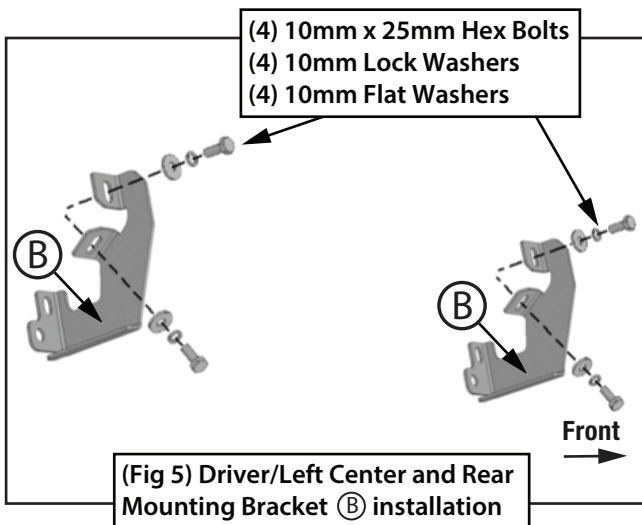

(Fig 5) Driver/Left Center and Rear Mounting Bracket (B) installation

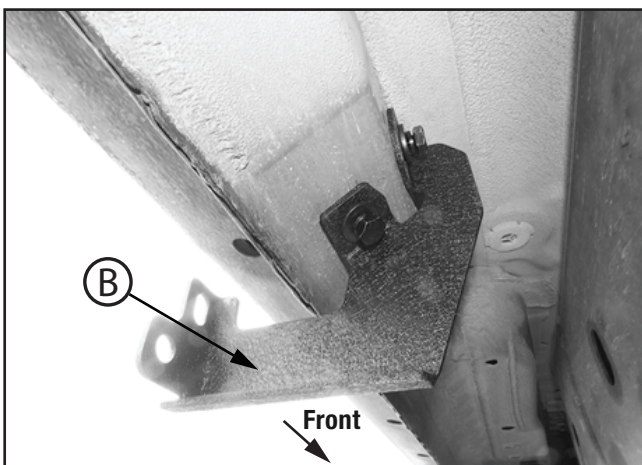

(Fig 6) Driver/Left Center Mounting Bracket (B) installed

STEP 3

Move to the last threaded holes closest to the rear wheel opening (Fig7). Select the remaining Driver/Left Center/Rear Mounting Bracket (B) (Fig 5). Repeat **STEP 2** to attach the Rear Mounting Bracket (Figs 5 & 8). DO NOT fully tighten hardware.

Driver/left side Installation Pictured

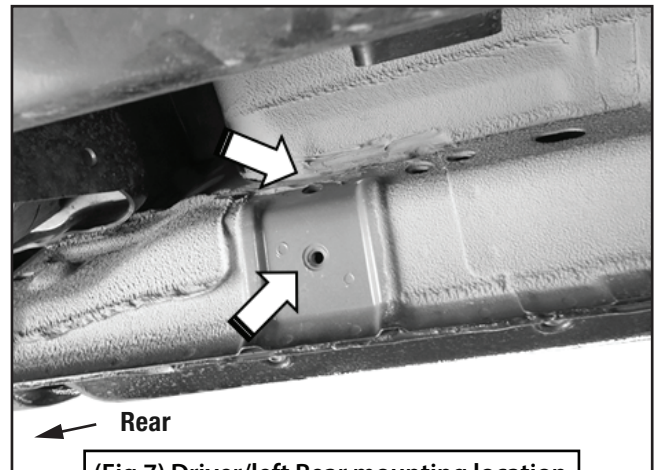

(Fig 7) Driver/left Rear mounting location

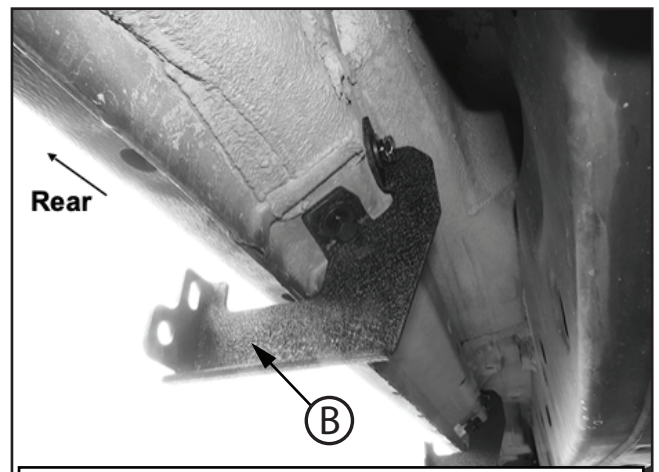

(Fig 8) Driver/left Rear Mounting Bracket (B) installed

STEP 4

Carefully unwrap the TYGER LanderX. Select the Driver/Left TYGER LanderX. Line up the TYGER LanderX with the (3) Mounting Brackets. Attach the TYGER LanderX to the Brackets with the included (6) 8mm x 25mm Combo Hex Bolts (Figs 9-13).

Driver/left side Installation Pictured

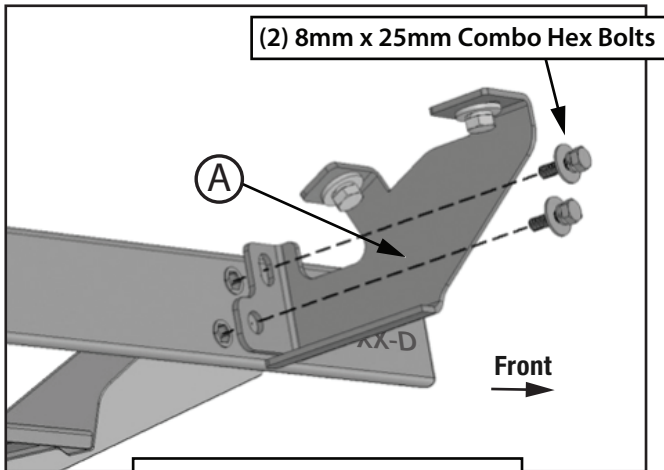

(Fig 9) Attach Driver/Left TYGER LanderX to Front Bracket

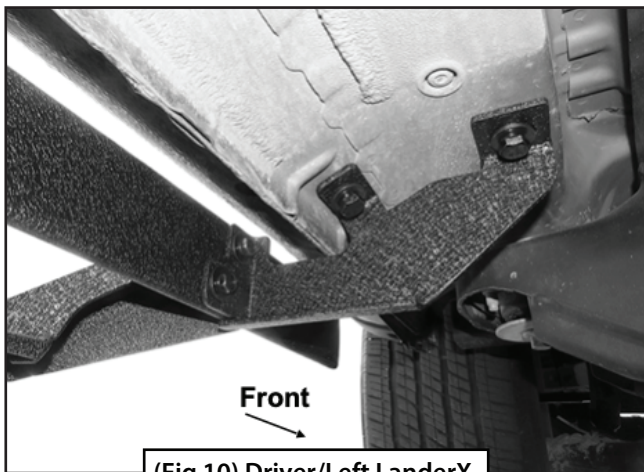

(Fig 10) Driver/Left LanderX attached to Front Bracket (A)

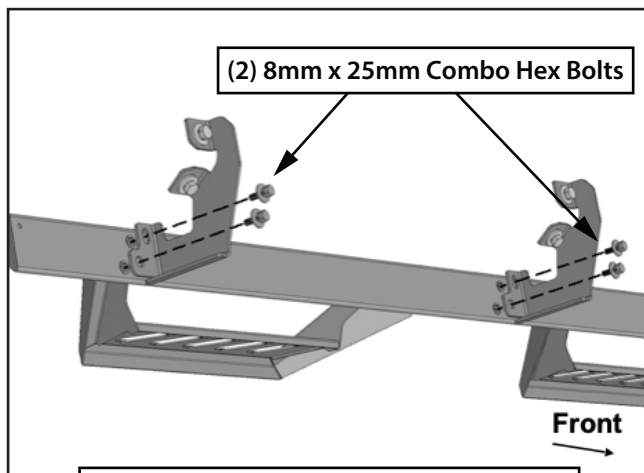

(Fig 11) Attach Driver/Left TYGER LanderX to Center and Rear Brackets (B)

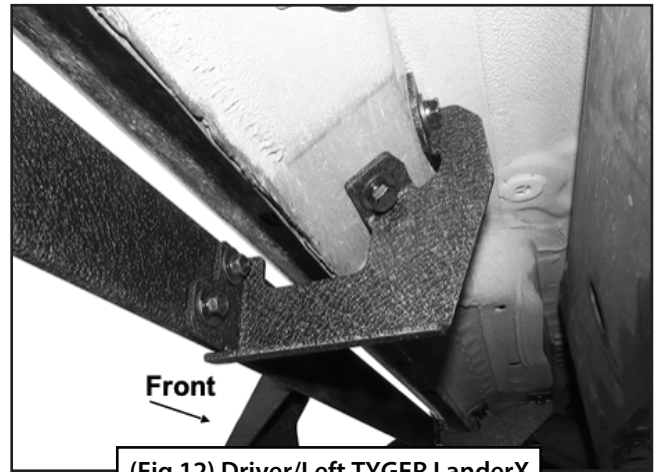

(Fig 12) Driver/Left TYGER LanderX attached to Center Bracket (B)



(Fig 13) Driver/Left TYGER LanderX attached to Rear Bracket (B)

STEP 5

Level and adjust the TYGER LanderX and tighten all hardware.

STEP 6

Repeat **STEPS 1-5** to install the Passenger/Right TYGER LanderX "P".

STEP 7

Do periodic inspections to the installation to make sure that all hardware is secure and tight.