



TYGER LanderX

TG-LX3F84628

BEFORE INSTALLATION

READ INSTRUCTIONS CAREFULLY BEFORE STARTING INSTALLATION. REMOVE CONTENTS FROM BOX AND VERIFY ALL PARTS ARE PRESENT. FAILURE TO IDENTIFY DAMAGE BEFORE INSTALLATION COULD LEAD TO A REJECTION OF ANY CLAIM. IF MISSING PARTS OR ANY DAMAGE FOUND, PLEASE TAKE A PICTURE FOR THE CLAIM PURPOSE. TO FILE YOUR CLAIM, PLEASE VISIT: WWW.TYGERAUTO.COM/CONTACT

TORQUE VALUES

Fastener Size	Class 8.8 Torque (ft-lbs)	Class 10.9 Torque (ft-lbs)
6mm	6-7	6-7
8mm	15-16	22-23
10mm	31-32	44-45
12mm	54-55	78-79
14mm	87-88	125-126

- x1** Driver/Left TYGER LanderX **D**
- x3** Mounting Brackets **[B]**
- x12** 10mm Lock Washers
- x6** 10mm Clip Nuts
- x1** Passenger/Right TYGER LanderX **P**
- x12** 10-1.5mm x 30mm Hex Bolts
- x18** 10mm x 27mm x 3mm Flat Washers
- x3** Mounting Brackets **[A]**
- x12** 8-1.25mm x 25mm Combo Bolts
- x6** 10mm Hex Nuts

[Parts List](#)

Top View

ATTENTION: Refer to **D** and **P** labelling on the side of the tubes to determine Driver and Passenger LanderX

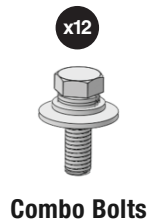
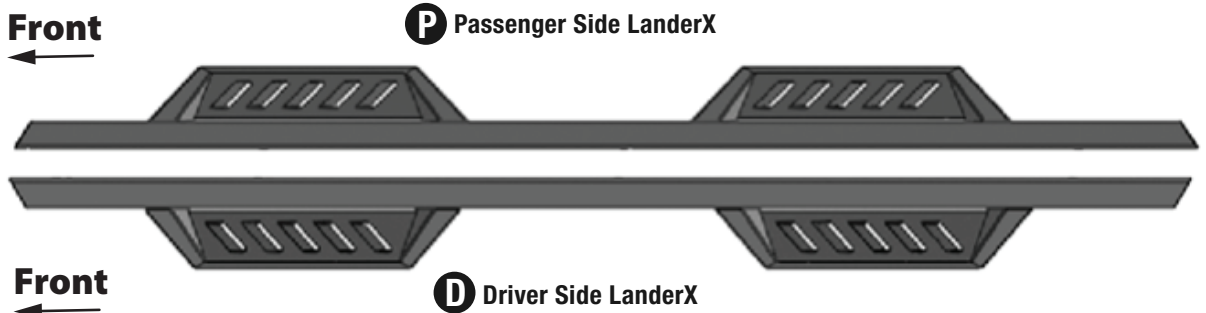
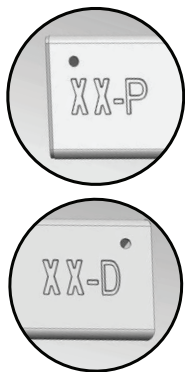

Reference the letters printed on the brackets to determine mounting locations

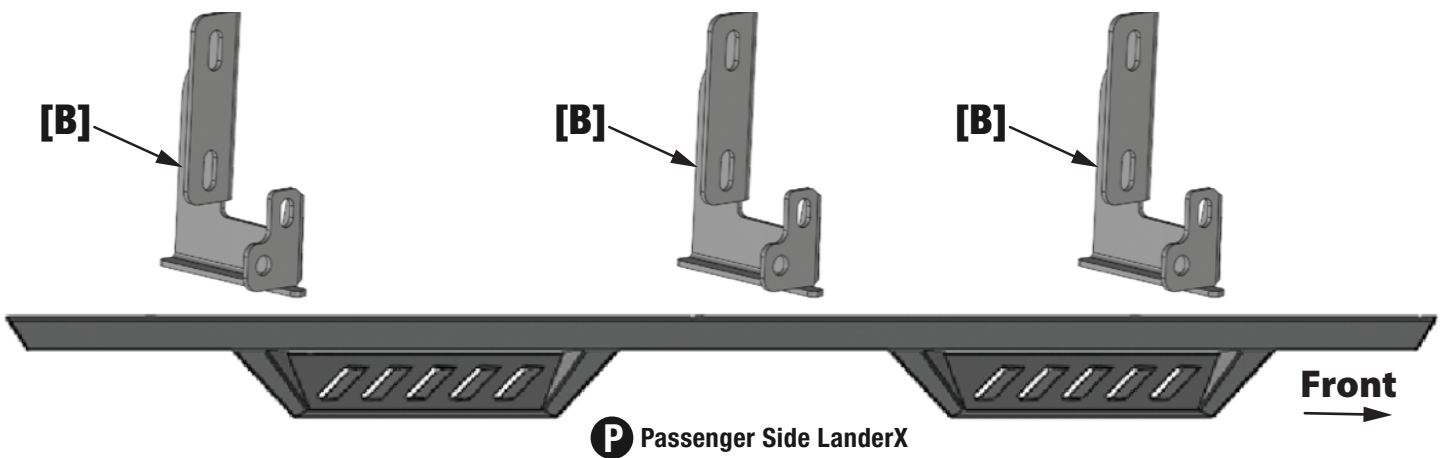
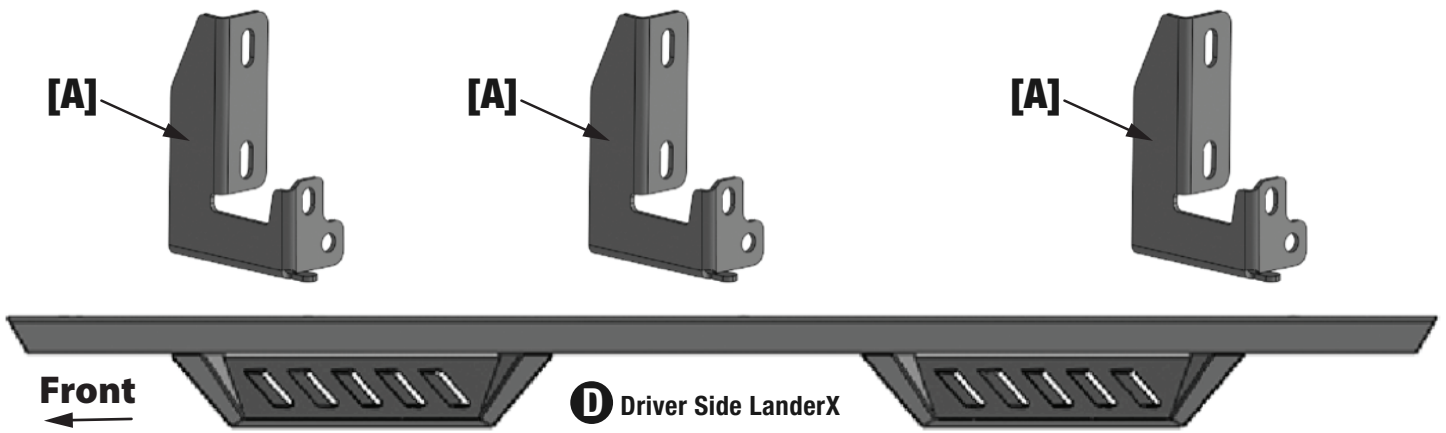

Bottom View

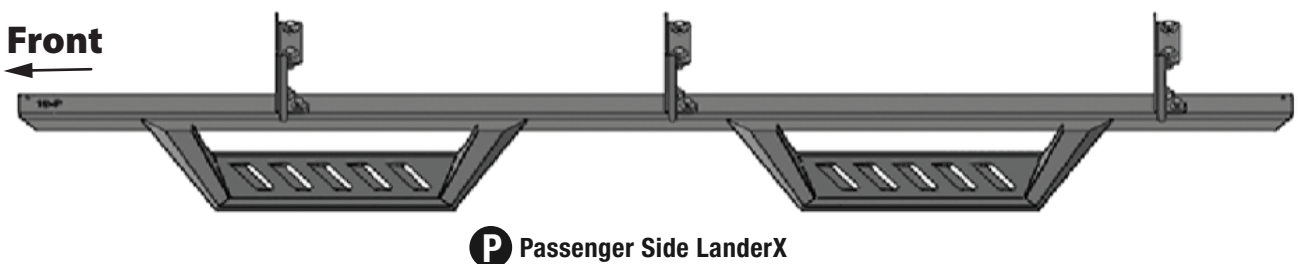
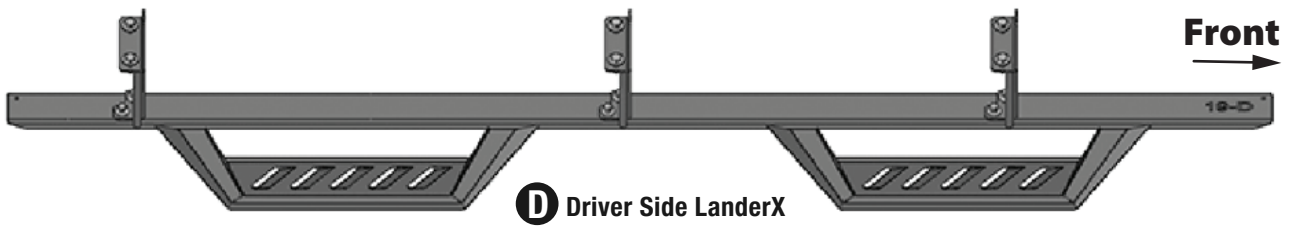

TOOLS REQUIRED

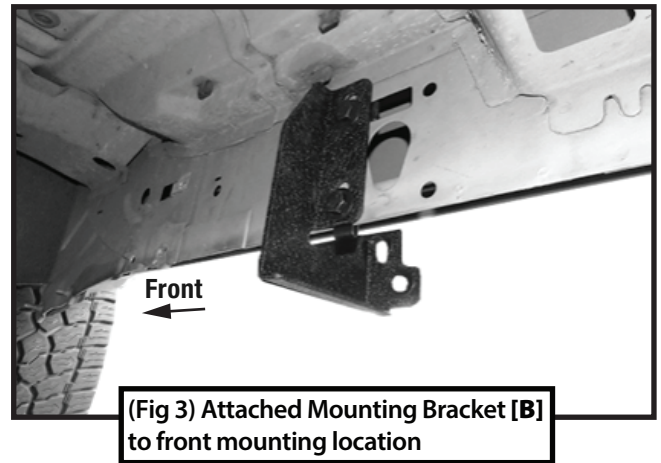
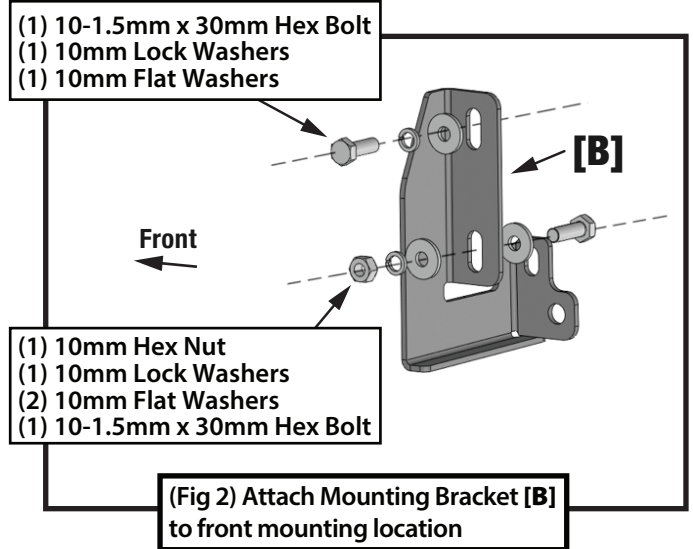
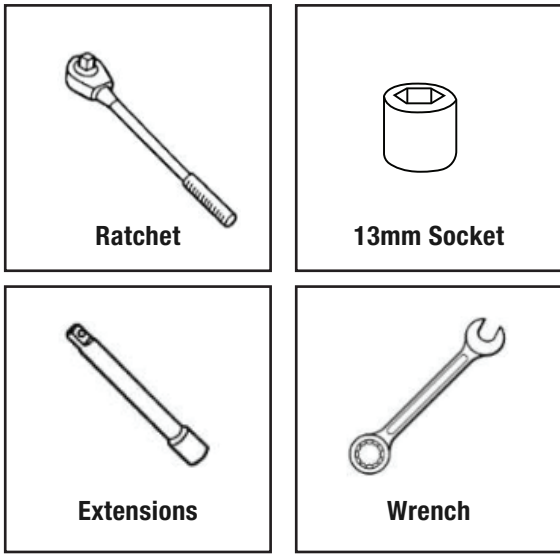

STEP 1 MOUNTING BRACKETS

Follow (Fig 1 – 7) to attach the Mounting Brackets to the Passenger Side.

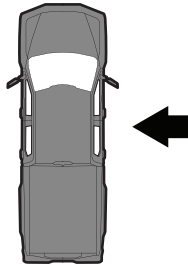

Passenger-side Front Mounting Area

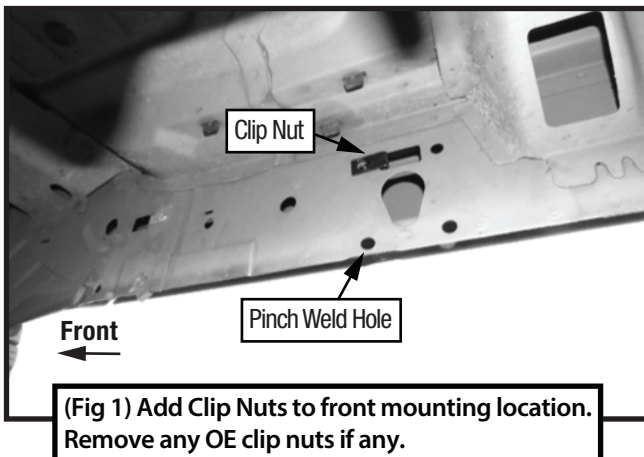

Passenger-side Center Mounting Area

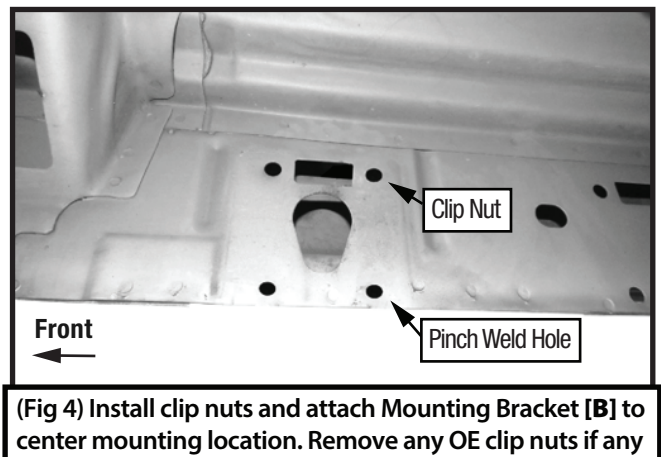

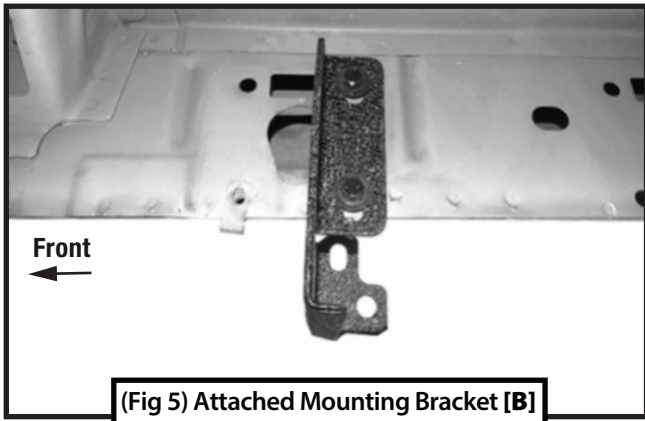

(Fig 5) Attached Mounting Bracket [B] to center mounting location



Passenger-side Rear Mounting Area

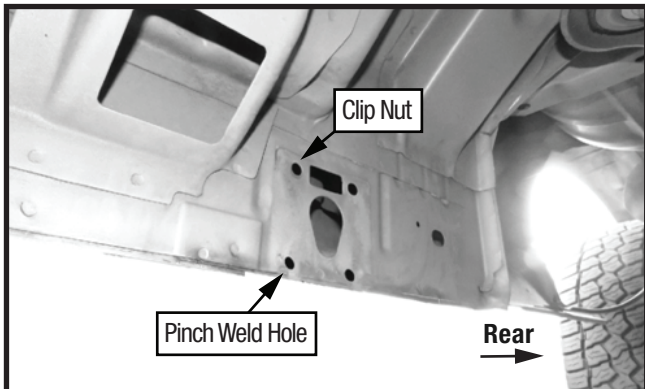

(Fig 6) Install clip nuts and attach Mounting Bracket [B] to rear mounting location. Remove any OE clip nuts if any.

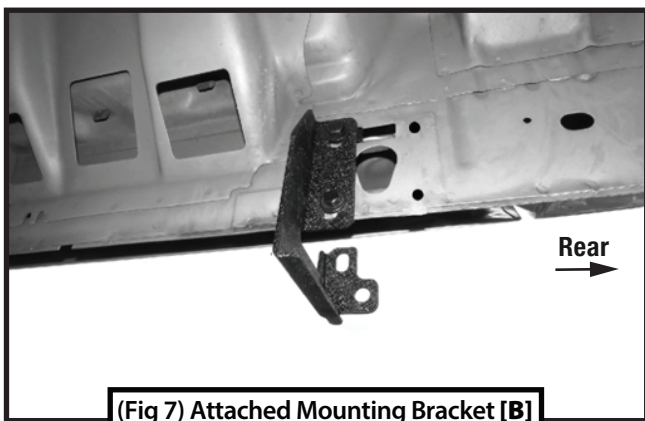

(Fig 7) Attached Mounting Bracket [B] to rear mounting location

STEP 2 MOUNTING RUNNING BOARD

Follow (Fig 8) to install the running board.

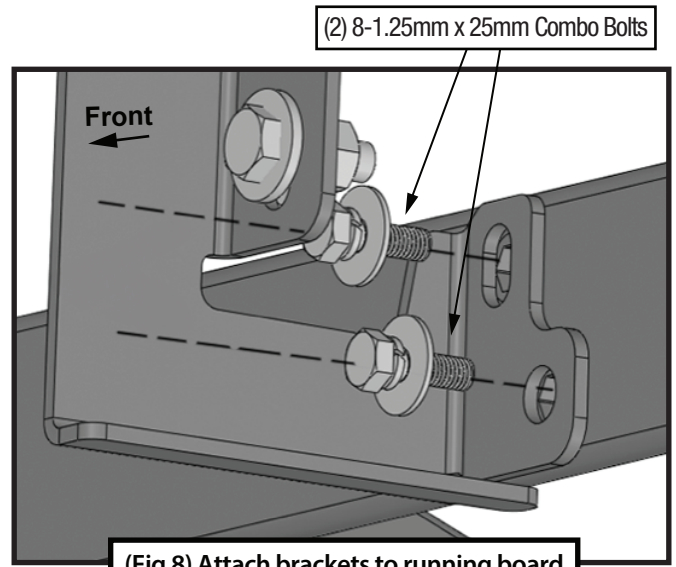

(Fig 8) Attach brackets to running board

STEP 3 DRIVER SIDE

Repeat **STEPS 1-2** for driver side installation. Use Mounting Brackets [A] instead of [B].

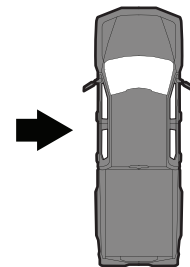

STEP 4

Installation is complete. Do periodic inspections to the installation to make sure that all hardware is secure and tight.

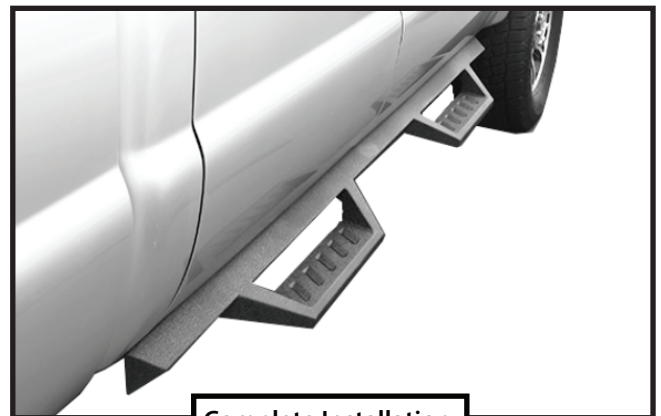

Complete Installation