



## TYGER LanderX

TG-LX3J82378

Scan to Download the Latest Digital Version



### BEFORE INSTALLATION

READ INSTRUCTIONS CAREFULLY BEFORE STARTING INSTALLATION. REMOVE CONTENTS FROM BOX AND VERIFY ALL PARTS ARE PRESENT. FAILURE TO IDENTIFY DAMAGE BEFORE INSTALLATION COULD LEAD TO A REJECTION OF ANY CLAIM. IF MISSING PARTS OR ANY DAMAGE FOUND, PLEASE TAKE A PICTURE FOR THE CLAIM PURPOSE. TO FILE YOUR CLAIM, PLEASE VISIT: [WWW.TYGERAUTO.COM/CONTACT](http://WWW.TYGERAUTO.COM/CONTACT)

### TORQUE VALUES

Fastener Size	Class 8.8 Torque (ft-lbs)	Class 10.9 Torque (ft-lbs)
6mm	6-7	6-7
8mm	15-16	22-23
10mm	31-32	44-45
12mm	54-55	78-79
14mm	87-88	125-126

- x1** Driver/Left TYGER LanderX **[D]**
- x1** Passenger/Right TYGER LanderX **[P]**
- x1** Driver/Left Front Bracket **[A]**
- x1** Driver/Left Center Bracket **[B]**
- x1** Driver/Left Rear Bracket **[C]**
- x1** Driver/Left Front Support Bracket **[G]**
- x1** Driver/Left Center Support Bracket **[H]**
- x1** Driver/Left Rear Support Bracket **[I]**
- x1** Passenger/Right Front Bracket **[D]**
- x1** Passenger/Right Center Bracket **[E]**
- x1** Passenger/Right Rear Bracket **[F]**
- x1** Passenger/Right Front Support Bracket **[J]**
- x1** Passenger/Right Center Support Bracket **[K]**
- x1** Passenger/Right Rear Support Bracket **[L]**
- x6** 8-1.25mm x 35mm Hex Bolts
- x6** 10-1.5mm x 30mm Hex Bolts
- x12** 8-1.25mm x 25mm Combo Hex Bolts
- x24** 6mm x 22mm x 2mm Flat Washers
- x6** 8mm x 28mm x 3mm Flat Washers
- x12** 10mm x 24mm x 2.2mm Flat Washers
- x12** 6mm Nylon Lock Nuts
- x6** 10mm Nylon Lock Nuts

Parts List

### Top View

**ATTENTION:** Refer to **[D]** and **[P]** labelling on the side of the tubes to determine Driver and Passenger LanderX

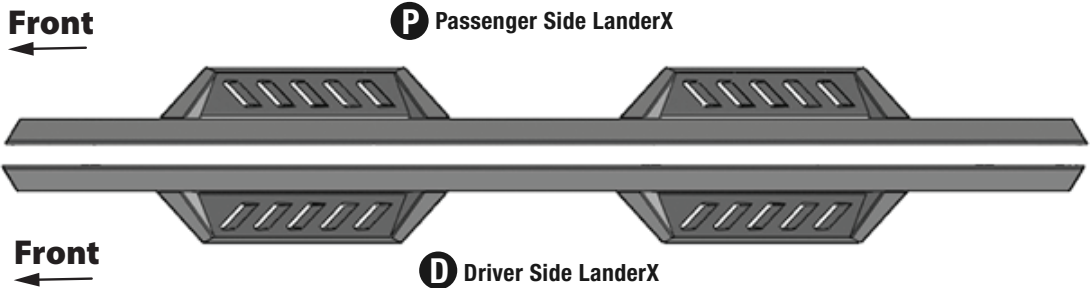
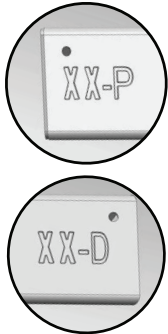

- x1** **[G]** Driver Side Front Support Bracket
- x1** **[H]** Driver Side Center Support Bracket
- x1** **[I]** Driver Side Rear Support Bracket
- x1** **[J]** Passenger Side Front Support Bracket
- x1** **[K]** Passenger Side Center Support Bracket
- x1** **[L]** Passenger Side Rear Support Bracket
- x1** **[A]** Driver Side Front Bracket
- x1** **[B]** Driver Side Center Bracket
- x1** **[C]** Driver Side Rear Bracket
- x1** **[D]** Passenger Side Front Bracket
- x1** **[E]** Passenger Side Center Bracket
- x1** **[F]** Passenger Side Rear Bracket
- x12** Hex Bolt 6-1.00mm x 25mm Hex Bolts
- x6** Hex Bolt 8-1.25mm x 35mm Hex Bolts
- x6** Hex Bolt 10-1.5mm x 30mm Hex Bolts
- x12** Combo Hex Bolts 8-1.25mm x 25mm Combo Hex Bolts
- x24** Flat Washer 6mm x 22mm x 2mm Flat Washers
- x6** Flat Washer 8mm x 28mm x 3mm Flat Washers
- x12** Flat Washer 10mm x 24mm x 2.2mm Flat Washers
- x12** Nylon Lock Nut 6mm Nylon Lock Nuts
- x6** Nylon Lock Nut 10mm Nylon Lock Nuts
- x6** Lock Nut 8mm Lock Washers

Reference the letters printed on the brackets to determine mounting locations

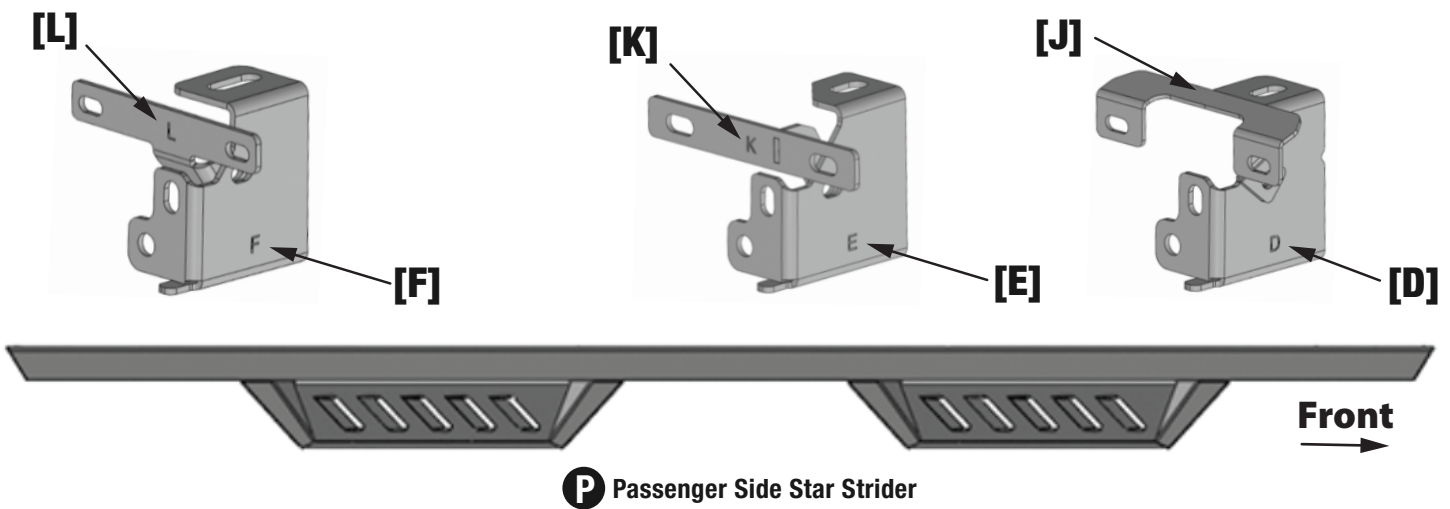
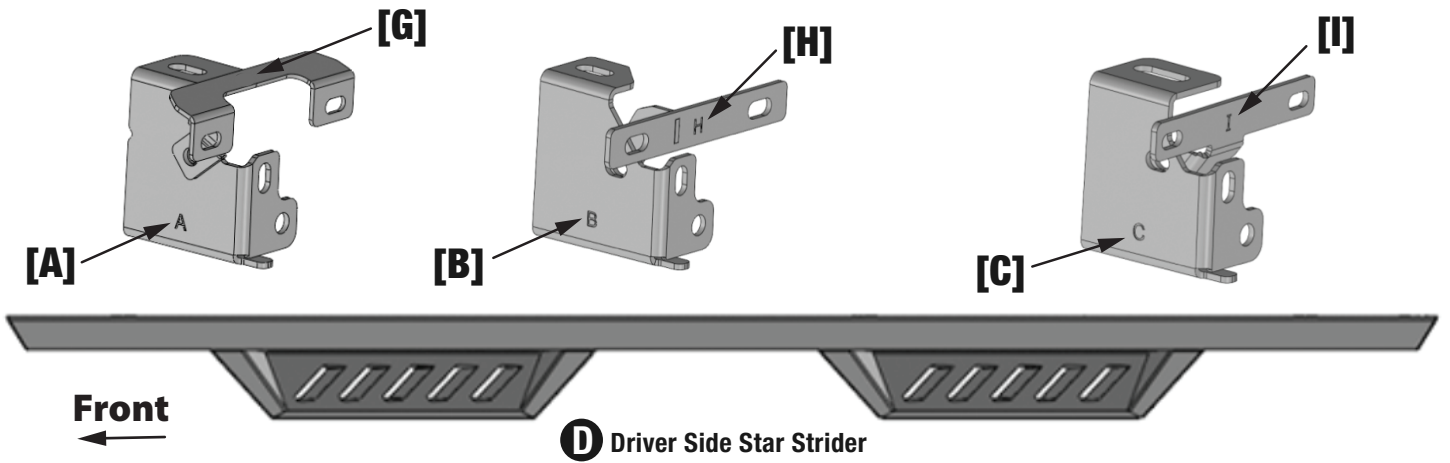

**Bottom View**

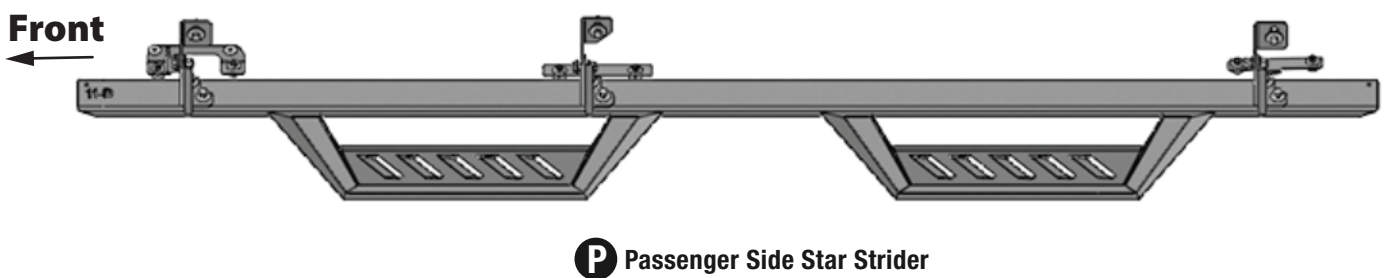
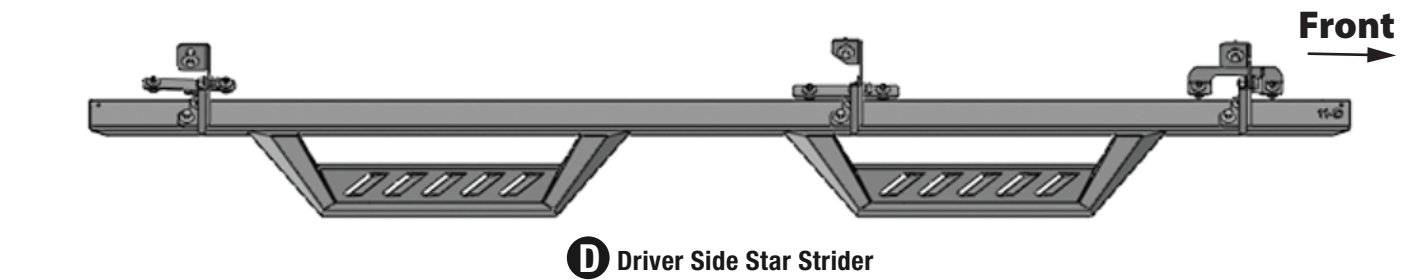

## TOOLS REQUIRED

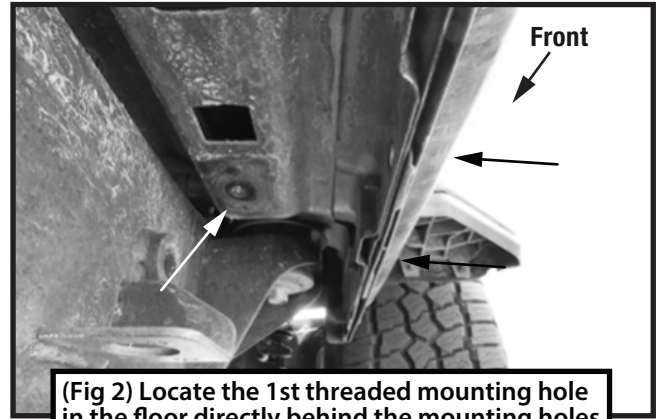
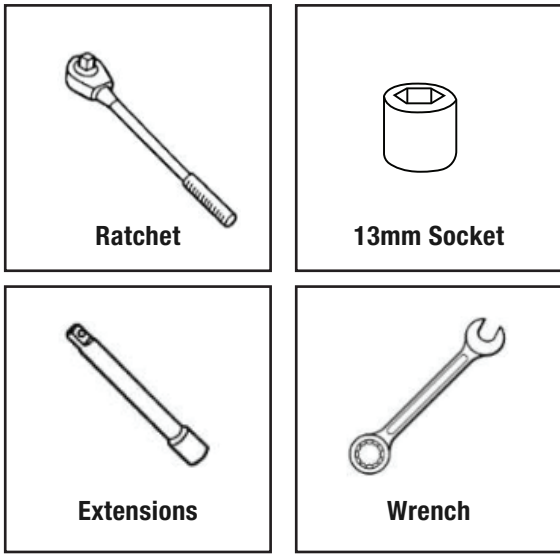

(Fig 2) Locate the 1st threaded mounting hole in the floor directly behind the mounting holes in the pinch weld

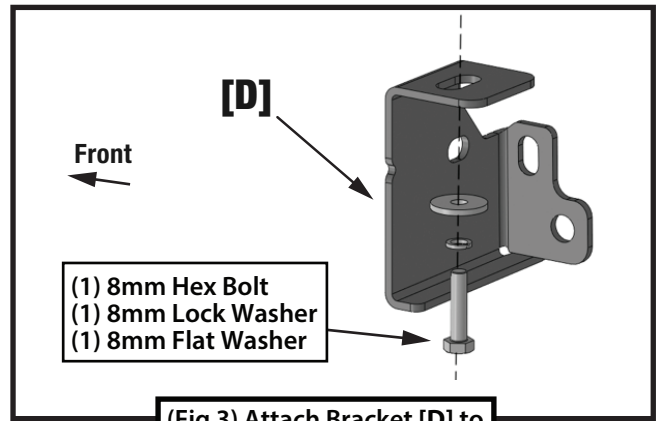

(Fig 3) Attach Bracket [D] to mounting location in floor

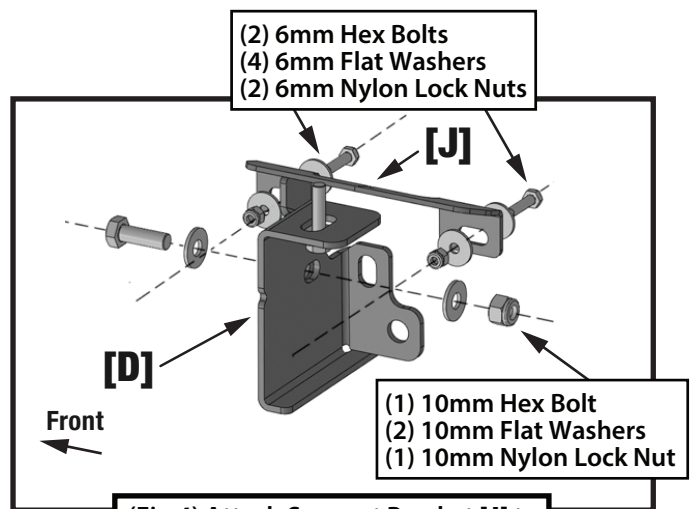

(Fig 4) Attach Support Bracket [J] to pinch weld mounting locations and Bracket [D]

## STEP 1 MOUNTING BRACKETS

Start installation on the Passenger Side. Locate the (4) pairs of mounting holes along the pinch weld (Fig 1).

**NOTE:** Installation will use the 1st, 2nd and 4th mounting locations.

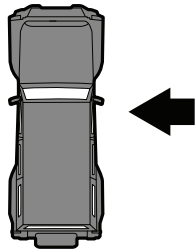

### Passenger-side Front Mounting Area

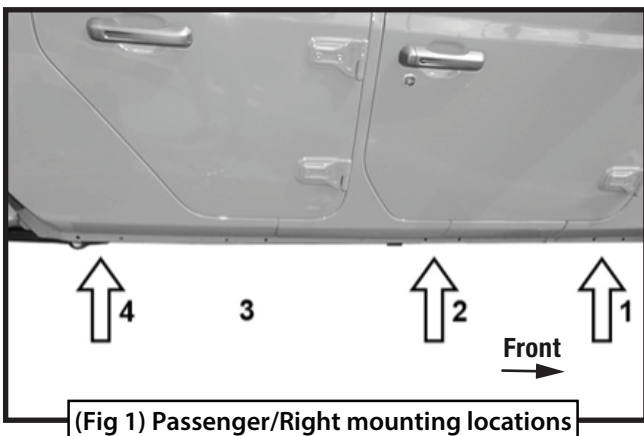

(Fig 1) Passenger/Right mounting locations

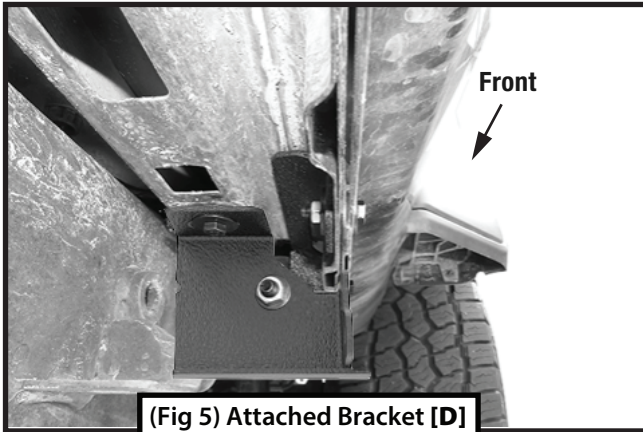

(Fig 5) Attached Bracket [D] and Support Bracket [J]

**Passenger-side Center Mounting Area**

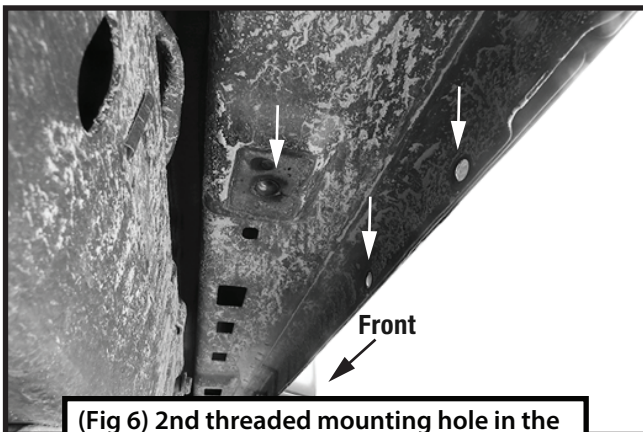

(Fig 6) 2nd threaded mounting hole in the floor and mounting holes in the pinch weld

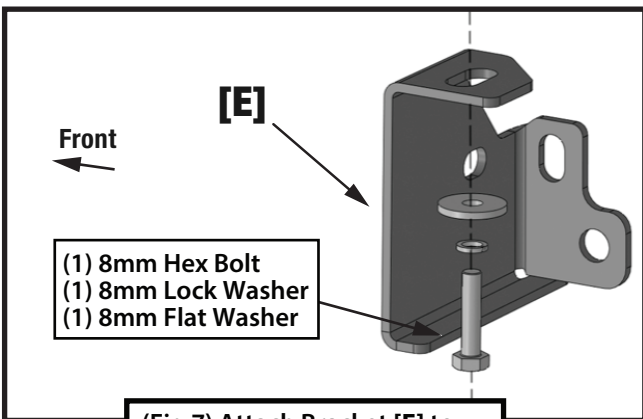

(Fig 7) Attach Bracket [E] to mounting location in the floor

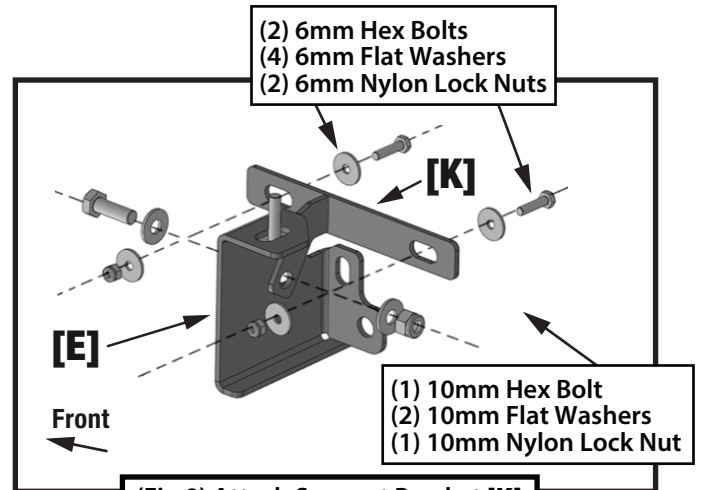

(Fig 8) Attach Support Bracket [K] to pinch weld mounting locations and Bracket [E]

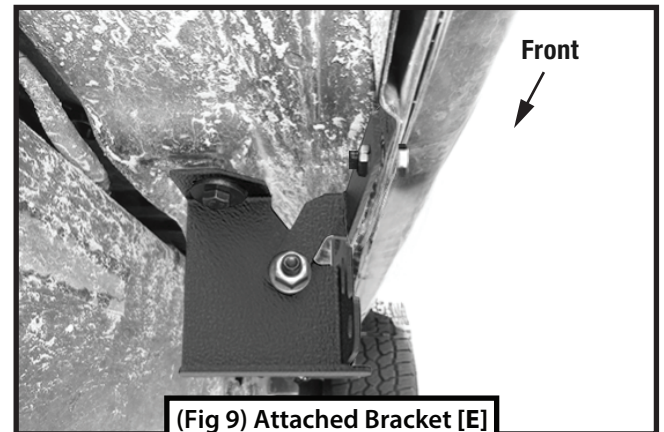

(Fig 9) Attached Bracket [E] and Support Bracket [K]

**Passenger-side Rear Mounting Area**

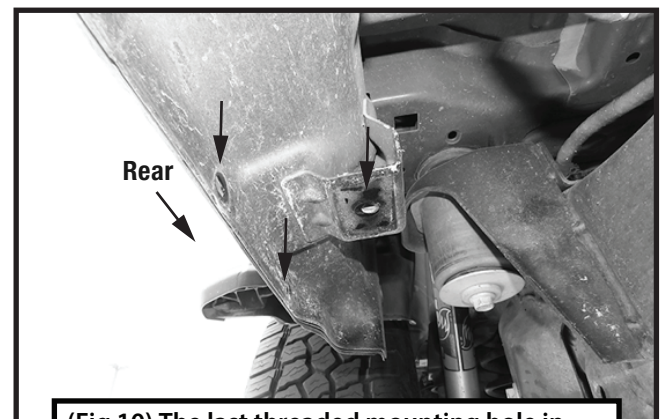

(Fig 10) The last threaded mounting hole in the floor and mounting holes in the pinch weld

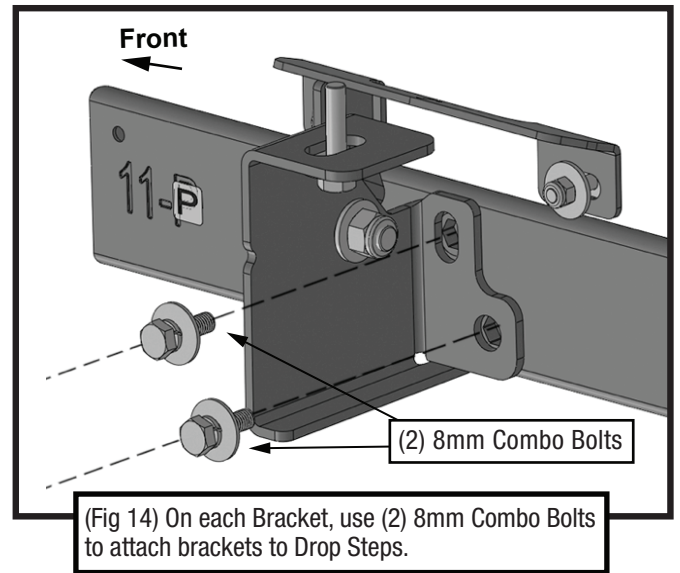
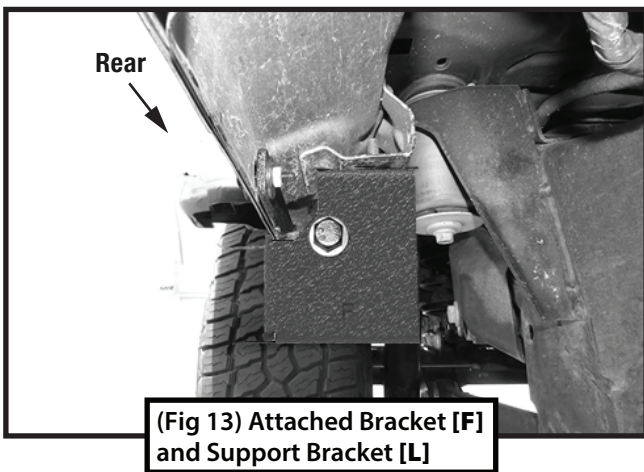
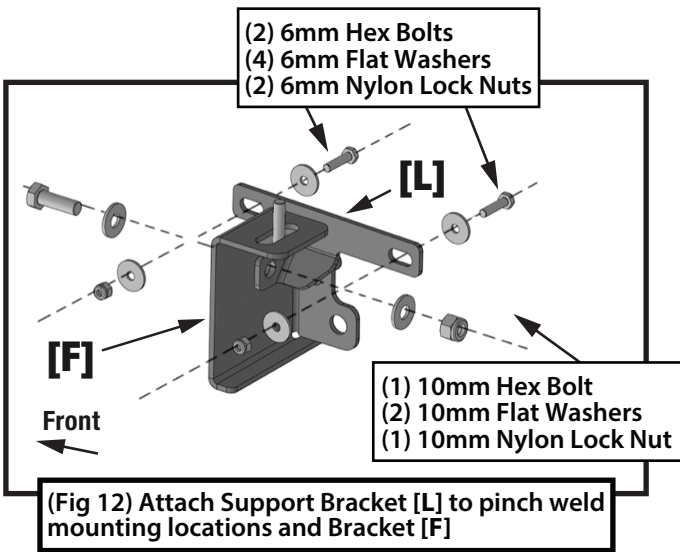
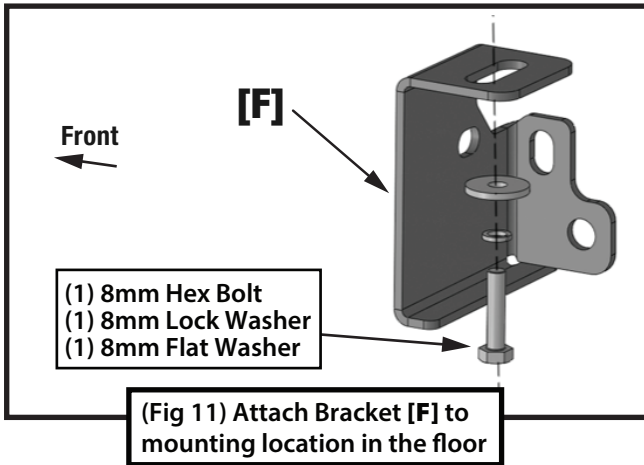

### STEP 3 DRIVER SIDE

Repeat **STEPS 1-2** for driver side installation.  
 Use Front Bracket [A] instead of [D];  
 Use Center Bracket [B] instead of [E];  
 Use Rear Bracket [C] instead of [F];  
 Use Front Support Bracket [G] instead of [J];  
 Use Center Support Bracket [H] instead of [K];  
 Use Rear Support Bracket [I] instead of [L];

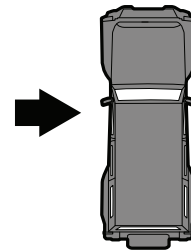

### STEP 4

Installation is complete. Do periodic inspections to the installation to make sure that all hardware is secure and tight.

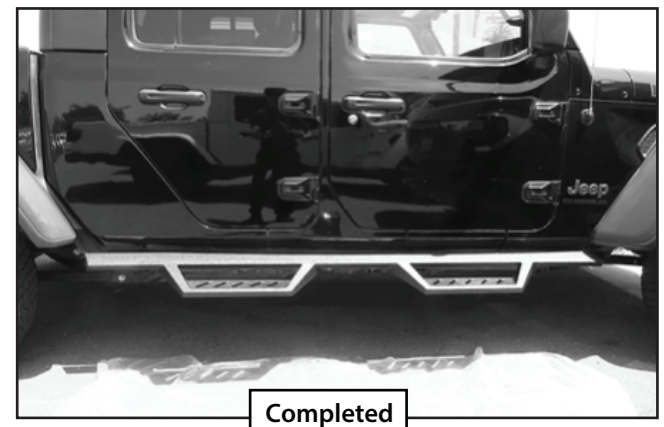

## STEP 2 MOUNTING RUNNING BOARDS

Follow Fig 14 to install the running board. Level and adjust the running board and tighten all hardware.