



TYGER LanderX

TG-LX3N83578

BEFORE INSTALLATION

READ INSTRUCTIONS CAREFULLY BEFORE STARTING INSTALLATION. REMOVE CONTENTS FROM BOX AND VERIFY ALL PARTS ARE PRESENT. FAILURE TO IDENTIFY DAMAGE BEFORE INSTALLATION COULD LEAD TO A REJECTION OF ANY CLAIM. IF MISSING PARTS OR ANY DAMAGE FOUND, PLEASE TAKE A PICTURE FOR THE CLAIM PURPOSE. TO FILE YOUR CLAIM, PLEASE VISIT: WWW.TYGERAUTO.COM/CONTACT

TORQUE VALUES

Fastener Size	Class 8.8 Torque (ft-lbs)	Class 10.9 Torque (ft-lbs)
6mm	6-7	6-7
8mm	15-16	22-23
10mm	31-32	44-45
12mm	54-55	78-79
14mm	87-88	125-126

x1 Driver/Left TYGER LanderX

x3 Mounting Brackets [B]

x12 8mm Lock Washers

x1 Passenger/Right TYGER LanderX

x6 8mm Nylon Lock Nuts

x12 8-1.25mm x 30mm Hex Bolts

x3 Mounting Brackets [A]

x12 8-1.25mm x 25mm Combo Bolts

x12 8mm x 24mm x 2mm Flat Washers

Parts List

Top View

ATTENTION: Refer to **D** and **P** labelling on the side of the tubes to determine Driver and Passenger LanderX

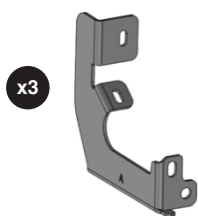
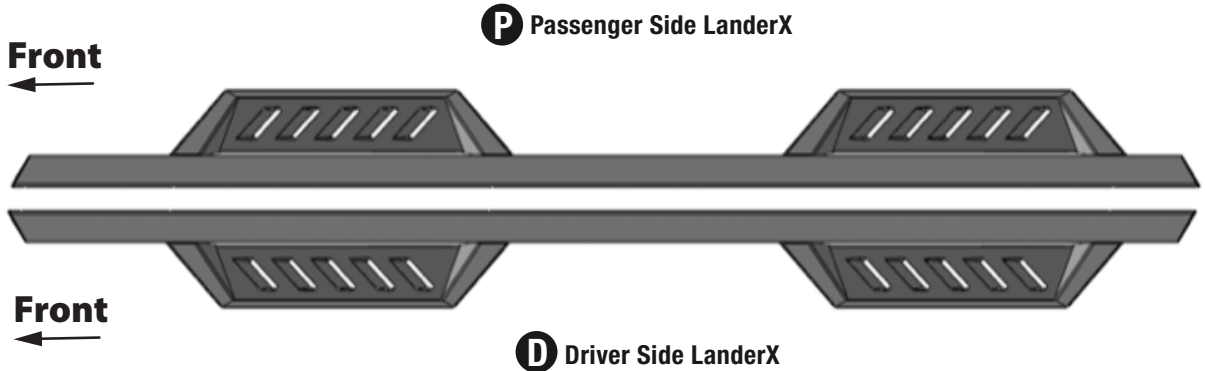
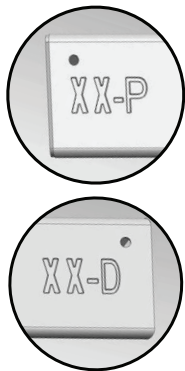

[A] Bracket



[B] Bracket



Hex Bolts



Combo Bolts



Flat Washer



Nylon Lock Nut



Lock Washer

Reference the letters printed on the brackets to determine mounting locations

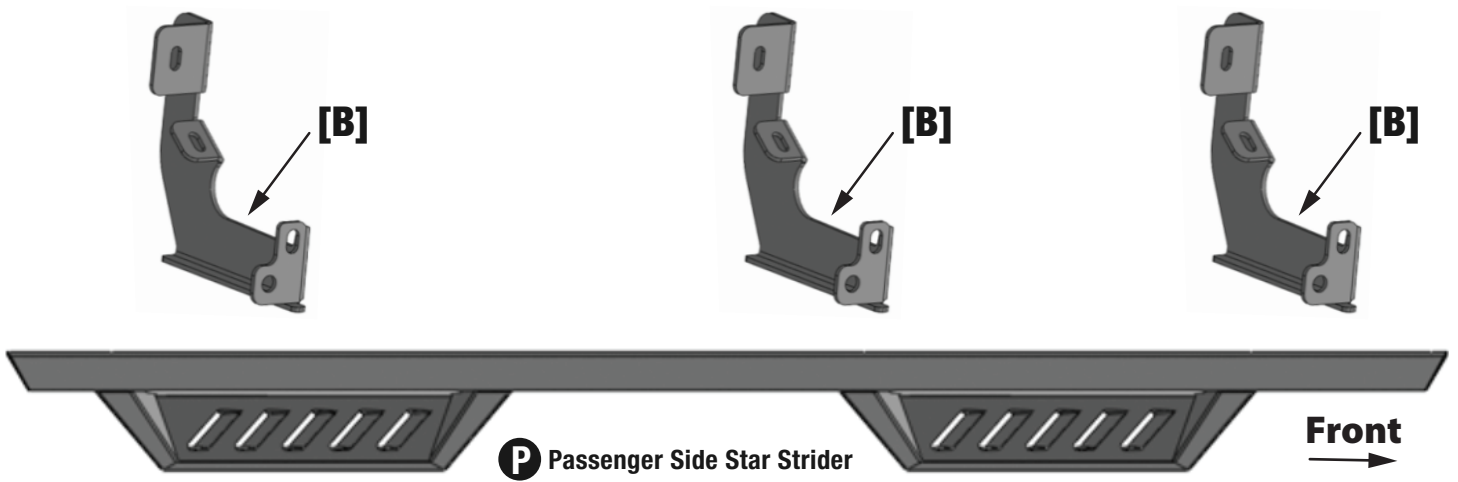
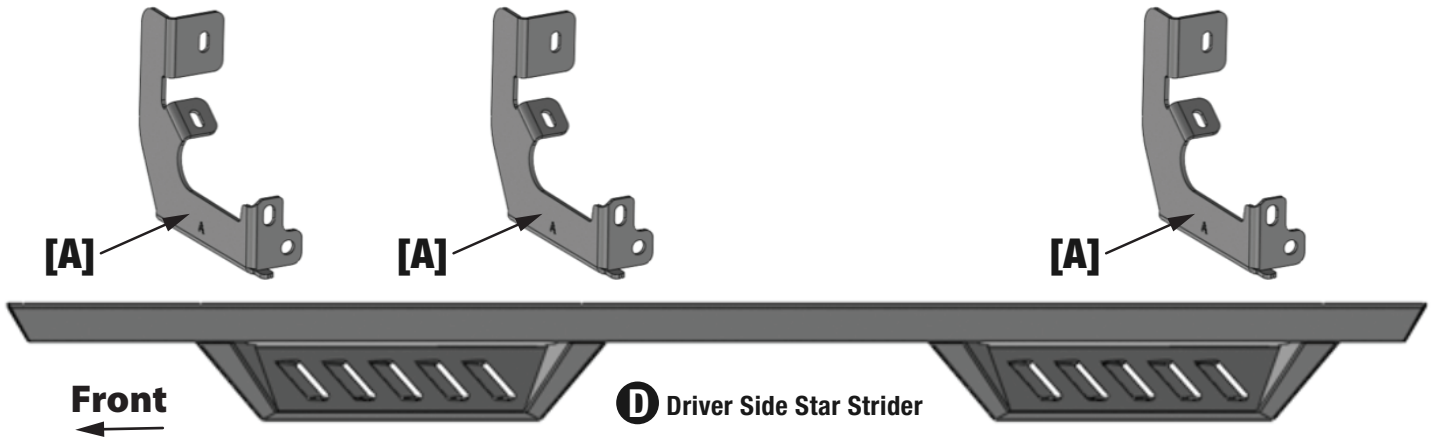

Bottom View

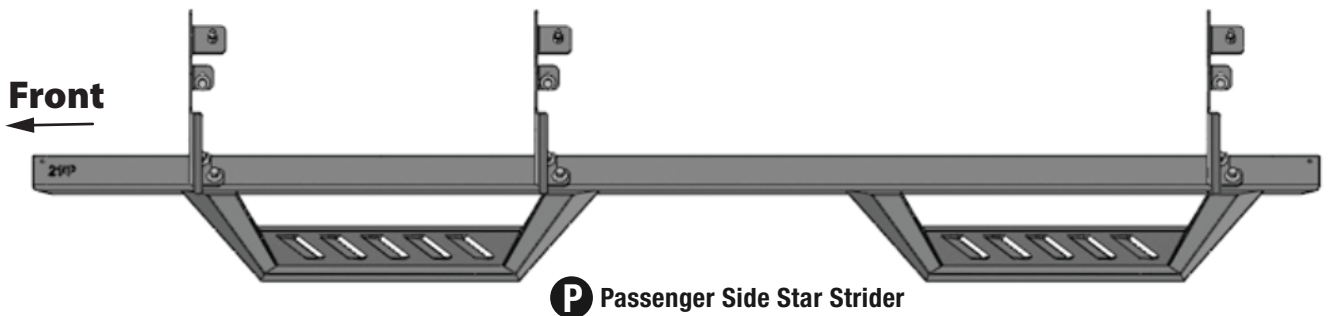
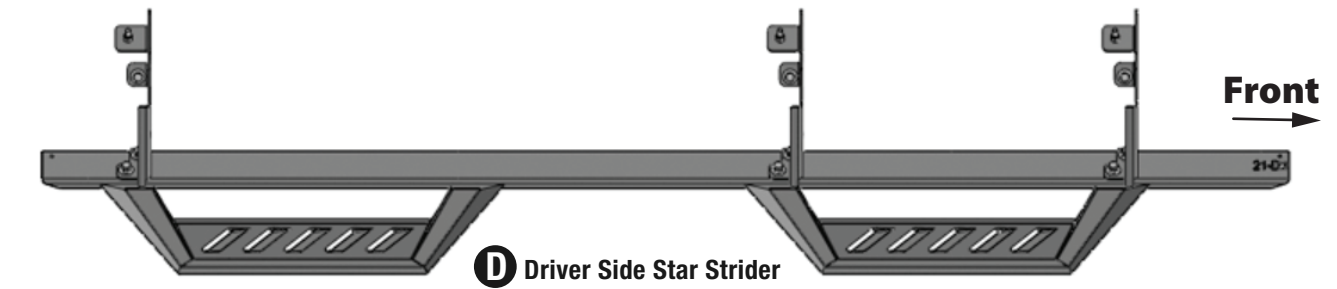

TOOLS REQUIRED

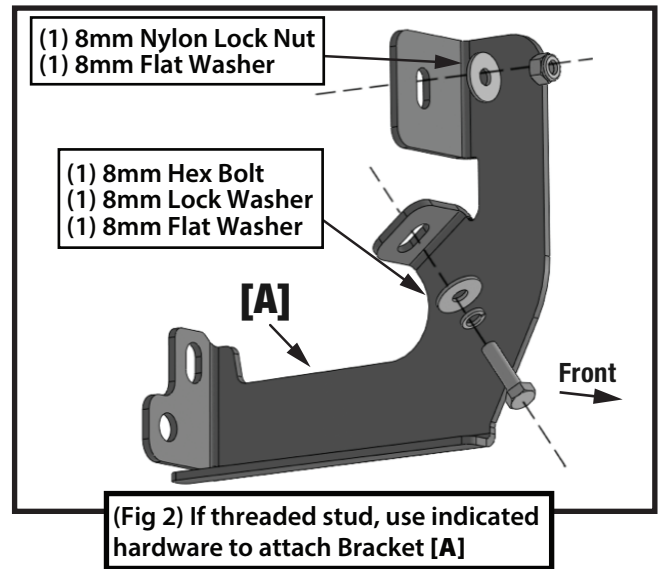
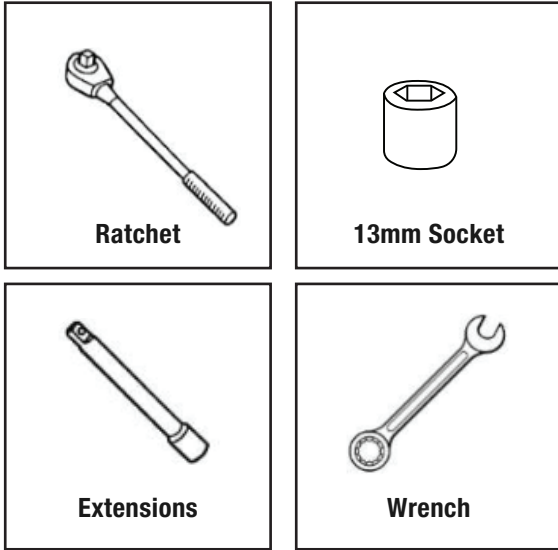

STEP 1 MOUNTING BRACKETS

Follow (Fig 1 – 9) to attach the Mounting Brackets to the Driver Side.

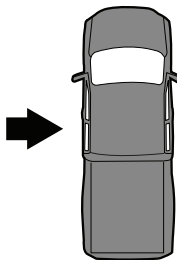

Driver-side Front Mounting Area

Models With Threaded Stud:

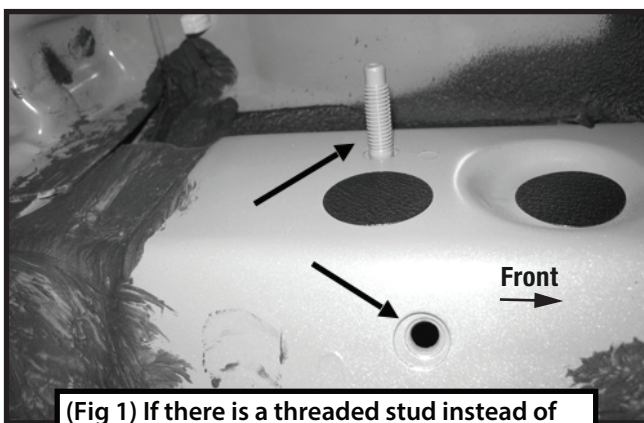

Models Without Threaded Stud:

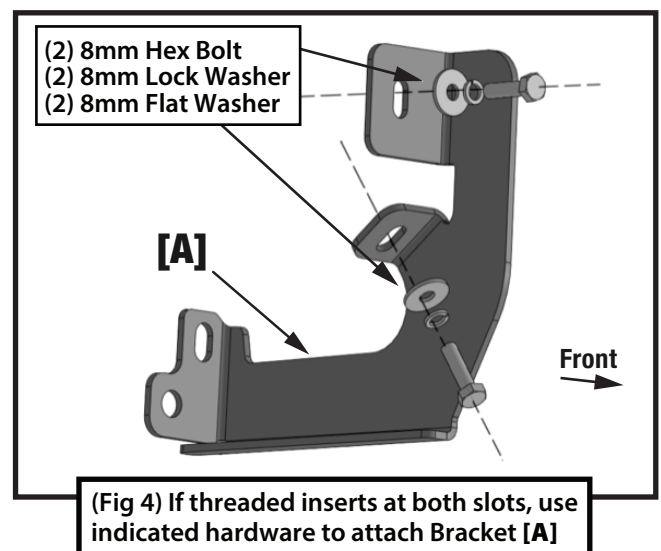
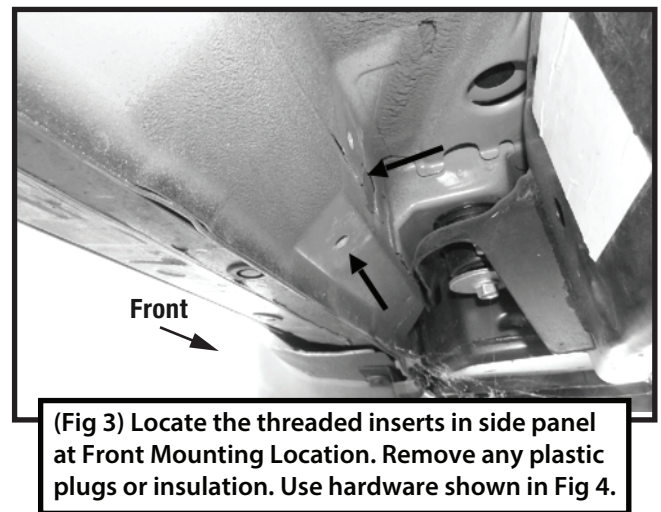

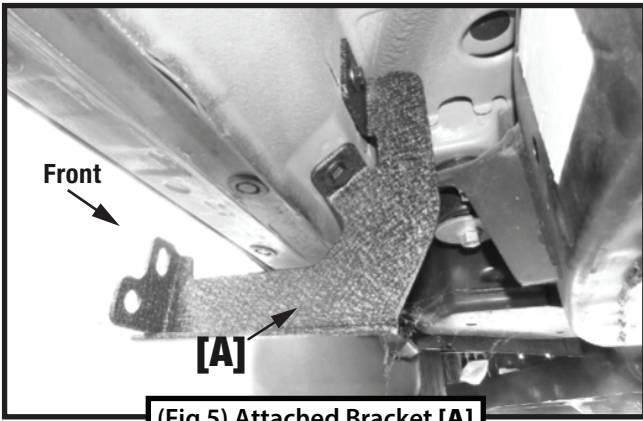

Driver-side Center Mounting Area

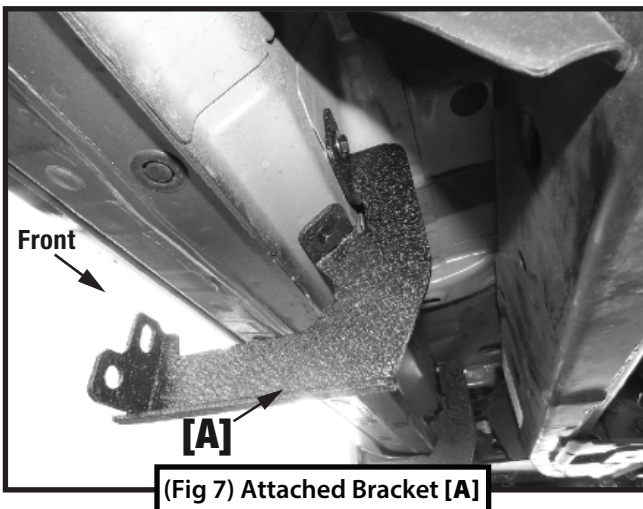
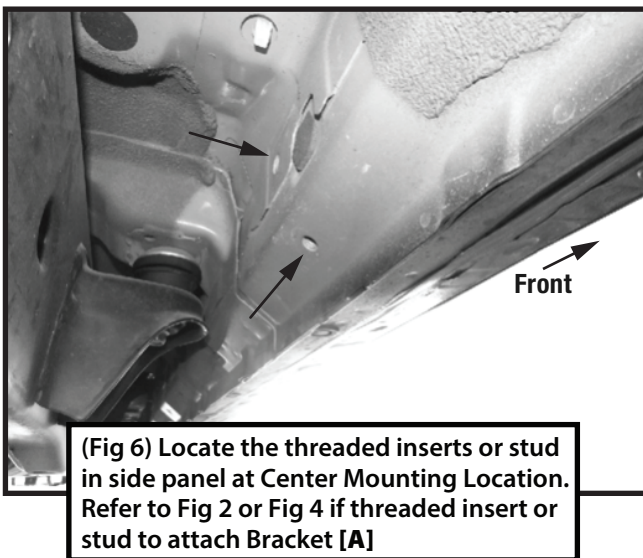

Driver-side Rear Mounting Area

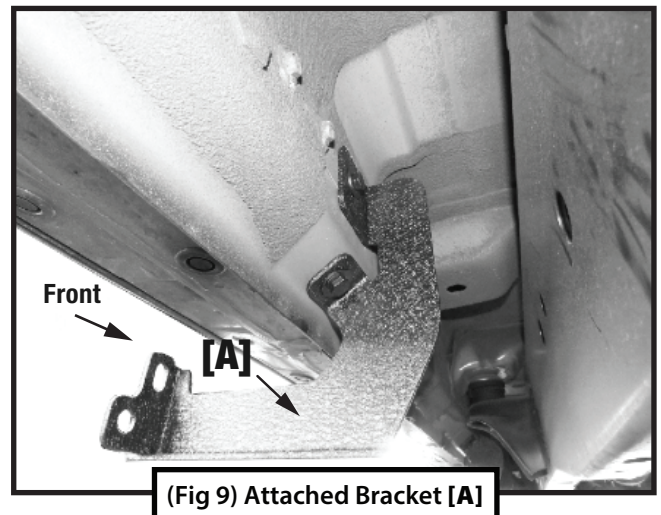
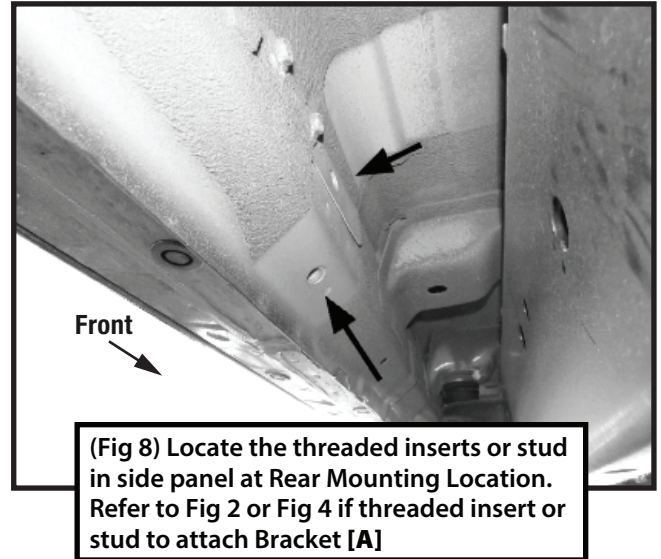

STEP 2 MOUNTING RUNNING BOARDS

Follow Fig 10 to install the running board. Level and adjust the running board and tighten all hardware.

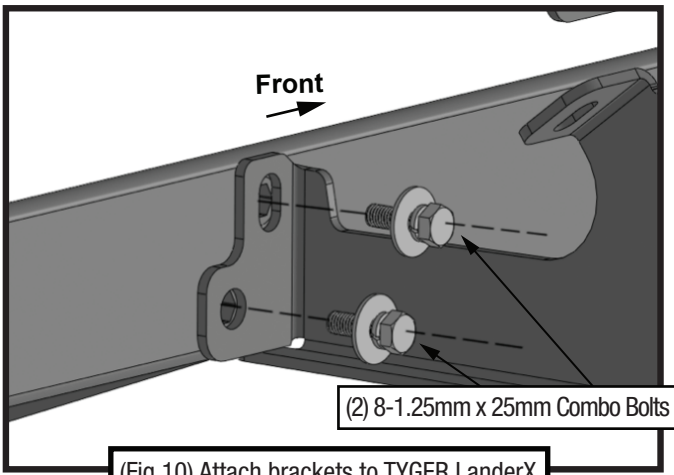

STEP 3 PASSENGER SIDE

Repeat **STEPS 1-2** for passenger side installation. Use Mounting Bracket **[B]** instead of **[A]**.

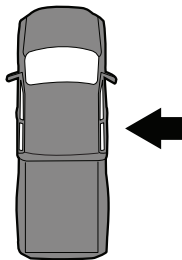

STEP 4

Installation is complete. Do periodic inspections to the installation to make sure that all hardware is secure and tight.

