



TYGER LanderX

TG-LX3T82338

BEFORE INSTALLATION

READ INSTRUCTIONS CAREFULLY BEFORE STARTING INSTALLATION. REMOVE CONTENTS FROM BOX AND VERIFY ALL PARTS ARE PRESENT. FAILURE TO IDENTIFY DAMAGE BEFORE INSTALLATION COULD LEAD TO A REJECTION OF ANY CLAIM. IF MISSING PARTS OR ANY DAMAGE FOUND, PLEASE TAKE A PICTURE FOR THE CLAIM PURPOSE. TO FILE YOUR CLAIM, PLEASE VISIT: WWW.TYGERAUTO.COM/CONTACT

TORQUE VALUES

Fastener Size	Class 8.8 Torque (ft-lbs)	Class 10.9 Torque (ft-lbs)
6mm	6-7	6-7
8mm	15-16	22-23
10mm	31-32	44-45
12mm	54-55	78-79
14mm	87-88	125-126

- x1** Driver/Left TYGER LanderX
- x1** Passenger/Right TYGER LanderX
- x1** Driver/Left Front Mounting Bracket (A)
- x1** Passenger/Right Front Mounting Bracket (C)
- x2** Driver/Left Center/Rear Mounting Brackets (B)
- x2** Passenger/Right Center/Rear Mounting Brackets (D)
- x12** 8mm Lock Washers
- x12** 8mm spacers
- x12** 8mm x 30mm Hex Bolts
- x12** 8mm x 25mm Combo Bolts

Parts List

Reference the letters printed on the brackets to determine mounting locations

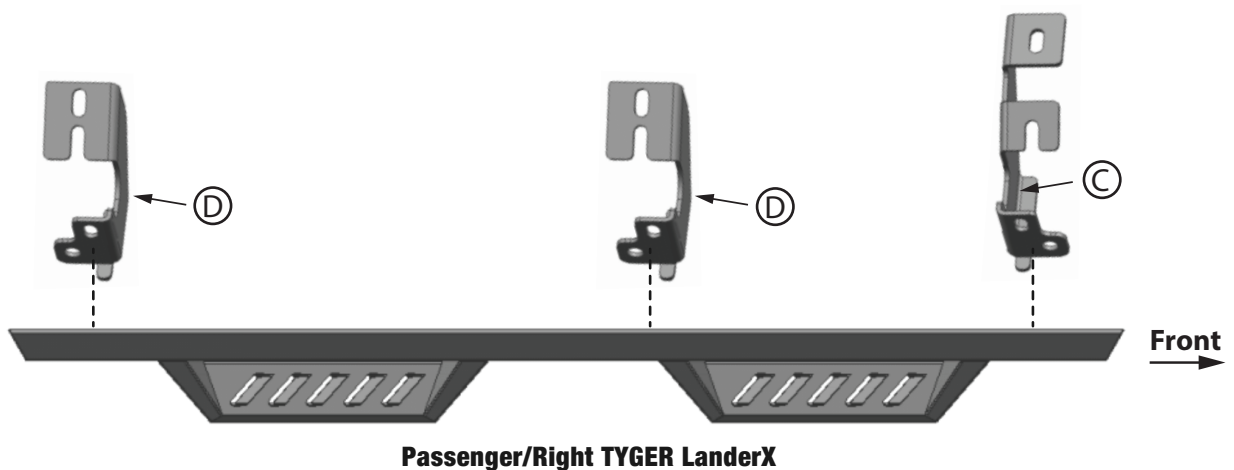
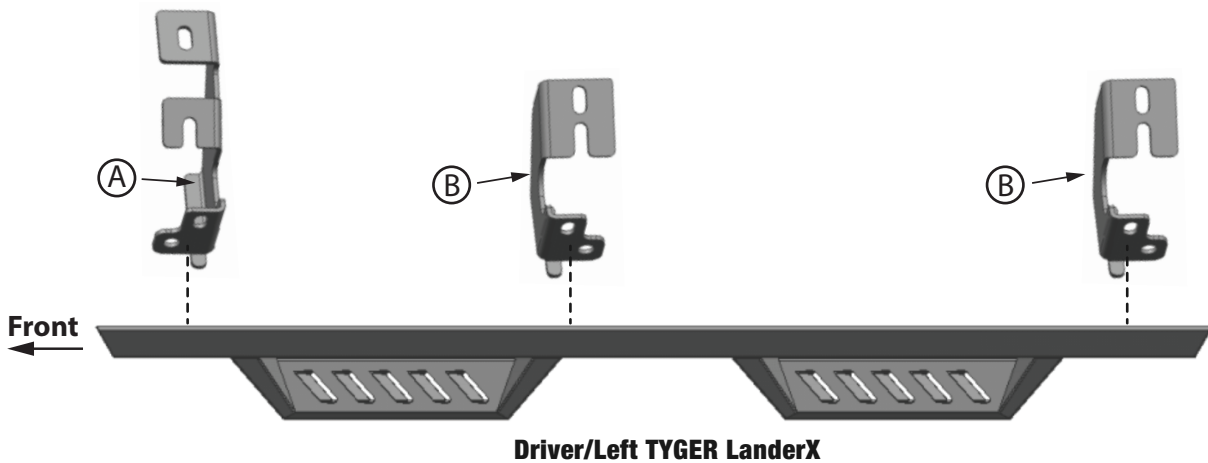

Bottom View

ATTENTION: Refer to the D or P labelling on the tubes to determine the Driver or Passenger side steps.

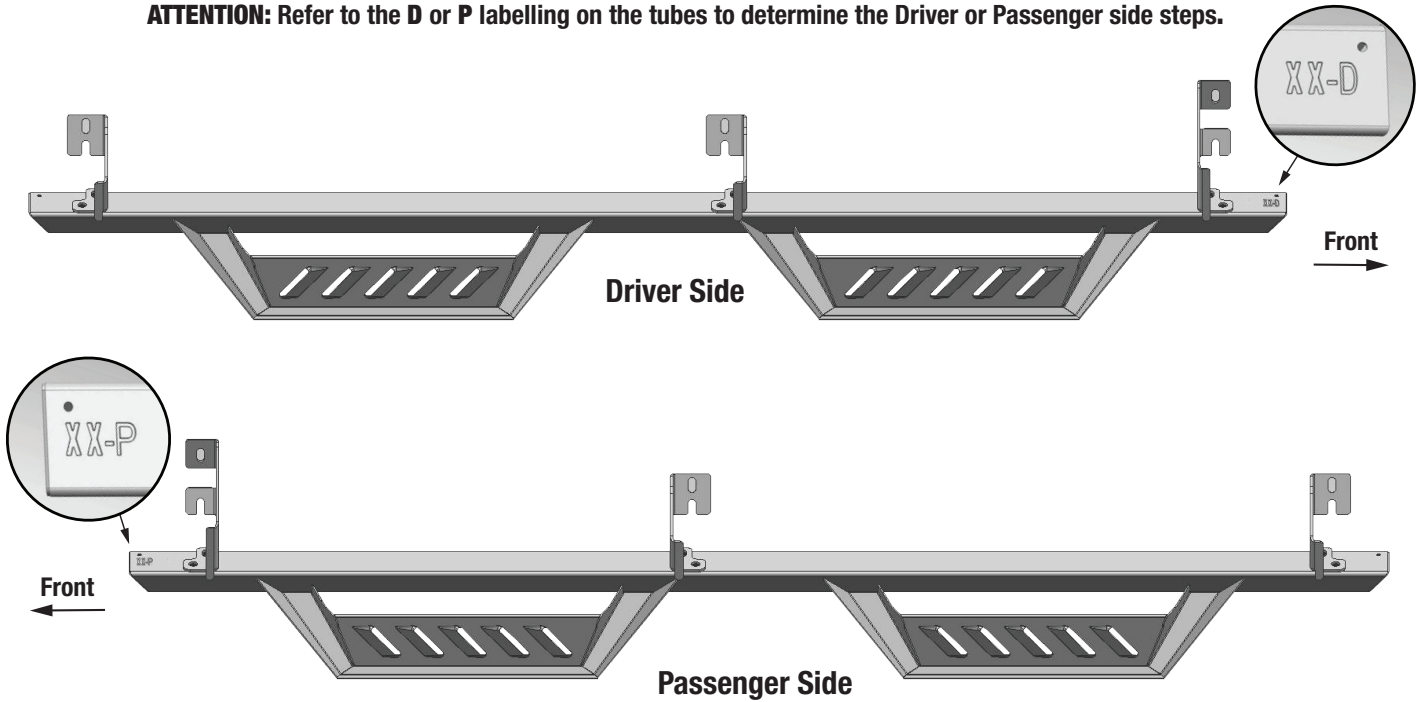

PROCEDURE:

REMOVE CONTENTS FROM BOX. VERIFY ALL PARTS ARE PRESENT. READ INSTRUCTIONS CAREFULLY. ASSISTANCE IS RECOMMENDED.

STEP 1

Starting on the driver/left front of the vehicle, remove the plastic plugs, (or hex bolts), covering the threaded holes in the body panel (Fig 1). Select the Driver/Left Front Mounting Bracket (A). Attach the Bracket to the vehicle with (2) 8mm Hex Bolts, (2) 8mm Lock Washers and (2) 8mm Flat Washers (Fig 2). DO NOT tighten hardware.

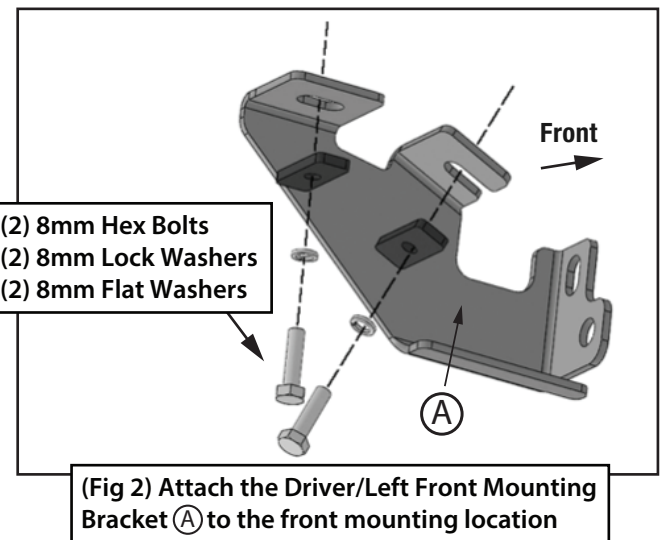
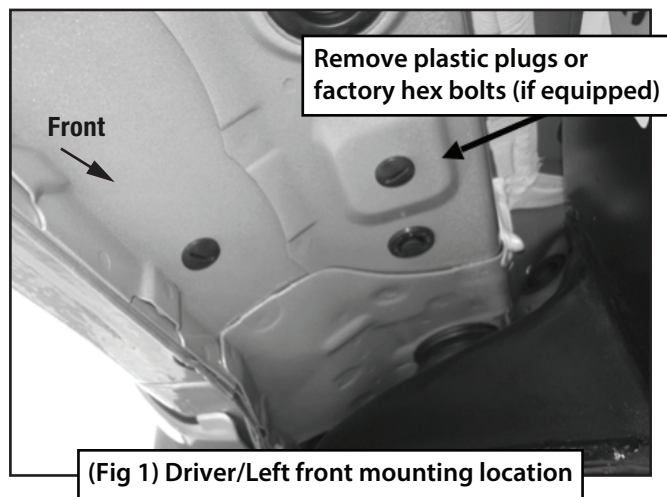

STEP 2

Move along the body panel to the center mounting location. Select (1) Driver/Left Center/Rear Mounting Bracket (B). Repeat **STEP 1** to install the Mounting Bracket (Figs 3 & 4). DO NOT tighten hardware.

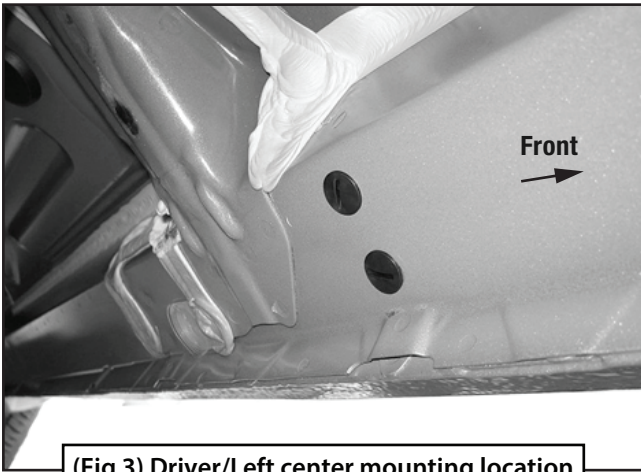

(Fig 3) Driver/Left center mounting location

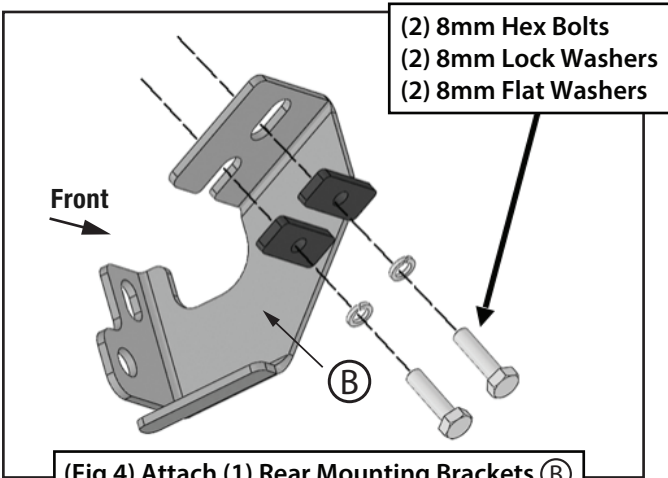

(Fig 4) Attach (1) Rear Mounting Brackets (B) to the center and rear mounting locations

STEP 3

Continue to the last mounting location at the back of the cab (Fig 5). Select (1) Driver/Left Center/Rear Mounting Bracket (B) . Repeat **STEP 1** to attach the Bracket to the rear mounting location. DO NOT tighten hardware.

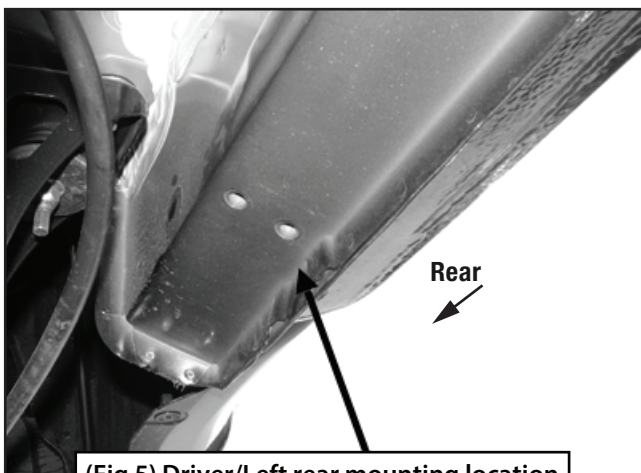

(Fig 5) Driver/Left rear mounting location

STEP 4

Select the Driver/Left TYGER LanderX. Attach the TYGER LanderX to the (3) Mounting Brackets with (6) 8mm Combo Bolts (Fig 6). DO NOT tighten hardware.

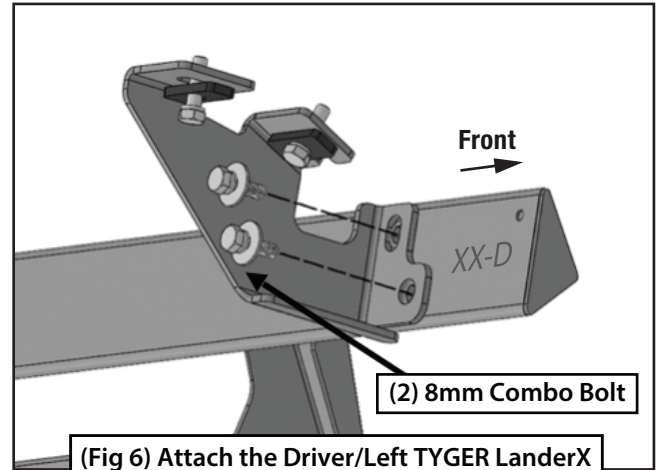

(Fig 6) Attach the Driver/Left TYGER LanderX to the (3) Mounting Brackets

STEP 5

Level and adjust the TYGER LanderX, then tighten all hardware.

STEP 6

Repeat **STEPS 1-5** to attach the Passenger/Right TYGER LanderX.

STEP 7

Do periodic inspections to the installation to make sure that all hardware is secure and tight.