



# TYGER TRAX

TG-NB7D20078

Scan to Download the Latest Digital Version



## BEFORE INSTALLATION

READ INSTRUCTIONS CAREFULLY BEFORE STARTING INSTALLATION. REMOVE CONTENTS FROM BOX AND VERIFY ALL PARTS ARE PRESENT. FAILURE TO IDENTIFY DAMAGE BEFORE INSTALLATION COULD LEAD TO A REJECTION OF ANY CLAIM. IF MISSING PARTS OR ANY DAMAGE FOUND, PLEASE TAKE A PICTURE FOR THE CLAIM PURPOSE. TO FILE YOUR CLAIM, PLEASE VISIT: [WWW.TYGERAUTO.COM/CONTACT](http://WWW.TYGERAUTO.COM/CONTACT)

## TORQUE VALUES

Fastener Size	Class 8.8 Torque (ft-lbs)	Class 10.9 Torque (ft-lbs)
6mm	6-7	6-7
8mm	15-16	22-23
10mm	31-32	44-45
12mm	54-55	78-79
14mm	87-88	125-126

- x1** Driver/Left Tyger Trax
- x1** Passenger/Right Tyger Trax
- x2** Driver Front/Passenger Rear Mounting Brackets (A)
- x2** Passenger Front/Driver Rear Mounting Brackets (C)
- x1** Driver/Left Center Mounting Bracket (B)
- x1** Passenger/Right Center Mounting Brackets (D)
- x6** 8mm Bolt/Nut Plate
- x12** 8mm x 30mm Hex Bolts
- x12** 8mm x 25mm Combo Bolts
- x12** 8mm x 24mm OD x 2mm Flat Washers
- x12** 8mm Lock Washers
- x6** 8mm Hex Nuts
- x6** 8mm Plastic Retainers
- x10** 6mm x 25mm Hex Bolts
- x20** 6mm x 22mm OD x 2mm Flat Washers
- x10** 6mm Nylon Lock Nuts
- x4** 16mm x 60mm Large Spacer
- x2** 16mm x 34mm Small Spacer

## Parts List

Reference the letters printed on the brackets to determine mounting locations

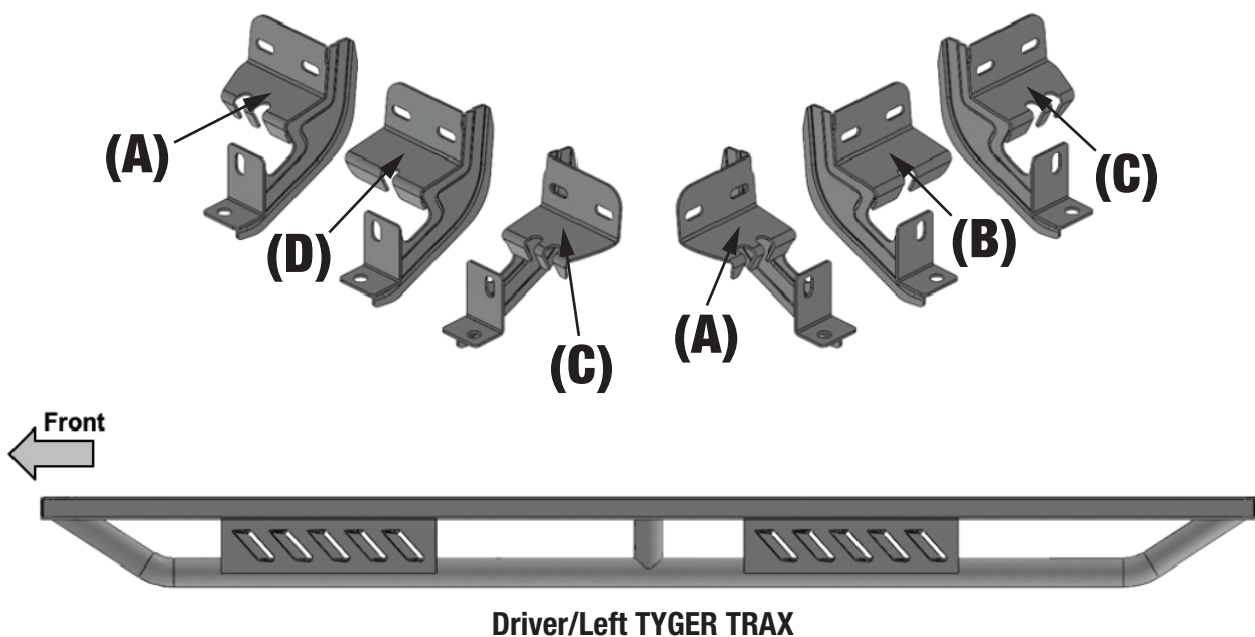

# Bottom View

**ATTENTION:** Refer to the D or P labelling on the tubes to determine the Driver or Passenger side steps.

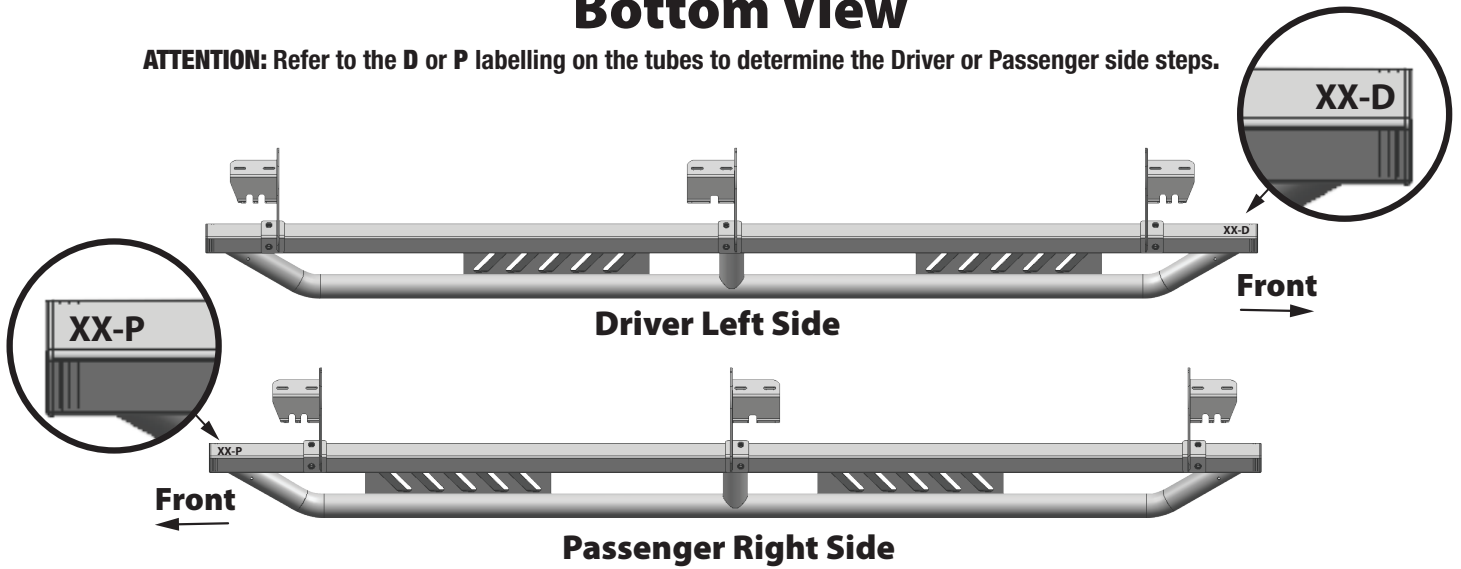

**PROCEDURE:**

REMOVE CONTENTS FROM BOX. VERIFY ALL PARTS ARE PRESENT. READ INSTRUCTIONS CAREFULLY BEFORE STARTING INSTALLATION. DRILLING MAY BE REQUIRED.

**Models without factory threaded inserts in body panel:**

a. Select (1) 8mm Bolt/nut Plate (Fig 2). Partially thread an 8mm Hex Bolt onto the threaded end of the Nut Plate (Fig 3). Thread the Hex Bolt in until it is flush with the welded nut. Use the Hex Bolt as a handle and insert the Bolt and Nut Plate into the oval hole (Fig 4). Feed the threaded bolt on the Bolt Plate through one of the hex shaped factory holes.

## STEP 1

Starting at the driver side-front of the vehicle, remove the sealing tape covering the factory holes in the side of the inner panel (Fig 1).

**Driver/Left Side Installation Pictured**

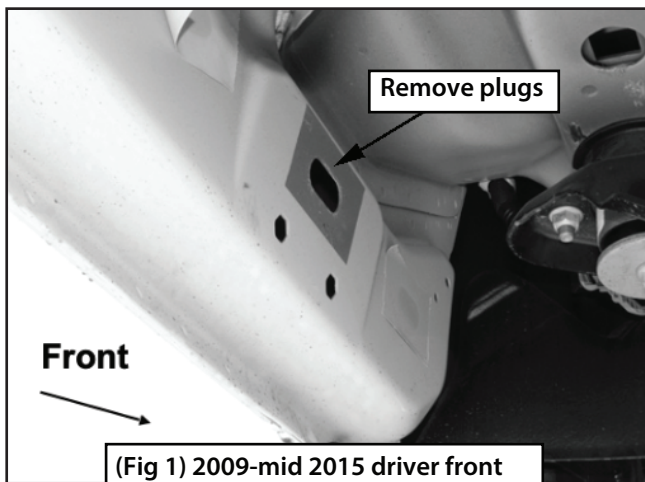

**(Fig 1) 2009-mid 2015 driver front mounting location (No factory holes in pinch weld 2009-2012 models)**

**Driver/Left Side Installation Pictured**

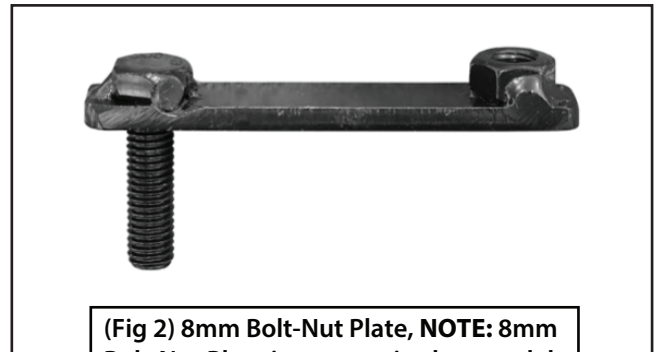

**(Fig 2) 8mm Bolt-Nut Plate, NOTE: 8mm Bolt-Nut Plate is not required on models with threaded inserts**

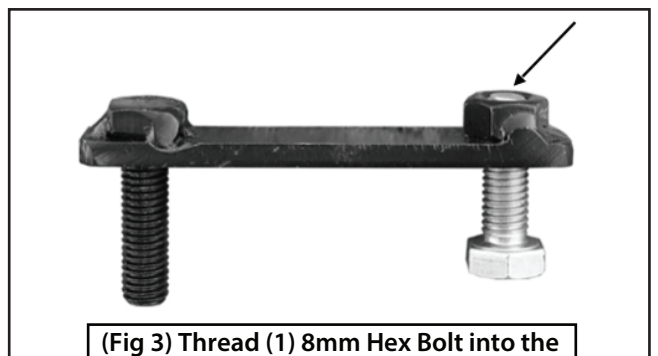

**(Fig 3) Thread (1) 8mm Hex Bolt into the nut on the plate. Stop when bolt reaches end of nut as pictured**

## STEP 2

Determine the correct procedure to attach the driver side front Bracket (A) for your model/year:

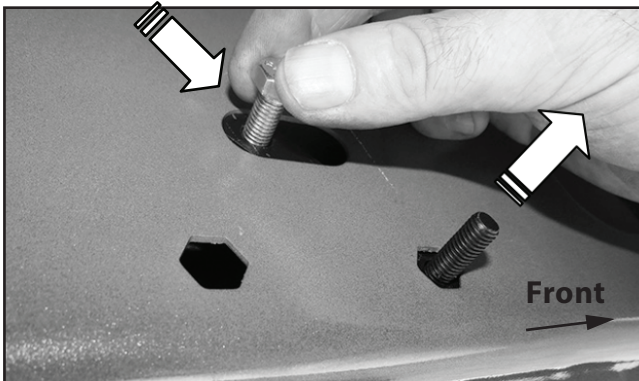

(Fig 4) Use the loose Hex Bolt as a handle. Insert the Bolt Plate into the oval hole and feed the threaded end out either factory hex shaped hole. **IMPORTANT: DO NOT** let go of the hex bolt until after Plastic Retainer has been threaded onto bolt (Fig 5)

b. Thread (1) 8mm Plastic Retainer onto the threaded end and down tight against the body panel (Fig 5). **NOTE:** The Plastic Retainer is designed to keep the Bolt/Nut Plate from falling into the body panel and to aid in Bracket installation.

**Driver/Left Side Installation Pictured**

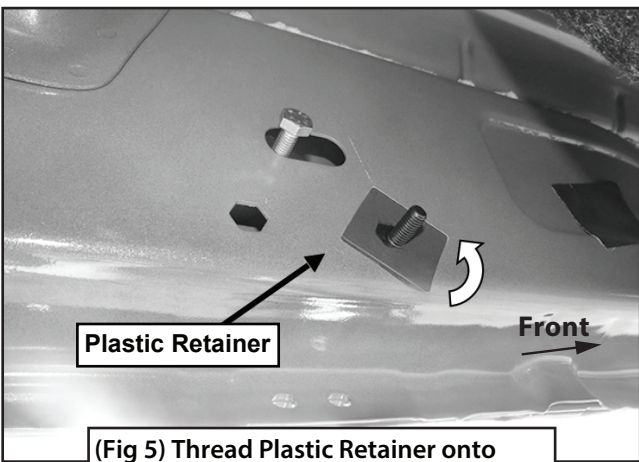

(Fig 5) Thread Plastic Retainer onto Bolt Plate to hold Bolt Plate in position.

c. Select (1) Driver/Left Bracket (A) (Fig 6). Attach the Bracket to the threaded end of the Bolt Plate with (1) 8mm Flat Washer, (1) 8mm Lock washer and (1) 8mm Hex Nut (Fig 6).

**IMPORTANT:** Driver/Left Front Bracket (A) is the same as the Passenger/Right Rear Bracket. **DO NOT** tighten hardware at this time.

**Driver/Left Side Installation Pictured**

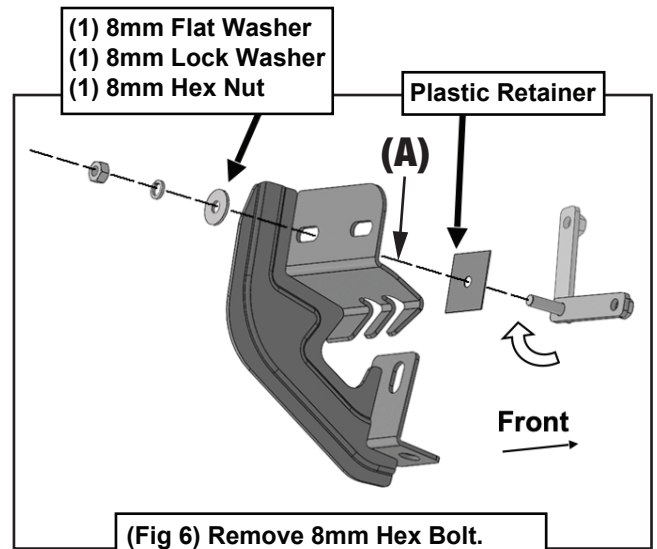

(Fig 6) Remove 8mm Hex Bolt. Rotate Bolt Plate to line up with remaining factory hex shaped hole

d. Remove the 8mm Hex Bolt from the nut on the Bolt Plate from **STEP 2a**. Rotate the Bolt on the Bolt Plate until the threaded nut lines up with the remaining hole in the Mounting Bracket and body panel (Fig 7). Attach the Bracket to the threaded Nut Plate with (1) 8mm x 30mm Hex Bolt, (1) 8mm Lock Washer and (1) 8mm Flat Washer (Fig 7). **DO NOT** tighten hardware.

**Driver/Left Side Installation Pictured**

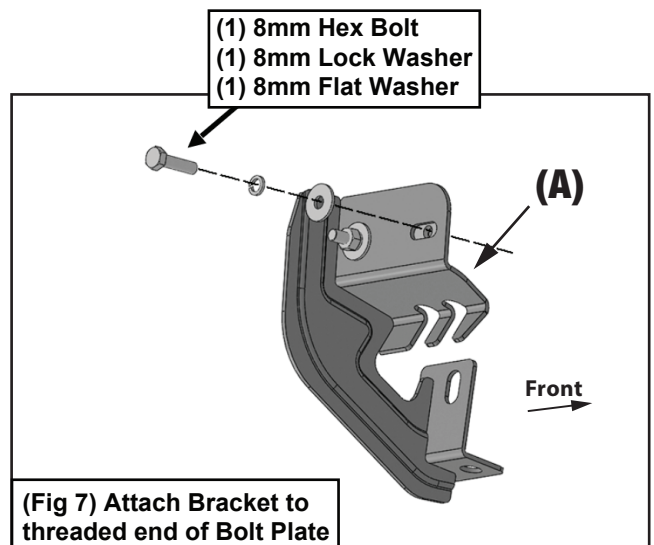

(Fig 7) Attach Bracket to threaded end of Bolt Plate

**Models with factory threaded inserts:**

a. Attach (1) Driver/Left Mounting Bracket to the threaded inserts with (2) 8mm x 30mm Hex Bolts, (2) 8mm Lock Washers and (2) 8mm Flat Washer (Figs 8 & 9). DO NOT tighten hardware.

**IMPORTANT:** Rust or dirt may build up overtime and clog up the holes preventing the bolts to be installed. In this case, use a 8-1.25mm Tap (not included) to clear and cut new threads to allow the bolts to be mounted.

**Driver/Left Side Installation Pictured**

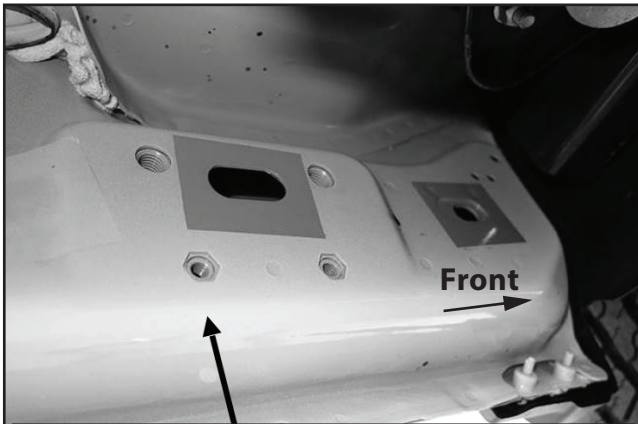

(Fig 8) Driver/left side front mid 2015-on (example of models with factory installed threaded inserts)

(2) 8mm Hex Bolts  
(2) 8mm Lock Washers  
(2) 8mm Flat Washers

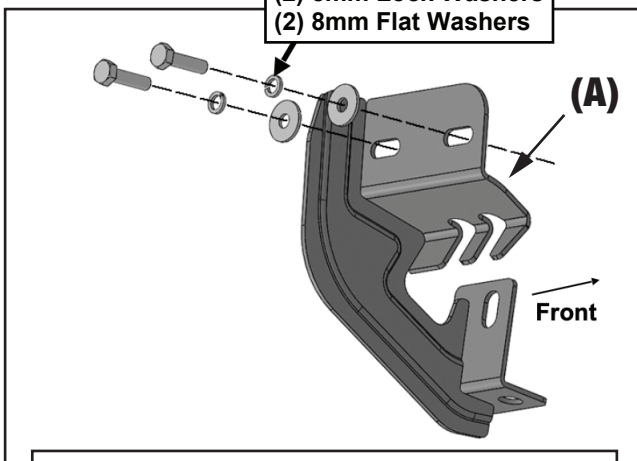

(Fig 9) Driver/left side front models with factory installed threaded inserts. Bolt Plate not required

**STEP 3**

Attach the Bracket to the back of the pinch weld with (2) 6mm Button Head Bolts, (4) 6mm Flat Washers, (1) Large Spacer and (2) 6mm Nylon Lock Nuts (Fig 10). DO NOT fully tighten hardware.

**IMPORTANT:** 2009-12 models not equipped with factory holes will require drilling through the pinch weld to fully attach Bracket. DO NOT drill through pinch weld at this time, (see **STEP 7**).

**Driver/Left Side Installation Pictured**

(2) 6mm Hex Bolts  
(4) 6mm Flat Washers  
(1) Large Spacer  
(2) 6mm Nylon Lock Nuts

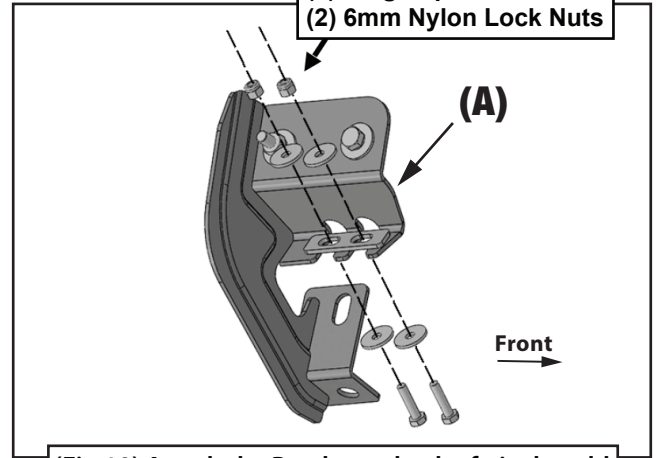

(Fig 10) Attach the Bracket to back of pinch weld (models with factory holes in pinch weld only)

**STEP 4**

Move along the side of the body panel to the center mounting location (Fig 11). Repeat **STEPS 1-3** to install (1) Driver/Left Center Mounting Bracket (B) to the center mounting location. Use (1) Small Spacer instead of Large Spacer for **STEP 3**.

**Driver/Left Side Installation Pictured**

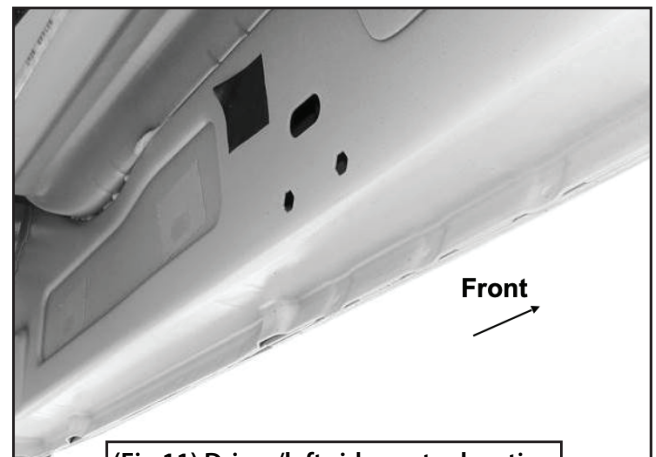

(Fig 11) Driver/left side center location

**STEP 5**

Move to the rear location (Fig 12). Repeat **STEPS 1-3** to attach (1) Passenger/Right Rear Mounting Bracket (C) to the Driver/Left rear mounting location.

**Driver/Left Side Installation Pictured**



(Fig 12) Driver/left rear mounting location

## STEP 6

Select the Driver/Left TYGER TRAX. Place the TYGER TRAX onto the Mounting Brackets and attach with (6) 8mm Combo Bolts (Fig 13). DO NOT tighten hardware.

### Driver/Left Side Installation Pictured

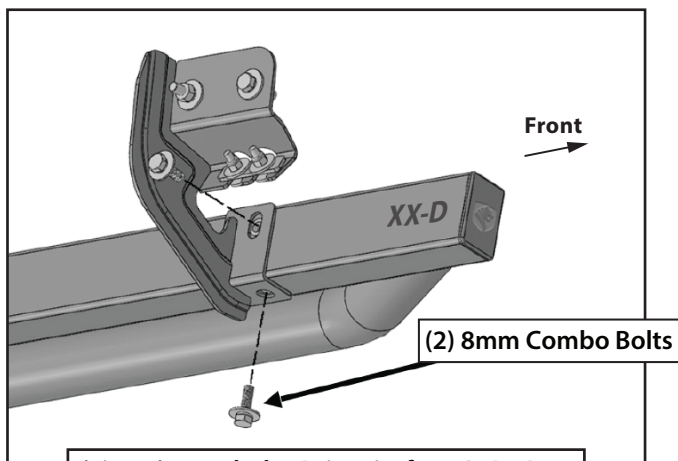

(Fig 13) Attach the Driver/Left TYGER TRAX to the (3) Mounting Brackets

## STEP 7

Repeat **STEPS 1-6** to attach the Passenger/Right TYGER TRAX.

Properly level and adjust the TYGER TRAX and fully tighten all hardware.

### 2009-12 models requiring drilling through pinch trim:

- a. Level the TYGER TRAX to the vehicle. Make sure all (3) Brackets are tight against the bottom of the body panel and tighten all mounting hardware.
- b. Mark the location of the slots onto the pinch weld.
- c. Drill (2) 1/4" holes through the pinch weld for each Bracket. **IMPORTANT:** DO NOT drill too close to the bottom edge of the pinch weld. Drill the holes in the center of the marked slots.
- d. Repeat **STEP 3** to attach the Brackets to the drilled holes in the pinch weld. Check for level then fully tighten all hardware.

## STEP 8

Repeat **STEPS 1-7** to attach the Passenger/Right TYGER TRAX.

## STEP 9

Do periodic inspections to the installation to make sure that all hardware is secure and tight.