



TYGER TRAX

TG-NB7T20208

BEFORE INSTALLATION

READ INSTRUCTIONS CAREFULLY BEFORE STARTING INSTALLATION. REMOVE CONTENTS FROM BOX AND VERIFY ALL PARTS ARE PRESENT. FAILURE TO IDENTIFY DAMAGE BEFORE INSTALLATION COULD LEAD TO A REJECTION OF ANY CLAIM. IF MISSING PARTS OR ANY DAMAGE FOUND, PLEASE TAKE A PICTURE FOR THE CLAIM PURPOSE. TO FILE YOUR CLAIM, PLEASE VISIT: WWW.TYGERAUTO.COM/CONTACT

TORQUE VALUES

Fastener Size	Class 8.8 Torque (ft-lbs)	Class 10.9 Torque (ft-lbs)
6mm	6-7	6-7
8mm	15-16	22-23
10mm	31-32	44-45
12mm	54-55	78-79
14mm	87-88	125-126

- x1** Driver/Left Tyger Trax
- x1** Passenger/Right Tyger Trax
- x1** Driver/Left Front Mounting Bracket (A)
- x1** Passenger/Right Front Mounting Bracket (D)
- x1** Driver/Left Second Mounting Bracket (B)
- x1** Passenger/Right Second Mounting Bracket (E)
- x2** Driver/Left Rear Mounting Brackets (C)
- x2** Passenger/Right Rear Mounting Brackets (F)
- x16** 8mm x 30mm Hex Bolts
- x16** 8mm x 25mm Combo Bolts
- x16** 8mm Lock Washers
- x16** 8mm x 24mm OD x 2mm Flat Washers

Parts List

Reference the letters printed on the brackets to determine mounting locations

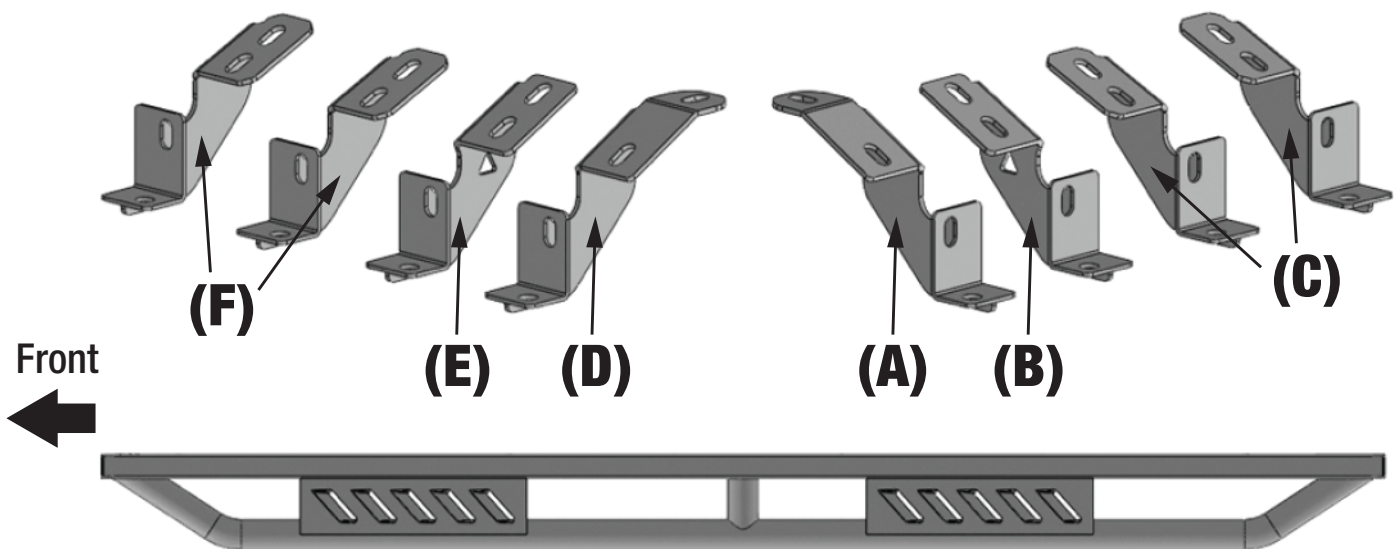

Driver/Left TYGER TRAX

Bottom View

ATTENTION: Refer to the **D** or **P** labelling on the tubes to determine the Driver or Passenger side steps.

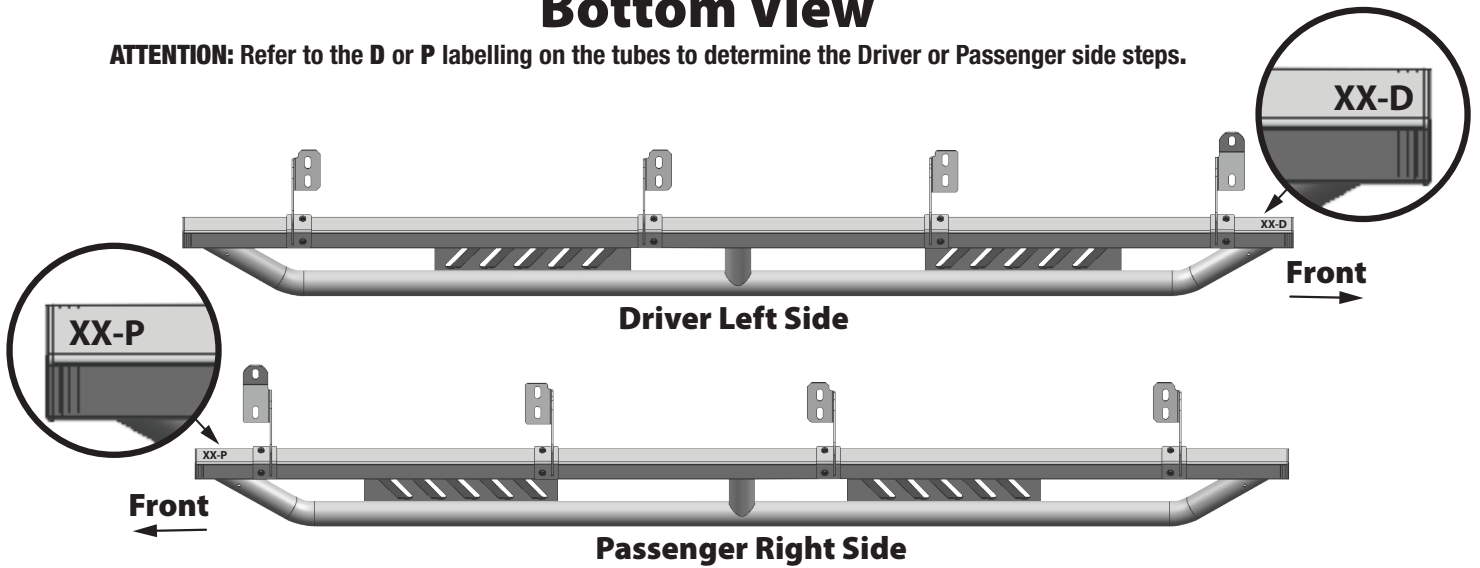

PROCEDURE:

REMOVE CONTENTS FROM BOX. VERIFY ALL PARTS ARE PRESENT.
 READ INSTRUCTIONS CAREFULLY. ASSISTANCE IS HIGHLY RECOMMENDED.

STEP 1

Starting on the driver/left side of the vehicle and remove the plastic plugs or hex bolts from the factory mounting location along the bottom of the body (Figs 1 & 2).

Driver/Left Side Installation Pictured

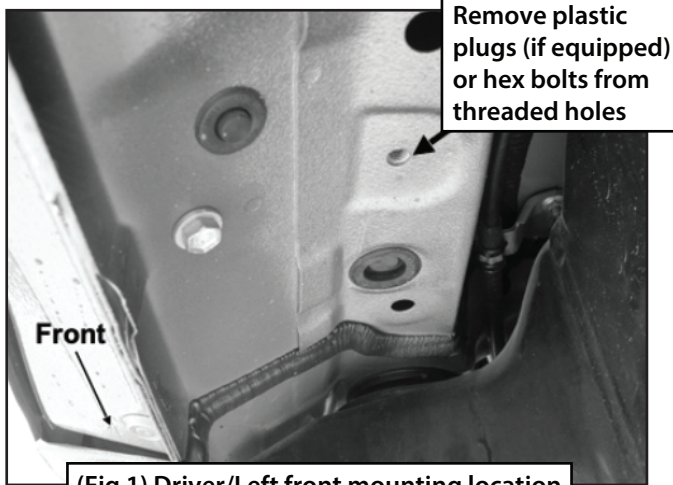

(Fig 1) Driver/Left front mounting location

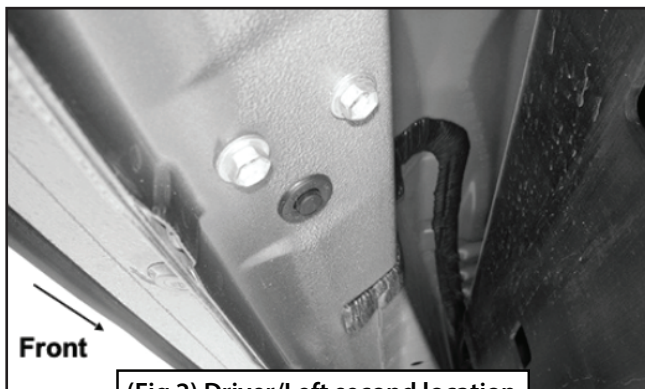

(Fig 2) Driver/Left second location

STEP 2

Select the Driver/Left Front Mounting Bracket (A). Attach the Bracket to the front location with (2) 8mm Hex Bolts, (2) 8mm Lock Washers and (2) 8mm Flat Washers (Fig 3). DO NOT tighten hardware.

Driver/Left Side Installation Pictured

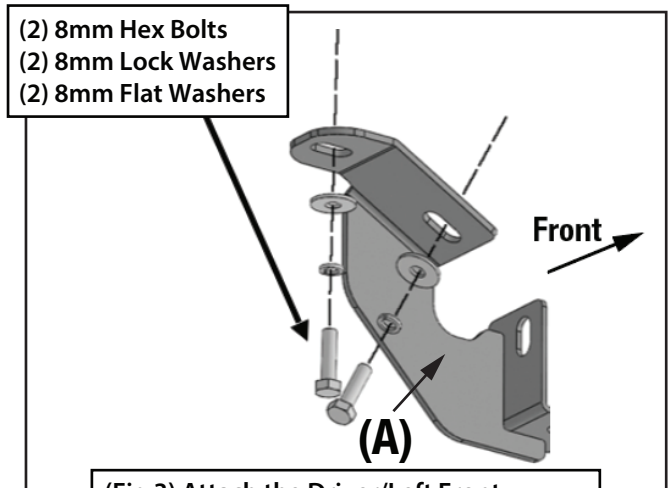

(Fig 3) Attach the Driver/Left Front Mounting Bracket (A) to the front location

STEP 3

For the Second (B) and Rear Mounting Brackets (C) refer to (Fig 4) to determine the correct Mounting Bracket.

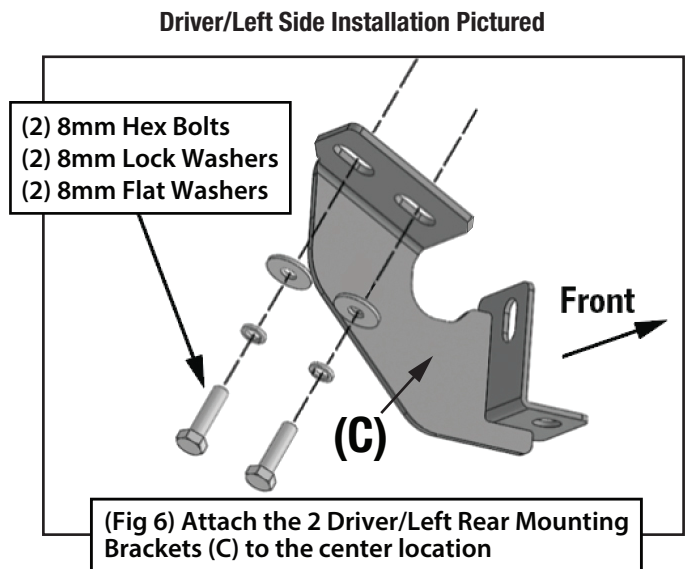
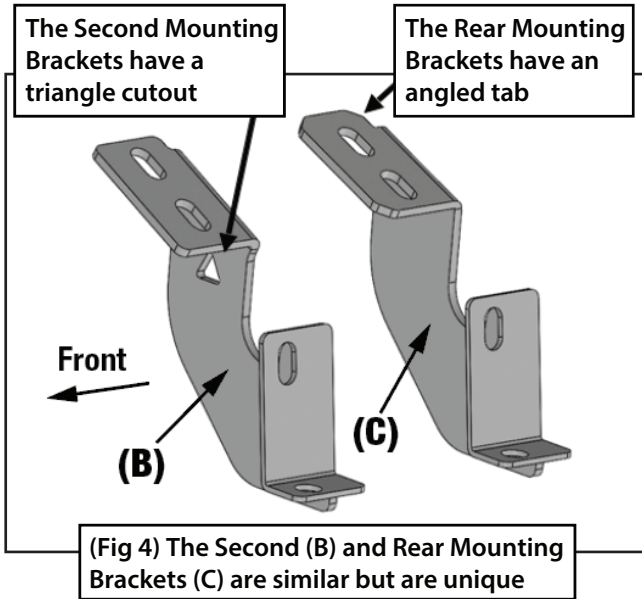

STEP 6

Select the Driver/Left TYGER TRAX. Attach the TYGER TRAX to the Mounting Brackets with (6) 8mm Combo Bolts (Fig 7). DO NOT tighten hardware.

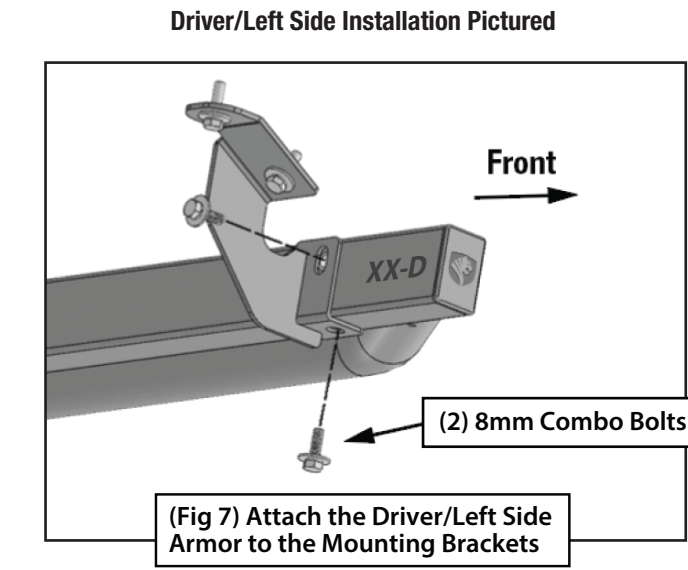

STEP 7

Level and adjust the TYGER TRAX and tighten all hardware.

STEP 8

Repeat **STEPS 1-7** to attach the Passenger/Right TYGER TRAX.

STEP 9

Do periodic inspections to the installation to make sure that all hardware is secure and tight.

STEP 4

Repeat **STEPS 1 & 2** to attach (1) Driver/Left Second Mounting Bracket (B) to the second location (Fig 5).

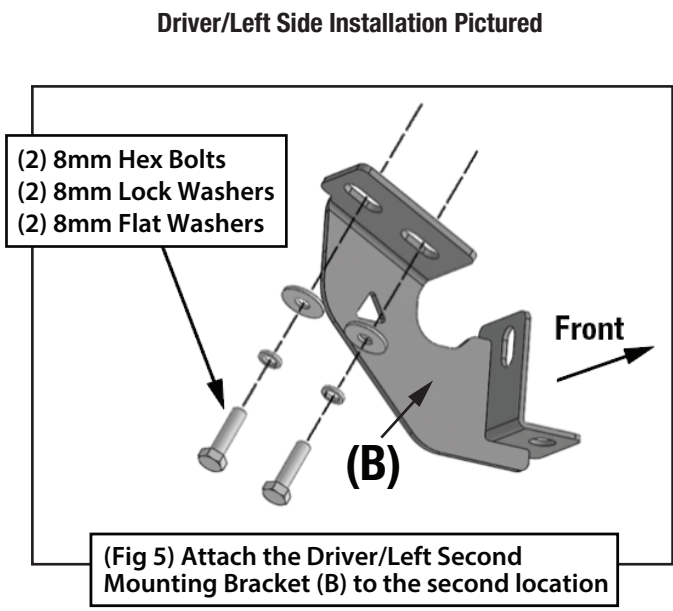

STEP 5

Repeat **STEPS 1 & 2** to attach (2) Rear Mounting Brackets (C) to the rear locations (Fig 6).