



RISER®

TG-RS6C60028

Scan to Download the Latest Digital Version



BEFORE INSTALLATION

READ INSTRUCTIONS CAREFULLY BEFORE STARTING INSTALLATION. REMOVE CONTENTS FROM BOX AND VERIFY ALL PARTS ARE PRESENT. FAILURE TO IDENTIFY DAMAGE BEFORE INSTALLATION COULD LEAD TO A REJECTION OF ANY CLAIM. IF MISSING PARTS OR ANY DAMAGE FOUND, PLEASE TAKE A PICTURE FOR THE CLAIM PURPOSE. TO FILE YOUR CLAIM, PLEASE VISIT: WWW.TYGERAUTO.COM/CONTACT

TORQUE VALUES

Fastener Size	Class 8.8 Torque (ft-lbs)	Class 10.9 Torque (ft-lbs)
6mm	6-7	6-7
8mm	15-16	22-23
10mm	31-32	44-45
12mm	54-55	78-79
14mm	87-88	125-126

- x1** Driver Side Riser **D**
- x1** Passenger Side Riser **P**
- x5** Brackets **[A]**
- x1** Passenger Side Front Bracket **[B]**
- x1** Passenger Side Front Support Bracket **[D]**
- x1** Bolt Plate
- x12** 8mm Combo Bolts
- x11** 8mm Clip Nuts
- x13** 8-1.25mm x 25mm Hex Bolts
- x1** 8mm Nylon Lock Nut
- x13** 8mm x 24mm x 2mm Flat Washers
- x13** 8mm Lock Washers

[Parts List](#)

Top View

ATTENTION: Refer to **D** and **P** labelling on the side of the tubes to determine Driver and Passenger Riser

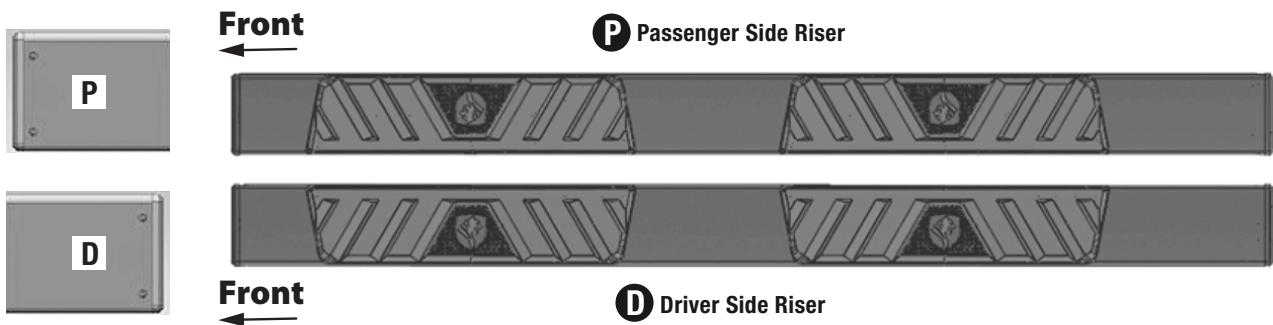

[A]
Brackets

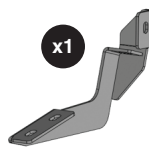

[B]
Passenger Side
Front Bracket

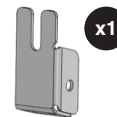

[D]
Passenger Side
Front Support Bracket



Bolt Plate

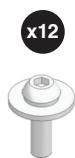

Combo Bolts



Hex Bolts



Flat Washers



Nylon Lock Nut



Lock Washers



Clip Nuts

Reference the letters printed on the brackets to determine mounting locations

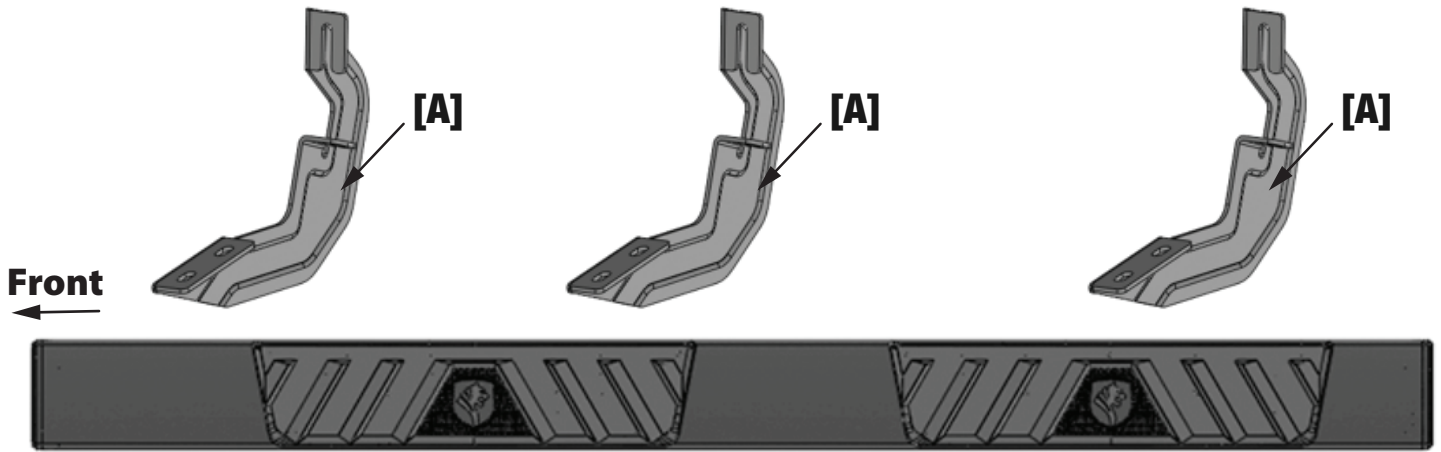

D Driver Side Riser

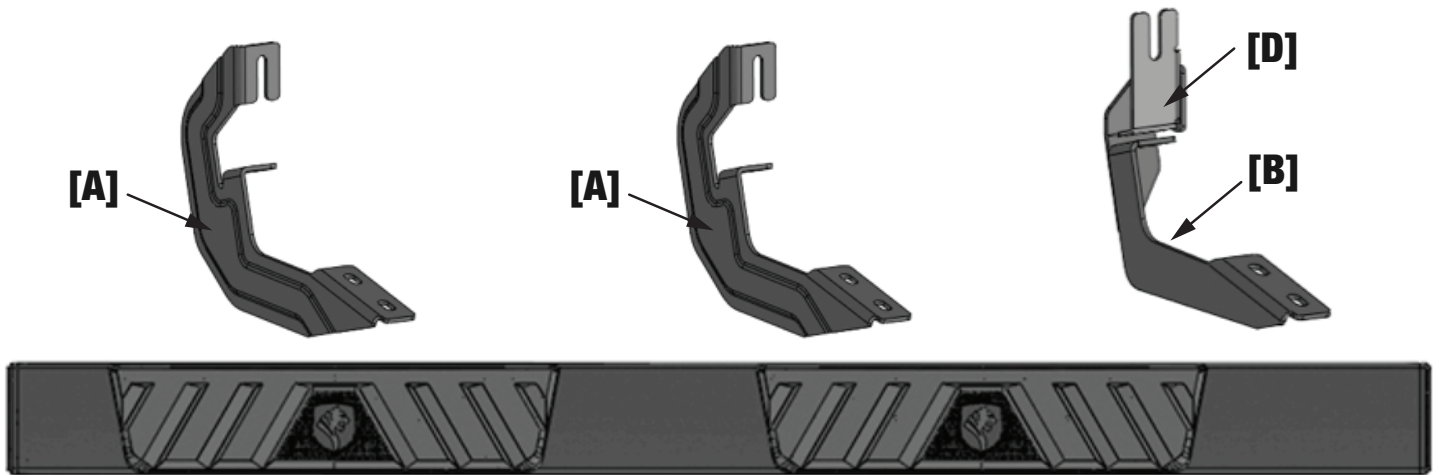

P Passenger Side Riser

Bottom View

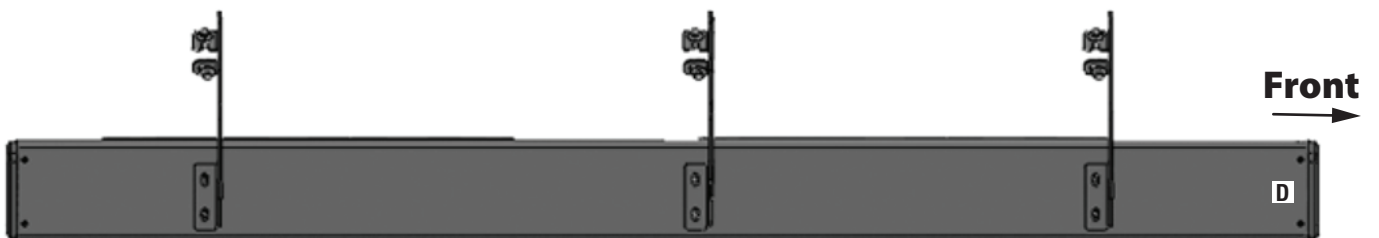

D Driver Side Riser

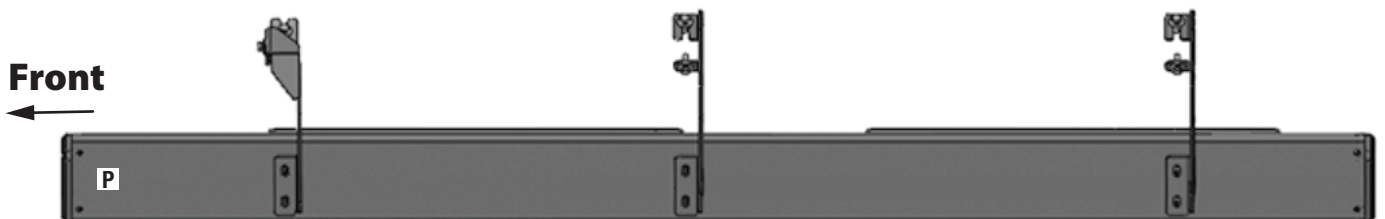

P Passenger Side Riser

TOOLS REQUIRED

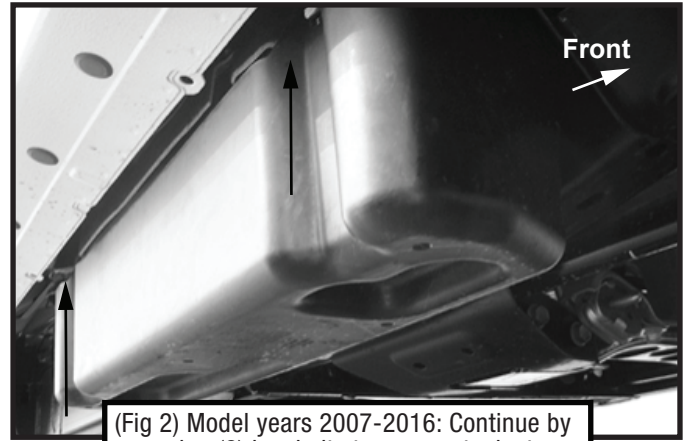
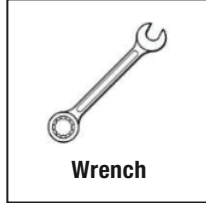
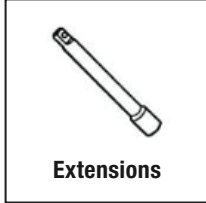
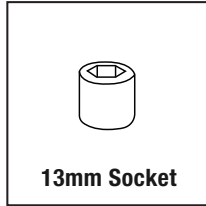
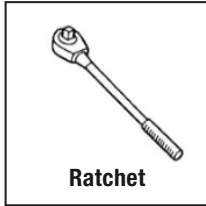

(Fig 2) Model years 2007-2016: Continue by removing (2) hex bolts to remove tank straps



(Fig 3) Model years 2017-onward: Remove (4) hex bolts to remove plastic DEF cover

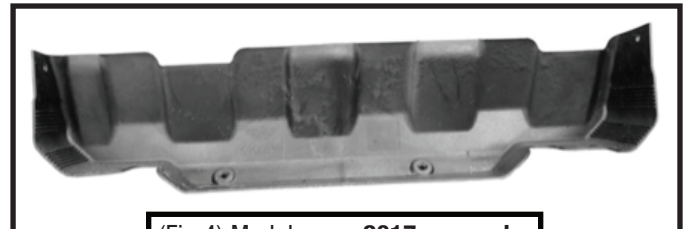

(Fig 4) Model years 2017-onward: Removed Passenger Side DEF cover

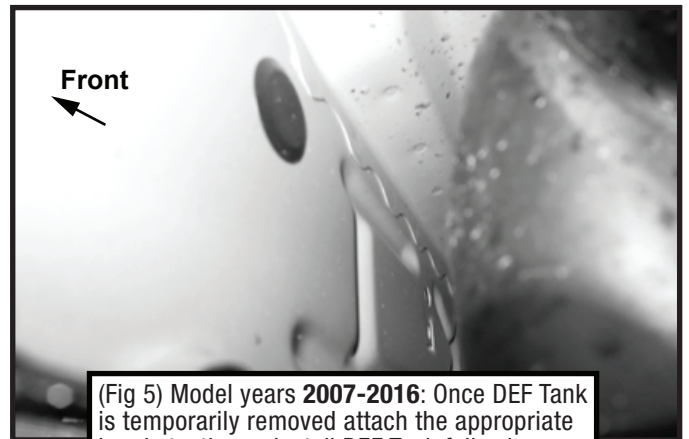

(Fig 5) Model years 2007-2016: Once DEF Tank is temporarily removed attach the appropriate brackets, then reinstall DEF Tank following (Fig 6-onward)

STEP 1 MOUNTING BRACKETS

Follow (Fig 1 – 22) to attach the brackets to the Passenger Side with a DEF Tank.

Note: 2007-2016 will be different from 2017-onward
Skip to (Fig 6) if your vehicle does not have a DEF Tank

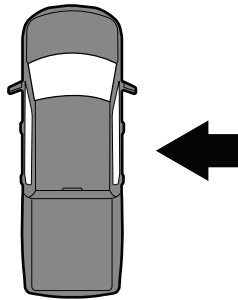

Passenger-side Front Mounting Area

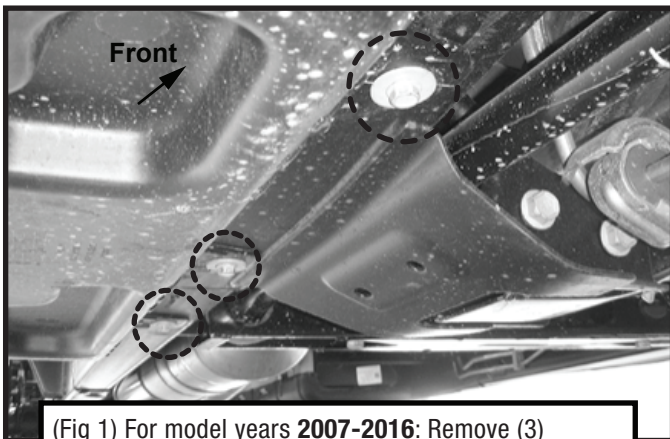

(Fig 1) For model years 2007-2016: Remove (3) hex bolts underneath vehicle to remove DEF tank cover

Verify which type of rocker panel configuration your vehicle has to see if **CLIP NUTS** are necessary (Fig 6-8).

	UPPER PANEL	PINCH WELD
Config 1 (Fig 6)	with threaded insert	with welded nuts
Config 2 (Fig 7)	with threaded insert	flat tab with hole
Config 3 (Fig 8)	no threaded insert	flat tab with hole

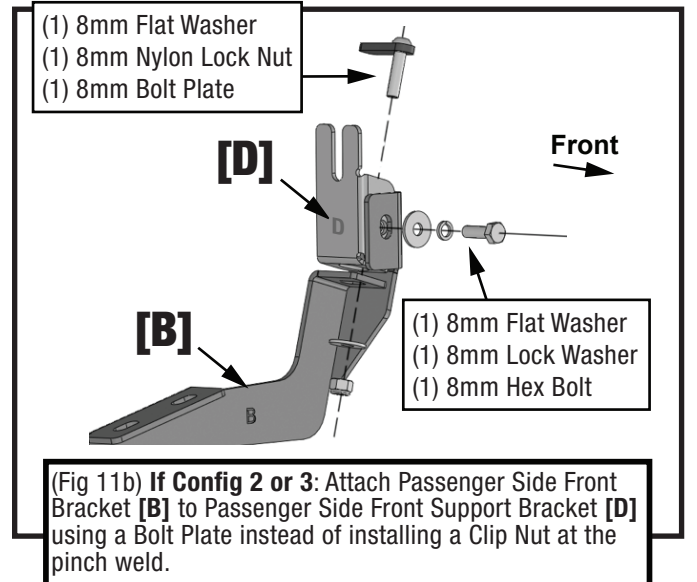
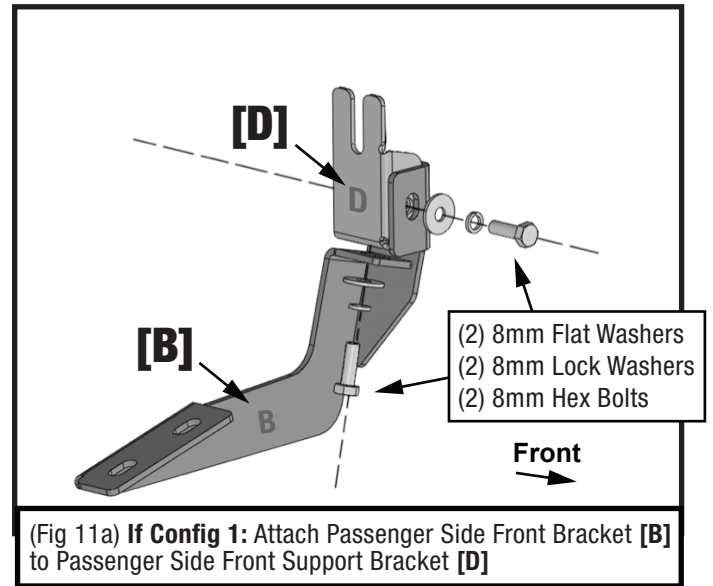
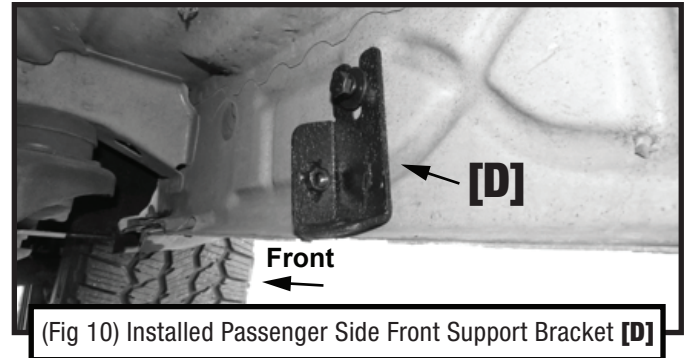
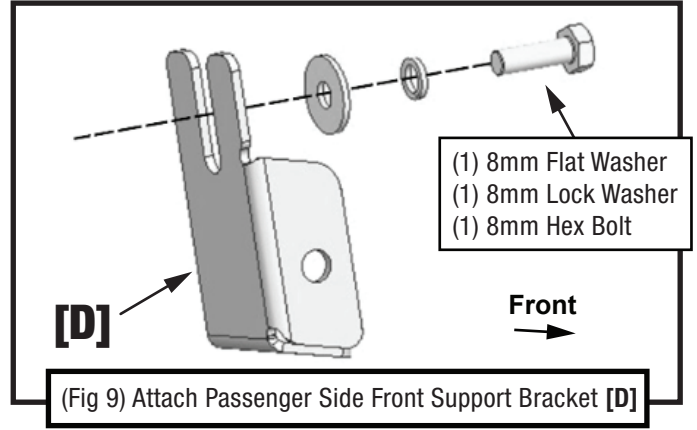
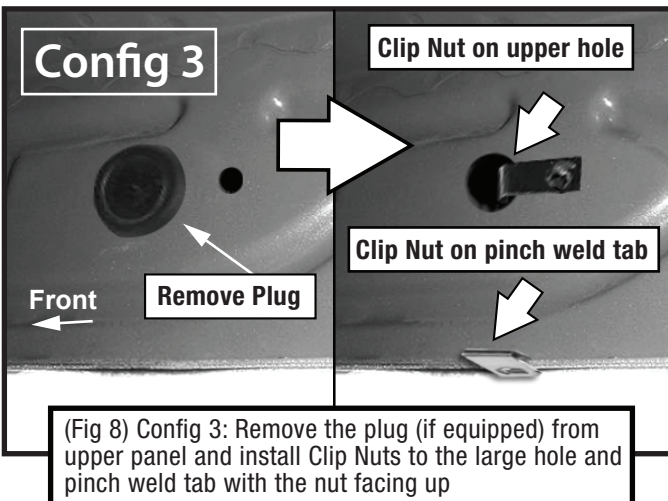
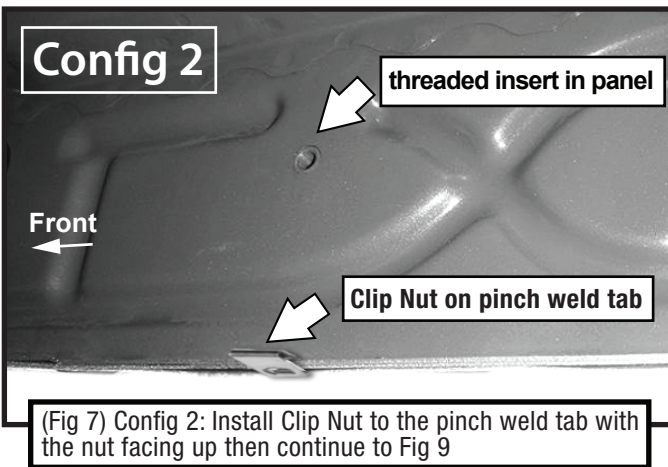
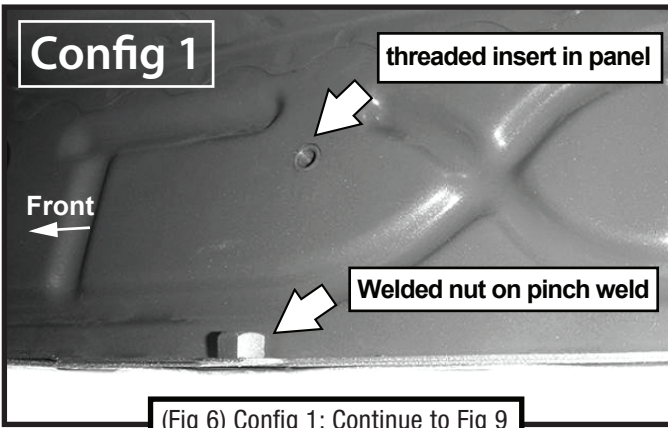

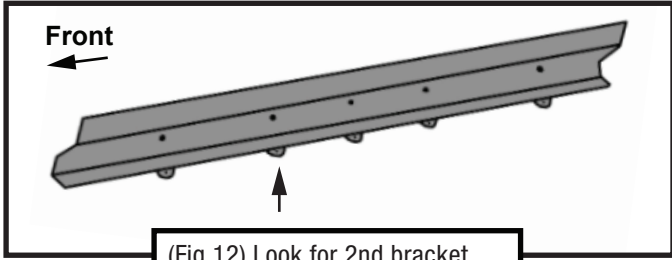

(Fig 12) Look for 2nd bracket location from back of body panel

Note: After (Fig 13) skip to (Fig 15) if your vehicle is not (2017 – on), continue to install bracket at center mounting location

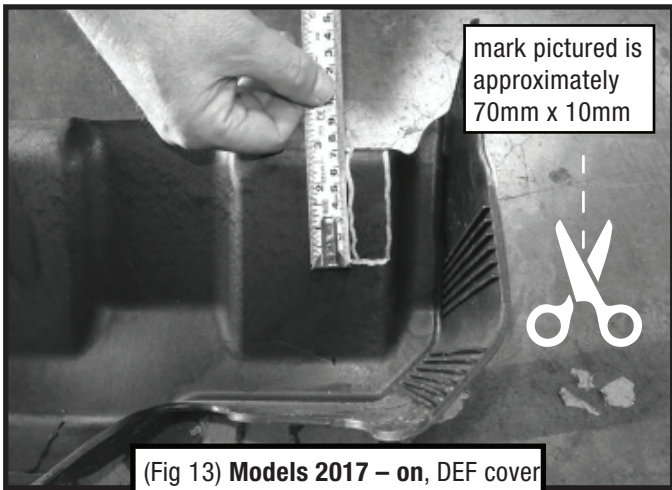

(Fig 13) Models 2017 – on, DEF cover marked for trimming

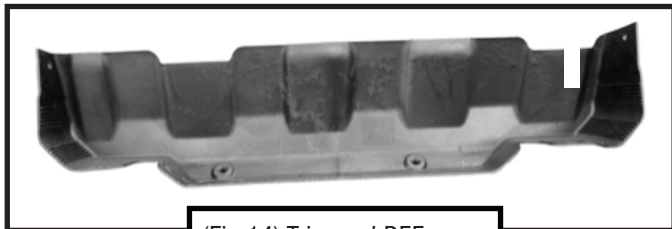

(Fig 14) Trimmed DEF cover

Passenger-side Center Mounting Area

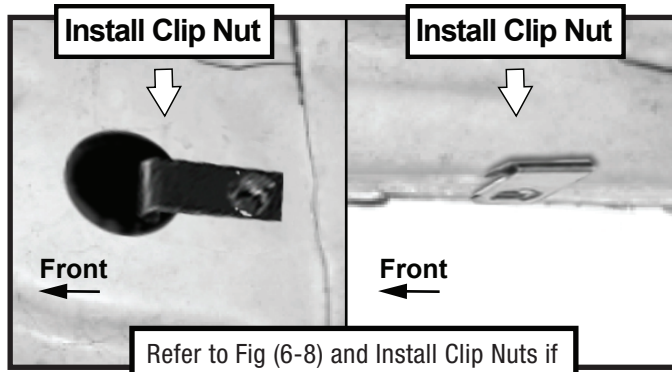

Refer to Fig (6-8) and Install Clip Nuts if needed for **center** mounting location

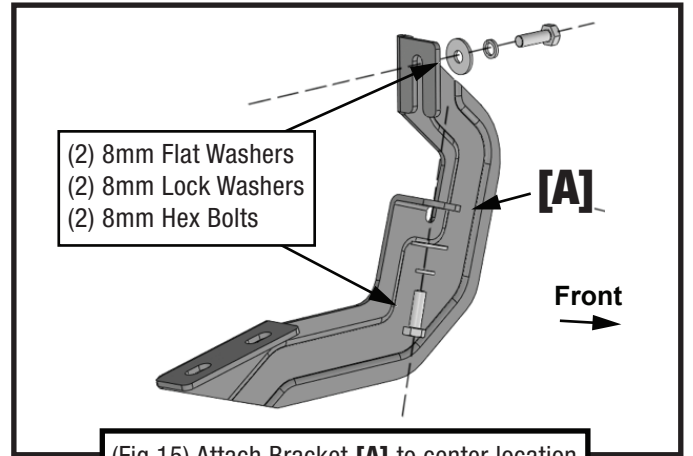

(Fig 15) Attach Bracket [A] to center location

Passenger-side Rear Mounting Area

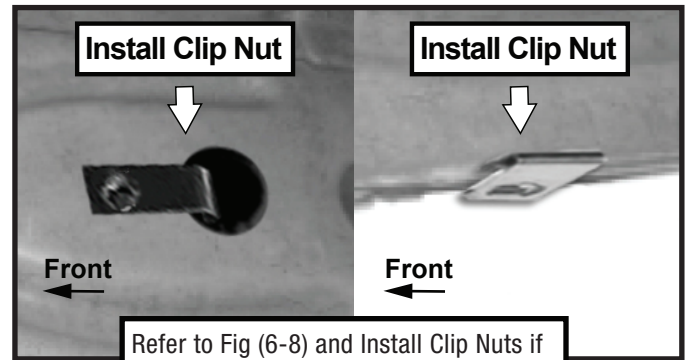

Refer to Fig (6-8) and Install Clip Nuts if needed for **rear** mounting location

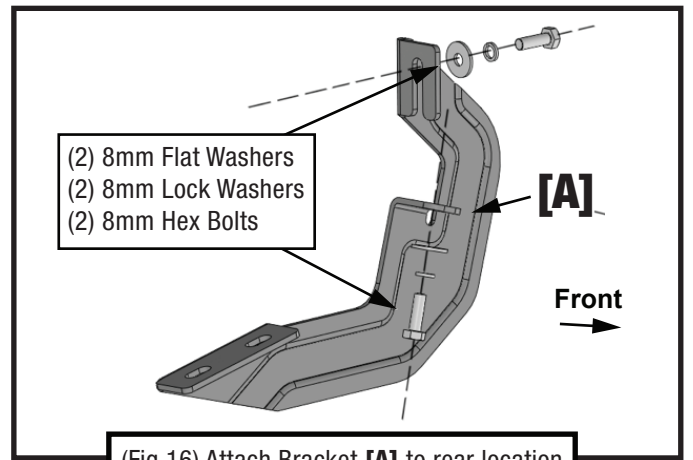

(Fig 16) Attach Bracket [A] to rear location

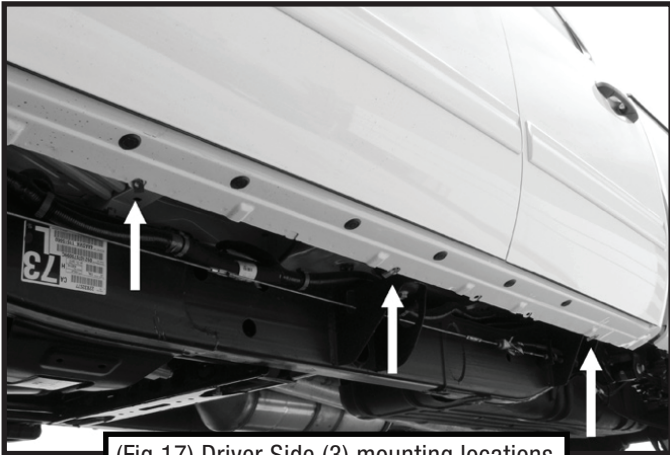
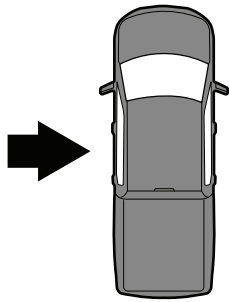

(Fig 17) Driver Side (3) mounting locations

Driver-side Front Mounting Area

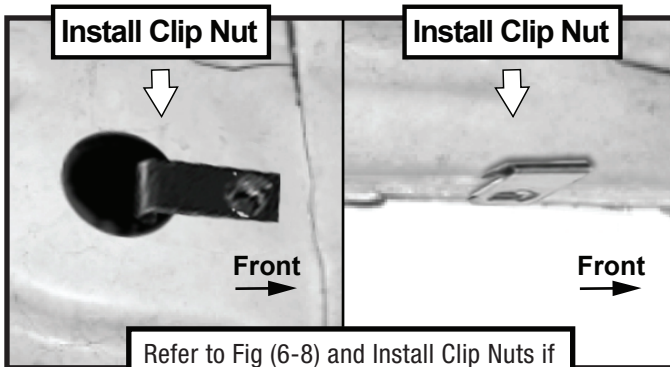

Refer to Fig (6-8) and Install Clip Nuts if needed for **center** mounting location

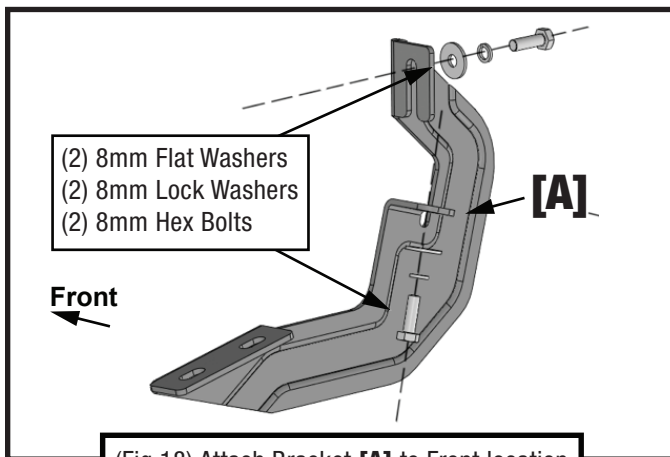

(Fig 18) Attach Bracket [A] to Front location

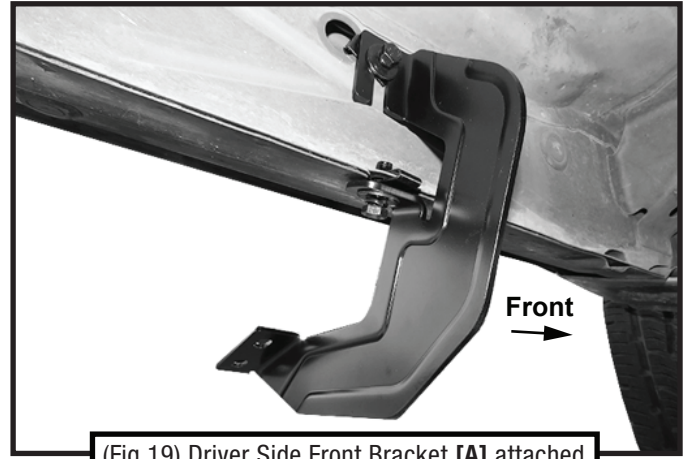

(Fig 19) Driver Side Front Bracket [A] attached

Driver-side Center Mounting Area

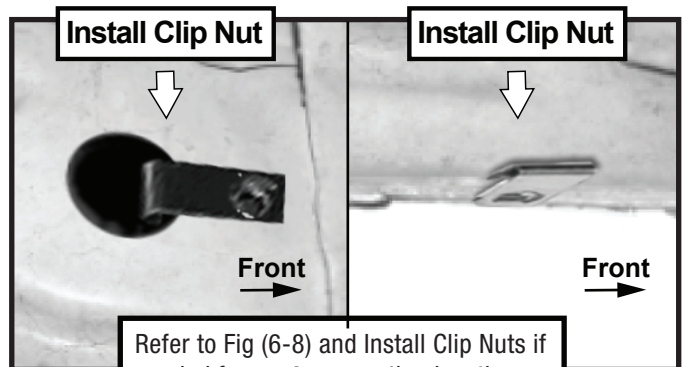

Refer to Fig (6-8) and Install Clip Nuts if needed for **center** mounting location

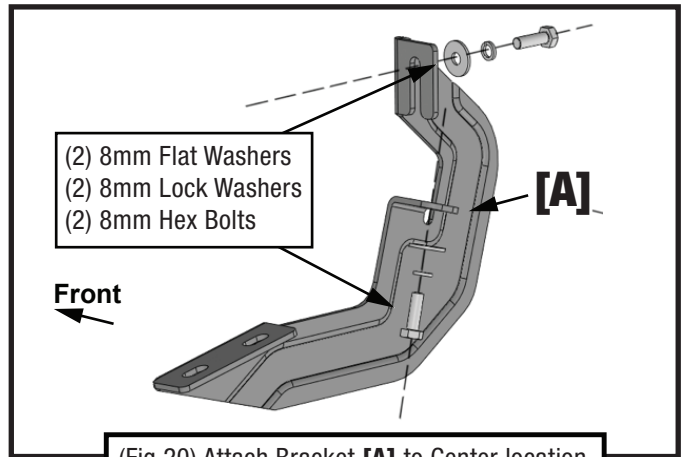

(Fig 20) Attach Bracket [A] to Center location



(Fig 21) Driver Side Center Bracket [A] attached

Driver-side Rear Mounting Area

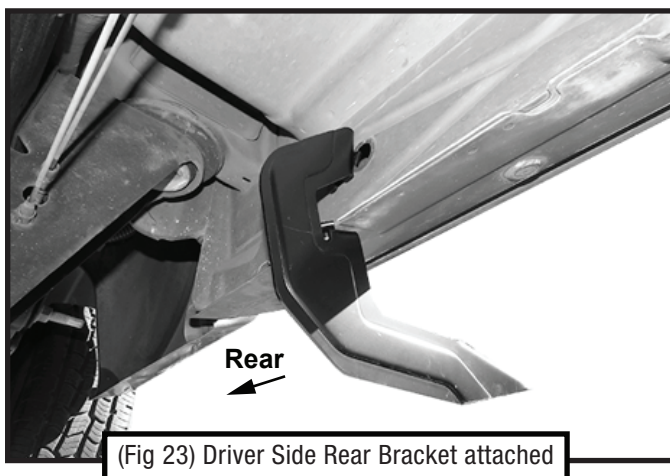
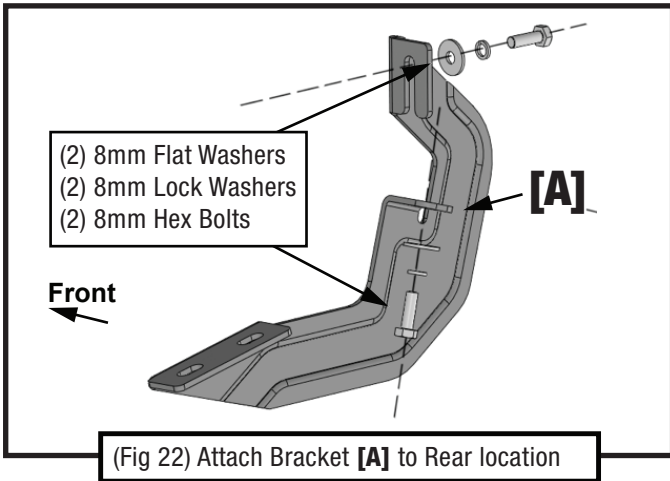
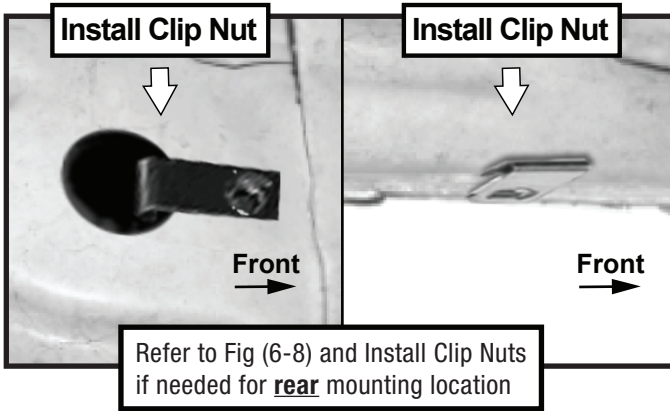

STEP 2 MOUNTING RUNNING BOARDS

Follow (Fig 24) to install the running board on each bracket for both sides.

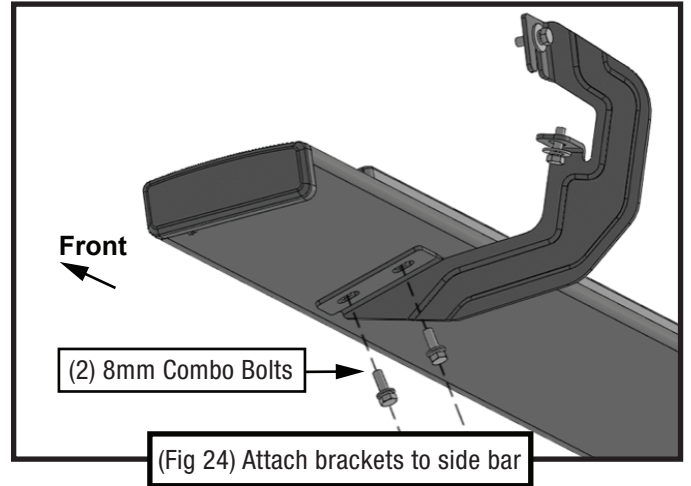

STEP 3

Installation is complete. Do periodic inspections to the installation to make sure that all hardware is secure and tight.

