



RISER®

TG-RS6D60268

BEFORE INSTALLATION

READ INSTRUCTIONS CAREFULLY BEFORE STARTING INSTALLATION. REMOVE CONTENTS FROM BOX AND VERIFY ALL PARTS ARE PRESENT. FAILURE TO IDENTIFY DAMAGE BEFORE INSTALLATION COULD LEAD TO A REJECTION OF ANY CLAIM. IF MISSING PARTS OR ANY DAMAGE FOUND, PLEASE TAKE A PICTURE FOR THE CLAIM PURPOSE. TO FILE YOUR CLAIM, PLEASE VISIT: WWW.TYGERAUTO.COM/CONTACT

TORQUE VALUES

| Fastener Size | Class 8.8 Torque (ft-lbs) | Class 10.9 Torque (ft-lbs) |
|---------------|---------------------------|----------------------------|
| 6mm | 6-7 | 6-7 |
| 8mm | 15-16 | 22-23 |
| 10mm | 31-32 | 44-45 |
| 12mm | 54-55 | 78-79 |
| 14mm | 87-88 | 125-126 |

- x1 Driver/Left 6inch Tyger Riser **[D]**
- x2 Center Mounting Brackets **[C]**
- x4 8-1.25mm x 25mm Hex Bolts
- x1 Passenger/Right 6inch Tyger Riser **[P]**
- x2 Rear Mounting Brackets **[E]**
- x26 8mm Nylon Lock Nuts
- x2 Front Upper Mounting Brackets **[B]**
- x4 Center/Rear Support Brackets **[D]**
- x22 8mm x 24mm x 2mm Flat Washers
- x2 Front Lower Mounting Brackets **[A]**
- x12 8mm x 25mm Combo Bolts
- x8 8mm x 16mm x 1.6mm Flat Washers

Parts List

Top View

ATTENTION: Refer to **[D]** and **[P]** labelling on the side of the tubes to determine Driver and Passenger Tyger Riser

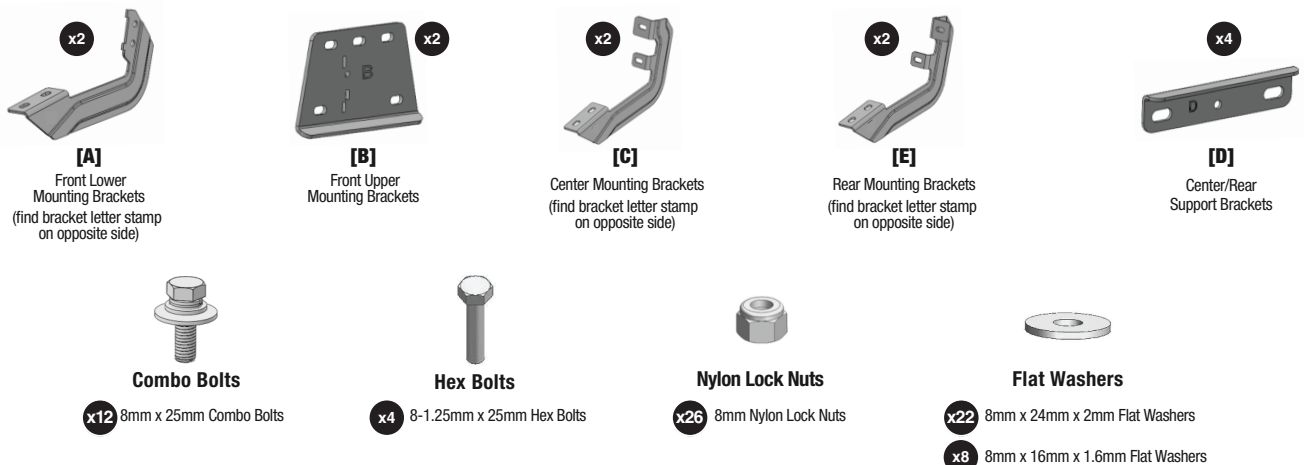
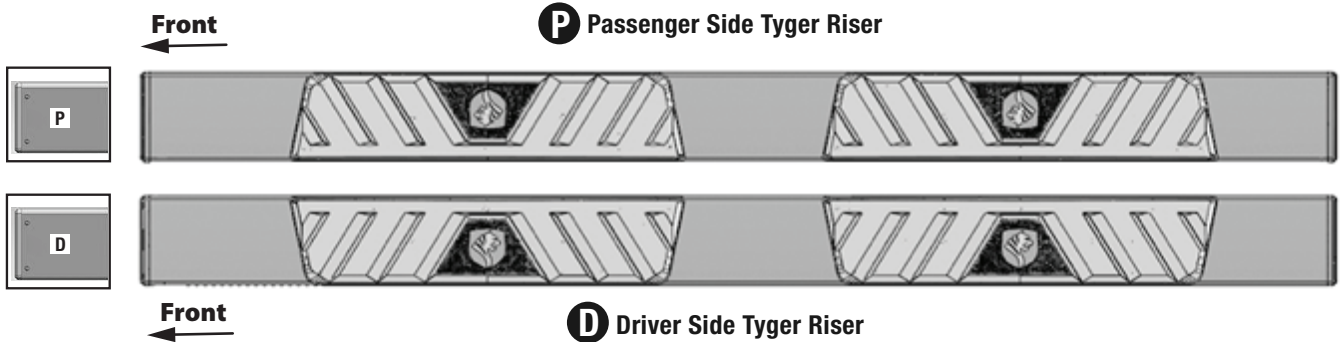

Reference the letters printed on the brackets to determine mounting locations

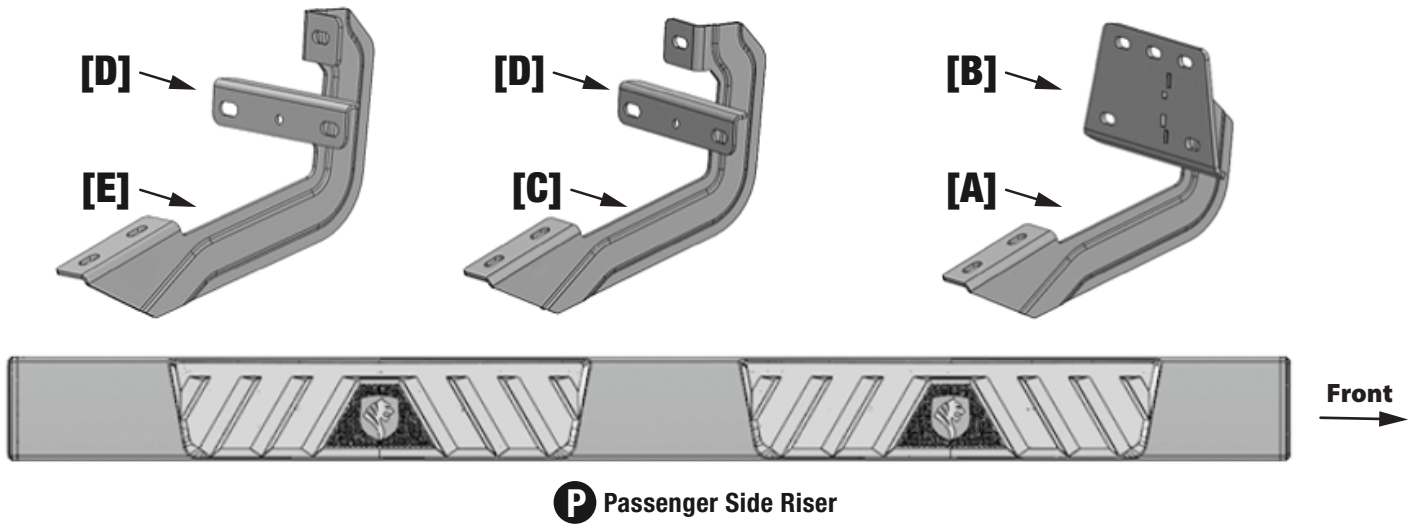
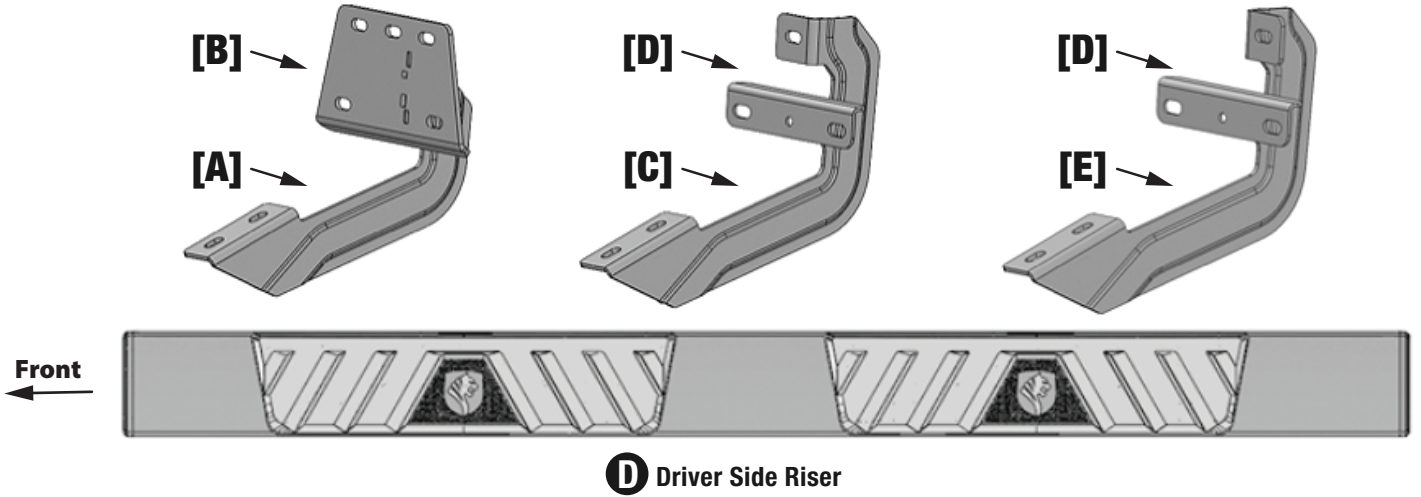

Bottom View

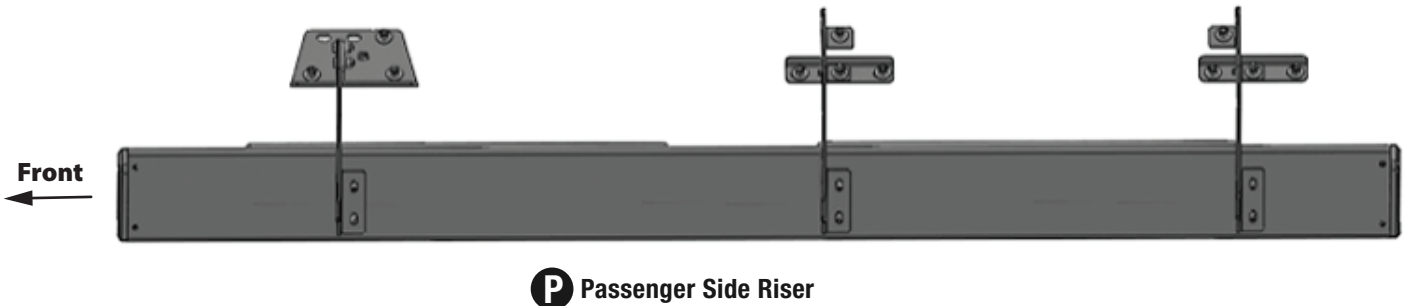
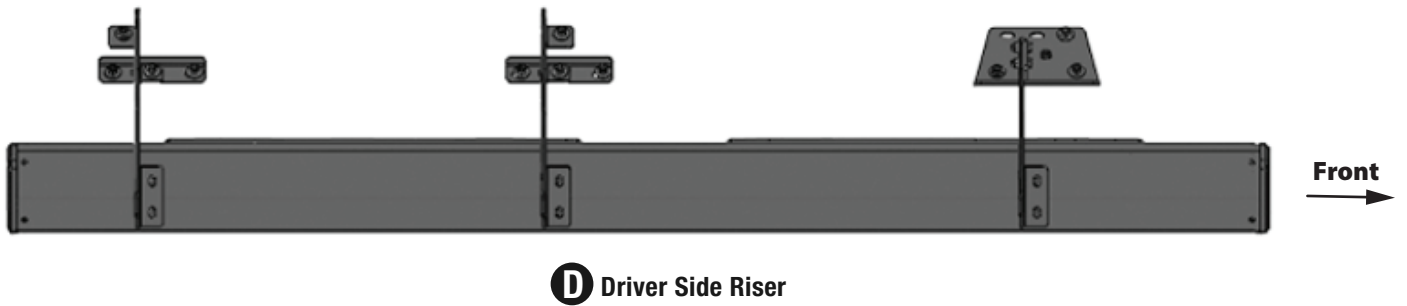

TOOLS REQUIRED

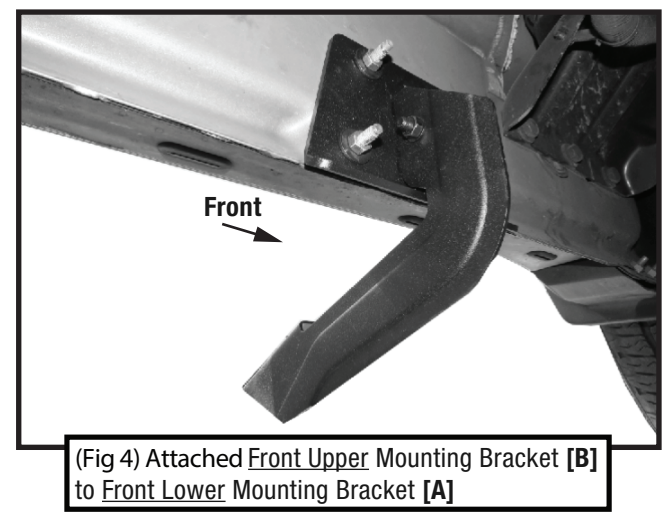
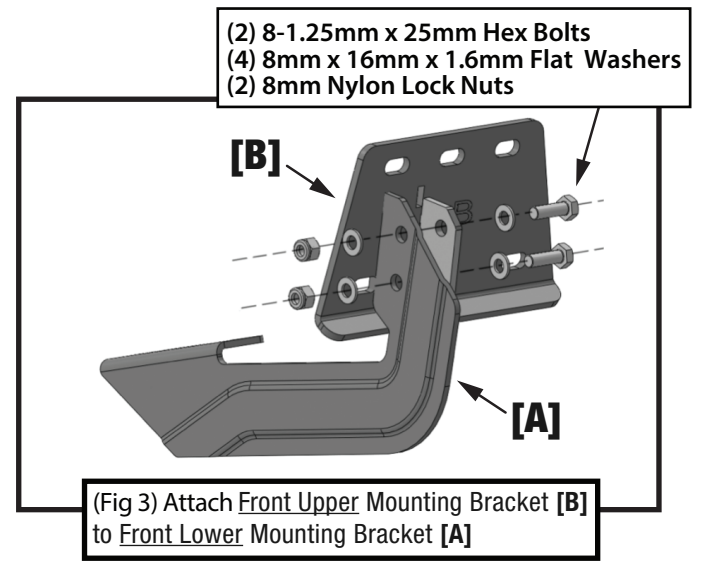
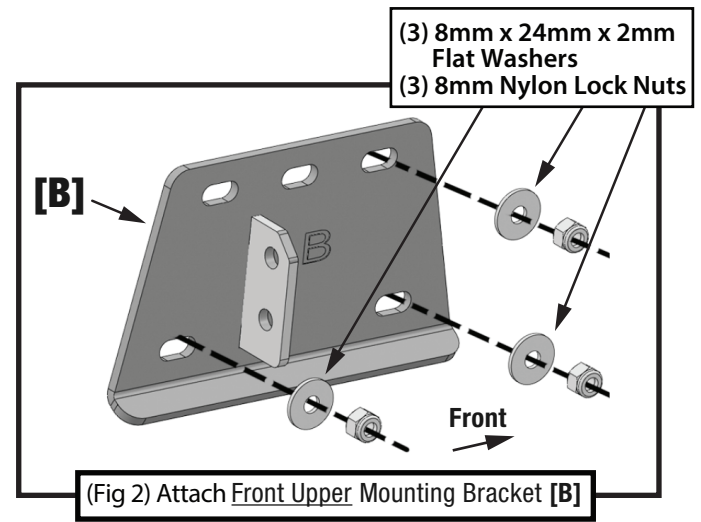
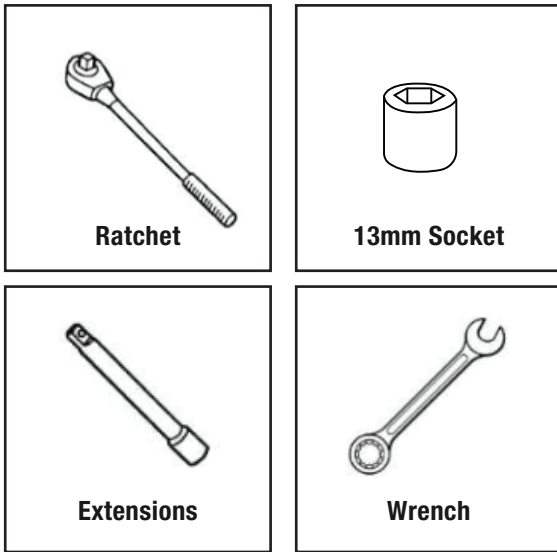

STEP 1 MOUNTING BRACKETS

Follow (Fig 1 – 12) to attach the Mounting Brackets to the Driver Side.

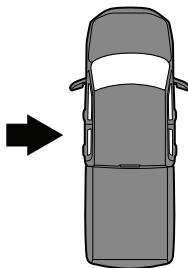

 **Driver-side Front Mounting Area**

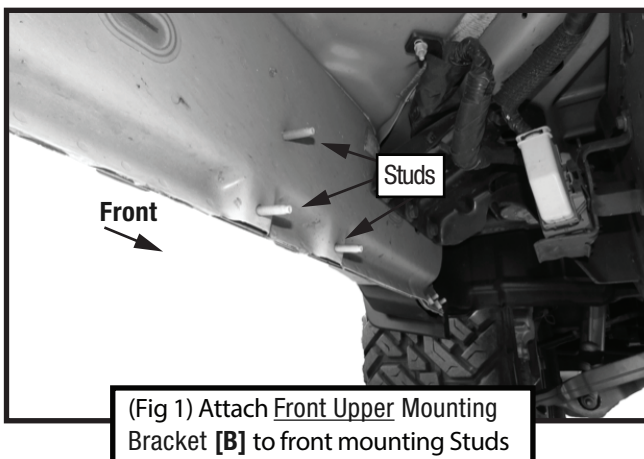

Driver-side Center Mounting Area

Driver-side Rear Mounting Area

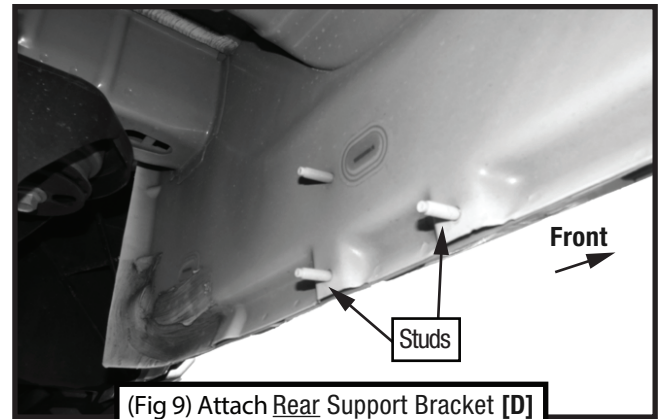
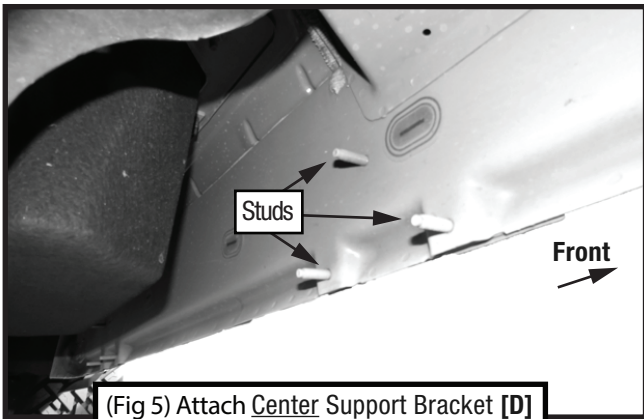

(Fig 5) Attach Center Support Bracket [D] to Center mounting Studs

(Fig 9) Attach Rear Support Bracket [D] to Rear mounting Studs

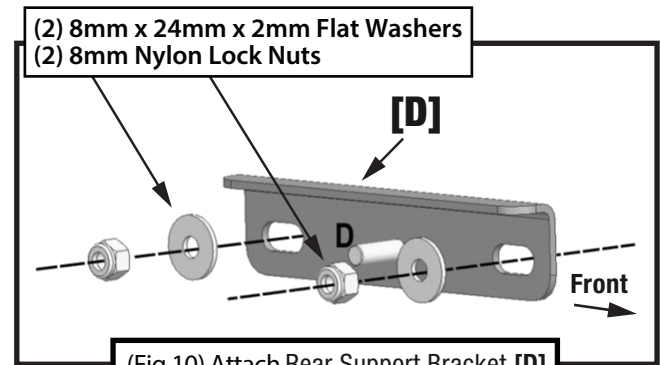
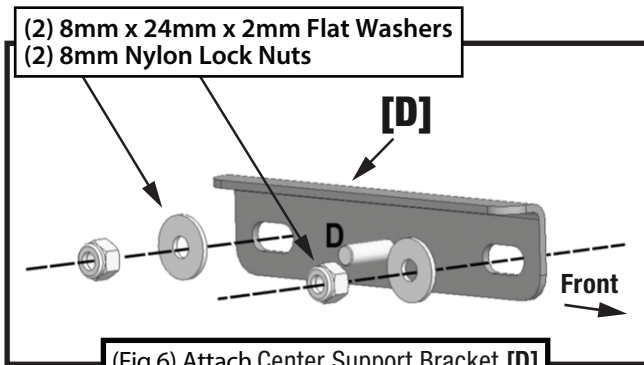

(Fig 6) Attach Center Support Bracket [D]

(Fig 10) Attach Rear Support Bracket [D]

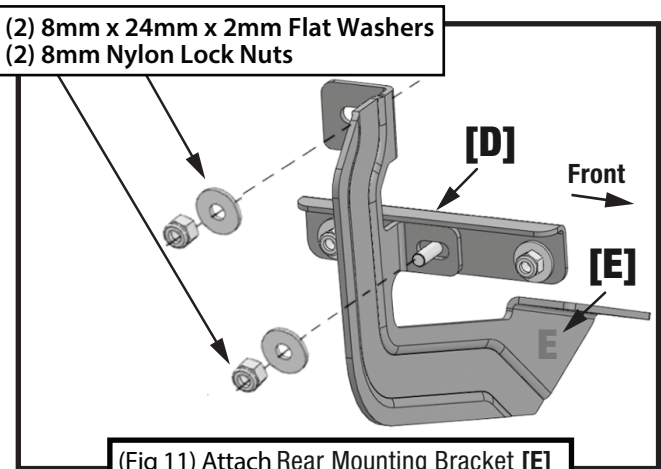
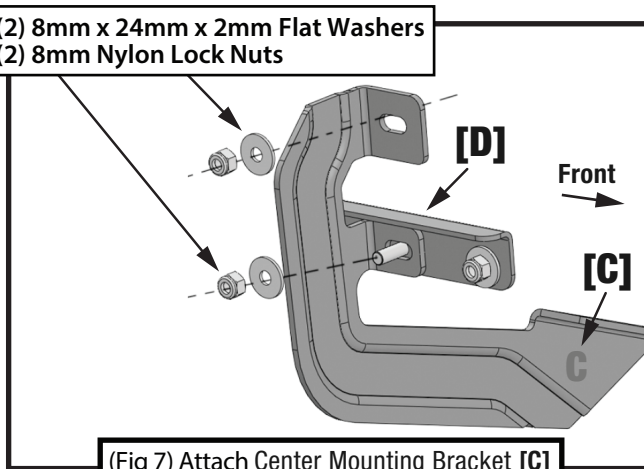

(Fig 7) Attach Center Mounting Bracket [C] to Center Support Bracket [D]

(Fig 11) Attach Rear Mounting Bracket [E] to Rear Support Bracket [D]

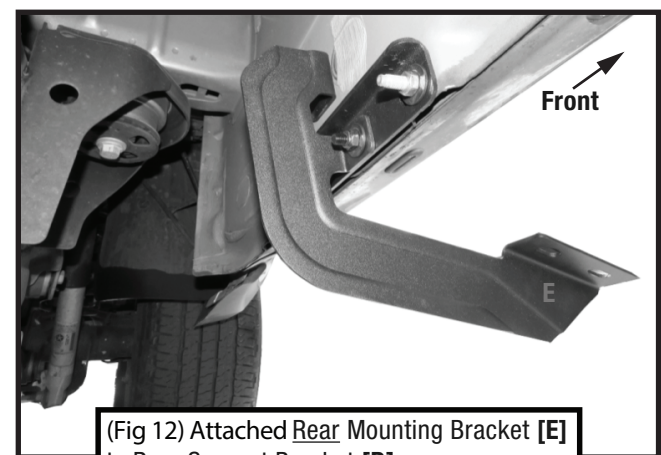
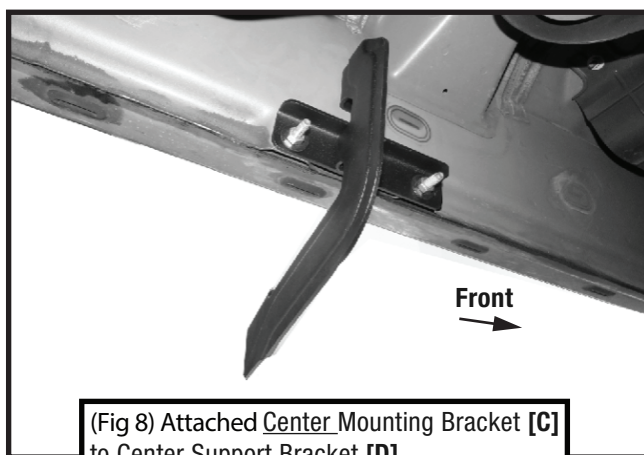

(Fig 8) Attached Center Mounting Bracket [C] to Center Support Bracket [D]

(Fig 12) Attached Rear Mounting Bracket [E] to Rear Support Bracket [D]

STEP 2

Follow (Fig 13) to install the running board.

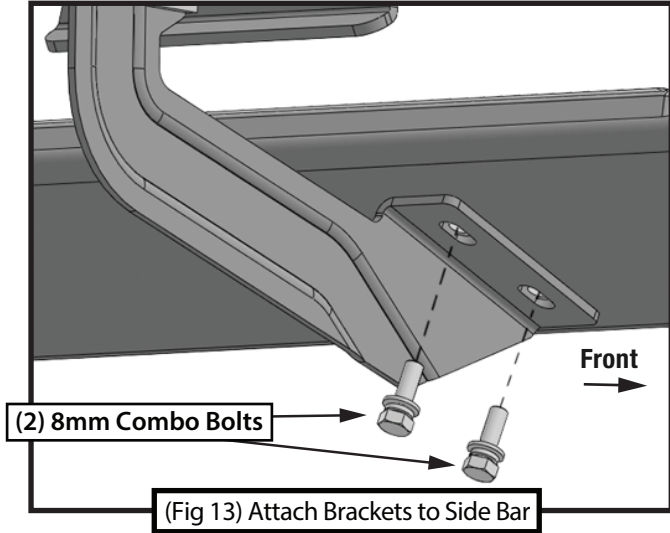

STEP 3 PASSENGER SIDE

Repeat **STEPS 1-2** for passenger side installation.

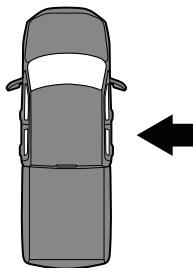

STEP 4

Installation is complete. Do periodic inspections to the installation to make sure that all hardware is secure and tight.