



# RISER®

TG-RS6T60158

## BEFORE INSTALLATION

READ INSTRUCTIONS CAREFULLY BEFORE STARTING INSTALLATION. REMOVE CONTENTS FROM BOX AND VERIFY ALL PARTS ARE PRESENT. FAILURE TO IDENTIFY DAMAGE BEFORE INSTALLATION COULD LEAD TO A REJECTION OF ANY CLAIM. IF MISSING PARTS OR ANY DAMAGE FOUND, PLEASE TAKE A PICTURE FOR THE CLAIM PURPOSE. TO FILE YOUR CLAIM, PLEASE VISIT: [WWW.TYGERAUTO.COM/CONTACT](http://WWW.TYGERAUTO.COM/CONTACT)

## TORQUE VALUES

Fastener Size	Class 8.8 Torque (ft-lbs)	Class 10.9 Torque (ft-lbs)
6mm	6-7	6-7
8mm	15-16	22-23
10mm	31-32	44-45
12mm	54-55	78-79
14mm	87-88	125-126

- x1 Driver Side Riser **[D]**
- x1 Passenger Side Riser **[P]**
- x1 Driver Side Front Mounting Brackets **[A]**
- x1 Driver Side Center Mounting Brackets **[B]**
- x1 Driver Side Rear Mounting Brackets **[C]**
- x1 Passenger Side Front Mounting Bracket **[D]**

- x1 Passenger Side Center Mounting Bracket **[E]**
- x1 Passenger Side Rear Mounting Bracket **[F]**
- x12 8-1.25mm x 25mm Combo Hex Bolts
- x12 8-1.25mm x 30mm Hex Bolts
- x12 8mm Lock Washers
- x12 8mm x 24m x 2mm Flat Washers

Parts List

## Top View

**ATTENTION:** Refer to **[D]** and **[P]** labelling on the side of the tubes to determine Driver and Passenger Riser



Front  
←

**[P]** Passenger Side Riser



Front  
←

**[D]** Driver Side Riser

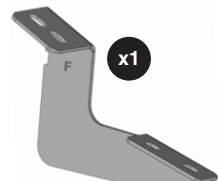
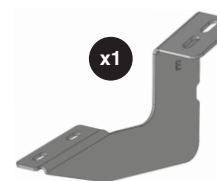
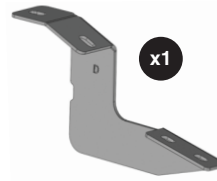
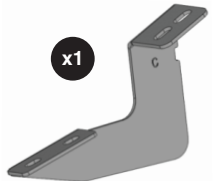
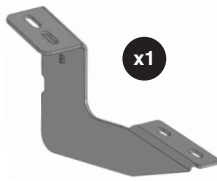
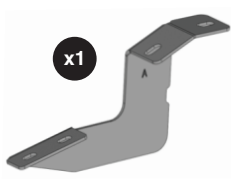

**[A]**  
Driver Side  
Front Mounting Bracket

**[B]**  
Driver Side  
Center Mounting Bracket

**[C]**  
Driver Side  
Rear Mounting Bracket

**[D]**  
Passenger Side  
Front Mounting Bracket

**[E]**  
Passenger Side  
Center Mounting Bracket

**[F]**  
Passenger Side  
Rear Mounting Bracket

x12



Combo Bolts

x12



Hex Bolts

x12



Flat Washers

x12



Lock Washers

Reference the letters printed on the brackets to determine mounting locations

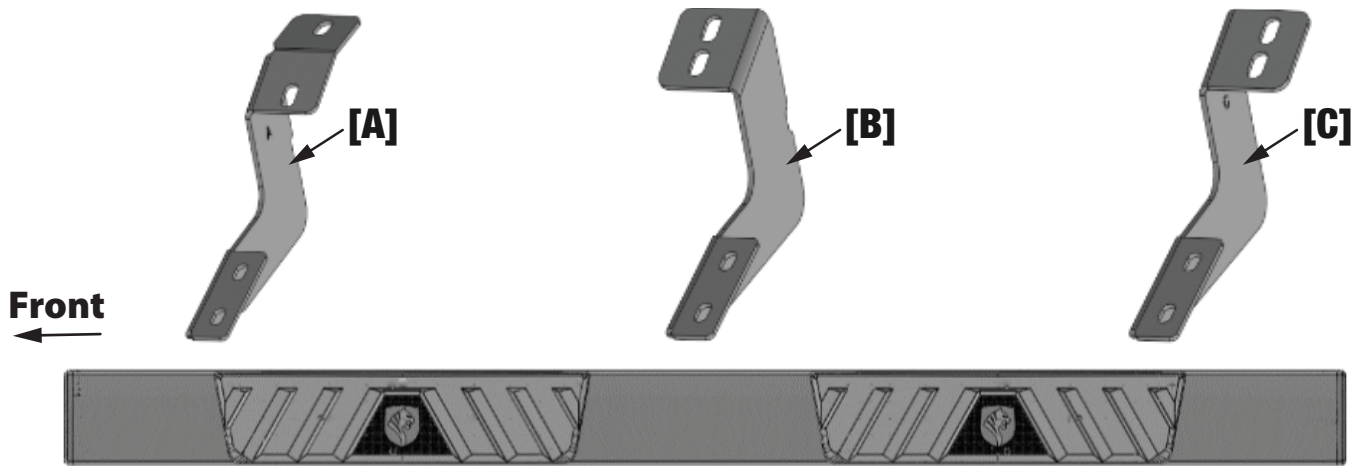

**D** Driver Side Riser

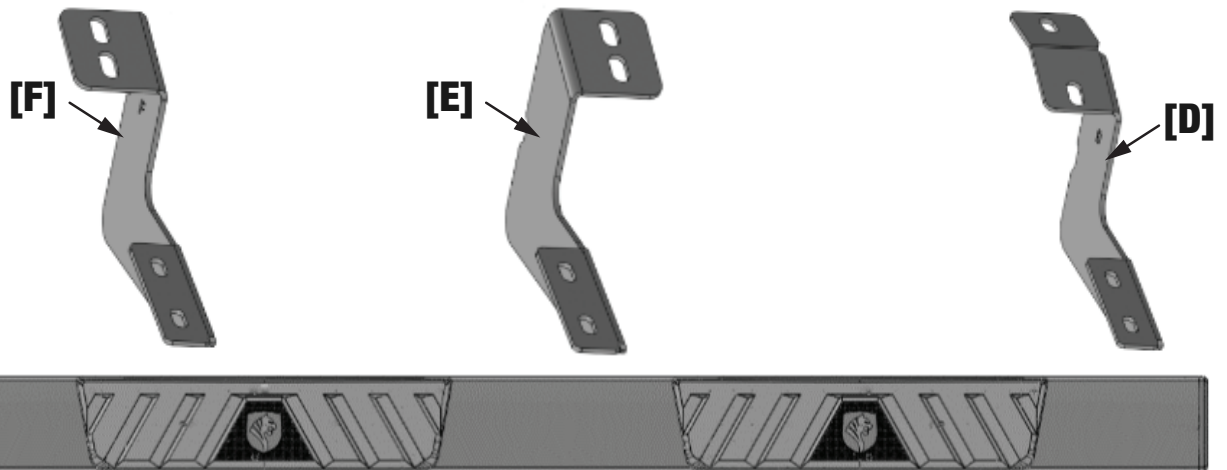

**P** Passenger Side Riser

**Bottom View**

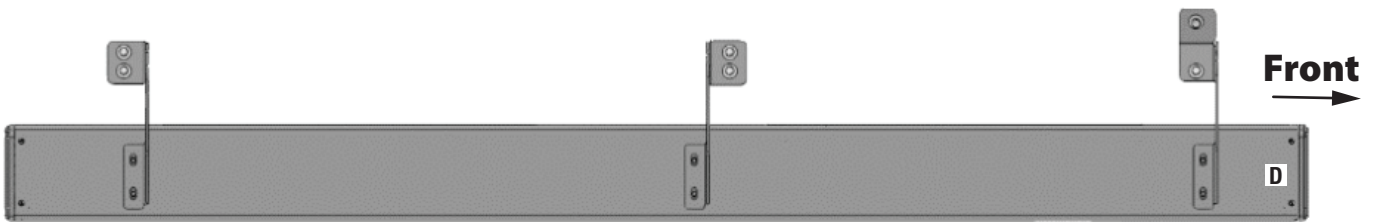

**D** Driver Side Riser

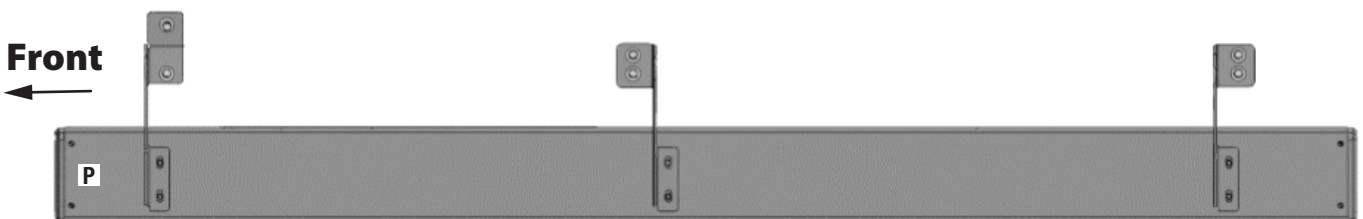

**P** Passenger Side Riser

## TOOLS REQUIRED

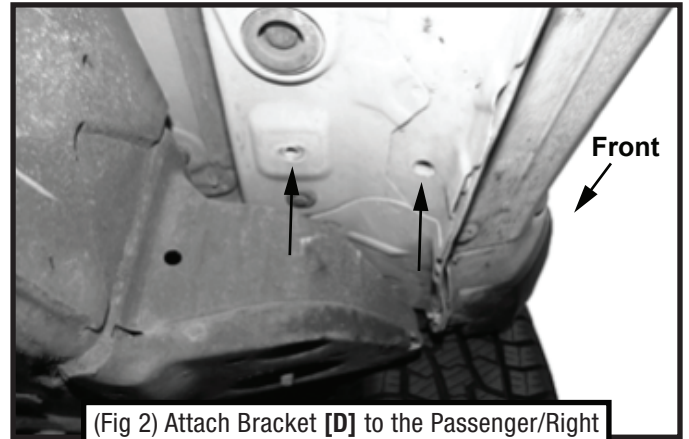
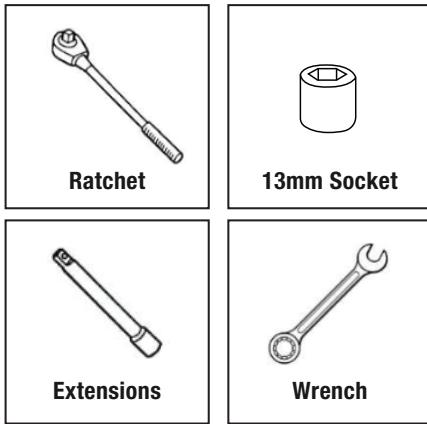

(Fig 2) Attach Bracket [D] to the Passenger/Right Side front mounting location

## STEP 1 MOUNTING BRACKETS

Follow (Fig 1 – 10) to attach the Brackets to the Passenger Side. Remove factory studs from vehicle mounting points prior to installing mounting brackets.

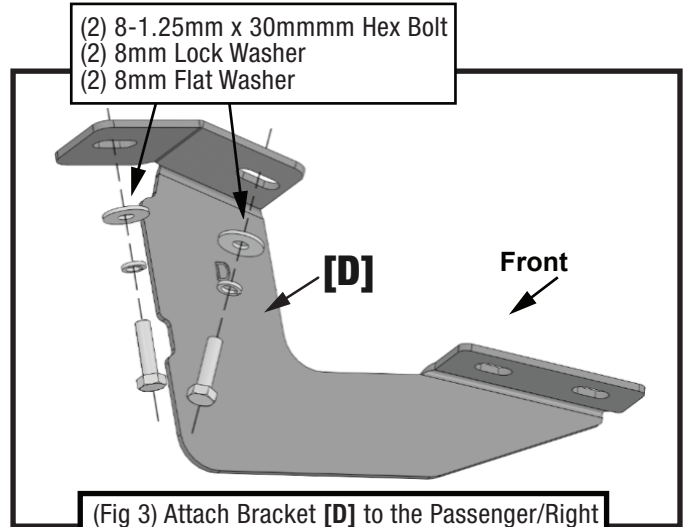
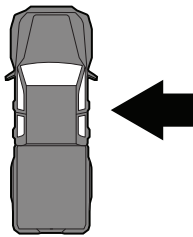

(Fig 3) Attach Bracket [D] to the Passenger/Right Side front mounting location

### 📍 Passenger-side Front Mounting Area

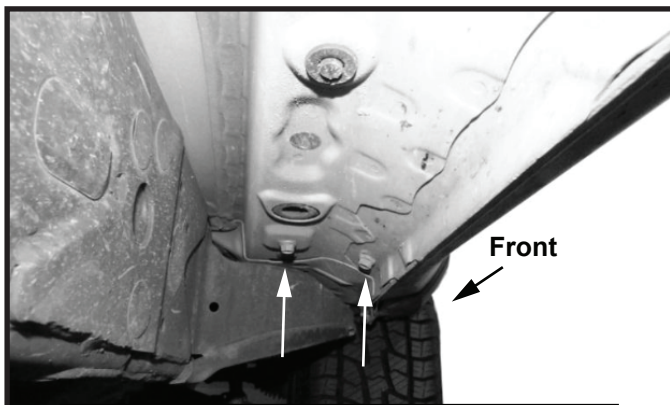

(Fig 1) Remove factory studs from vehicle mounting points prior to installing mounting brackets

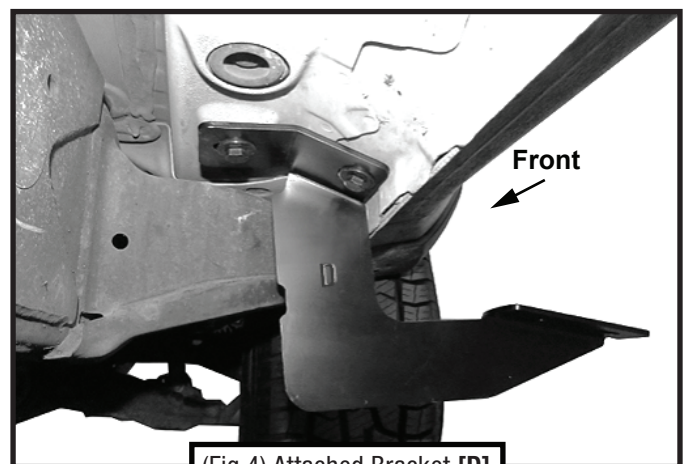

(Fig 4) Attached Bracket [D]

**Passenger-side Center Mounting Area**

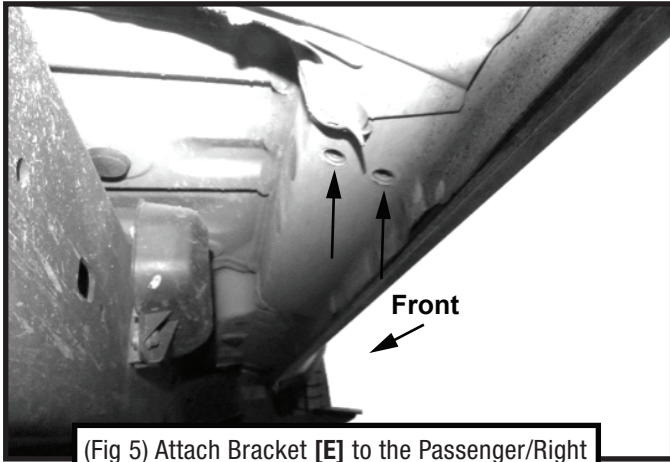

(Fig 5) Attach Bracket [E] to the Passenger/Right side center mounting location

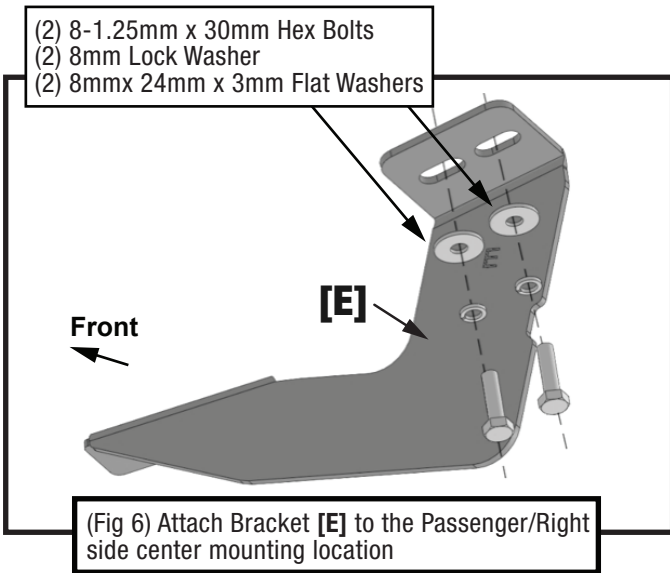

(Fig 6) Attach Bracket [E] to the Passenger/Right side center mounting location

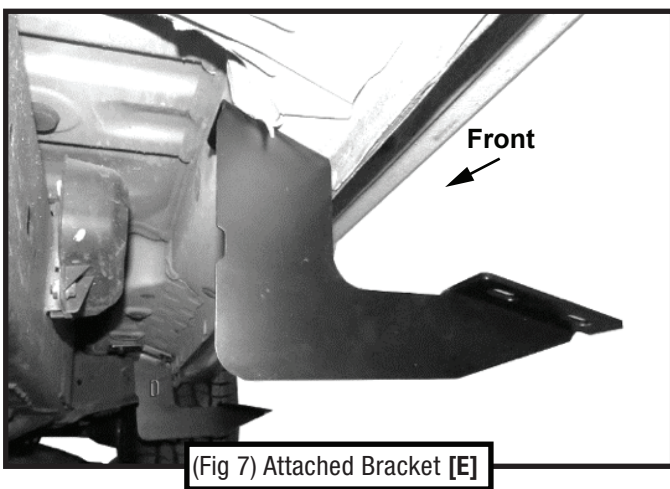

(Fig 7) Attached Bracket [E]

**Passenger-side Rear Mounting Area**

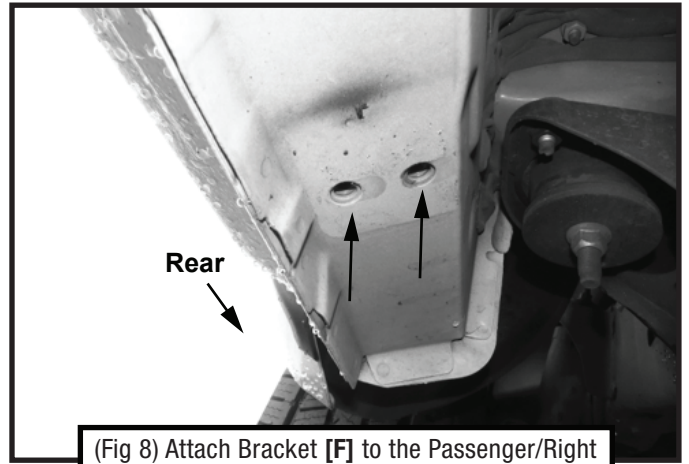

(Fig 8) Attach Bracket [F] to the Passenger/Right side rear mounting location

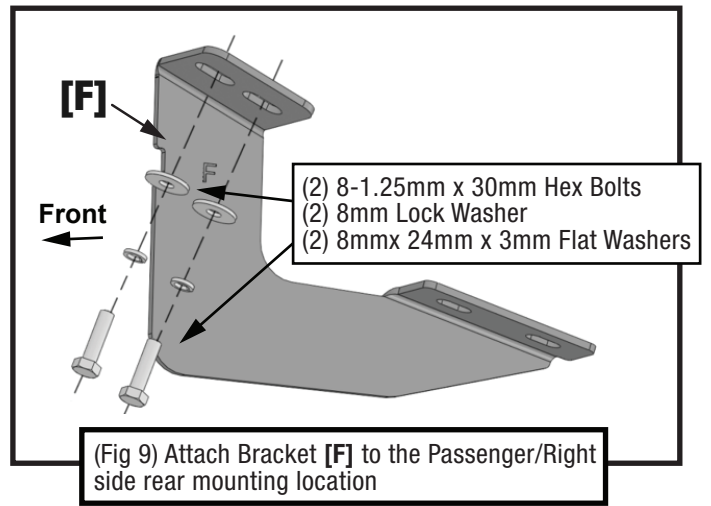

(Fig 9) Attach Bracket [F] to the Passenger/Right side rear mounting location

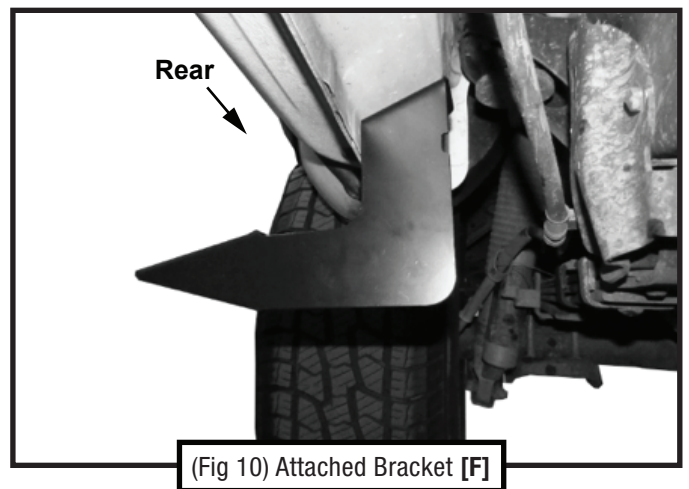

(Fig 10) Attached Bracket [F]



## STEP 2 MOUNTING RUNNING BOARDS

Follow (Fig 11) to install the Passenger Side Running Board onto each installed Bracket.

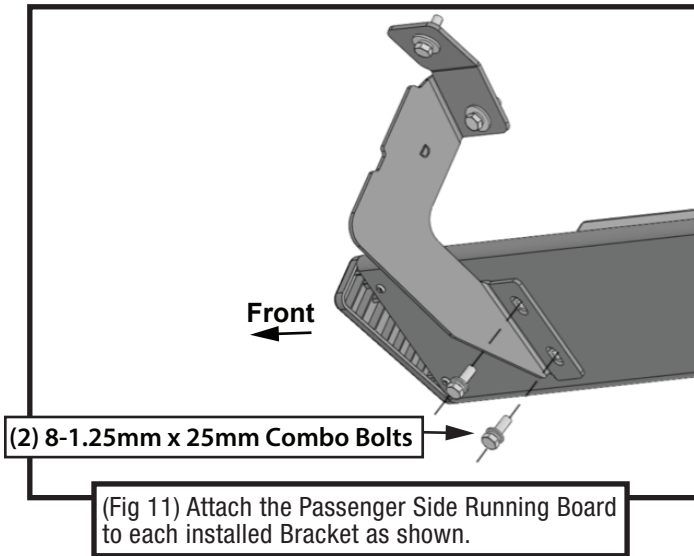

## STEP 4

Installation is complete. Do periodic inspections to the installation to make sure that all hardware is secure and tight.

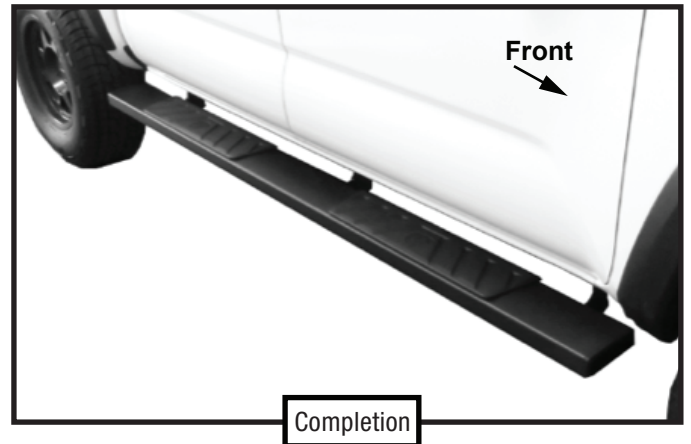

## STEP 3 DRIVER SIDE

Repeat **STEPS 1-2** for driver side installation.

Use Bracket **[A]** instead of **[D]**;

Use Bracket **[B]** instead of **[E]**;

Use Bracket **[C]** instead of **[F]**.

