



TYGER SPORT BAR

TG-SB7F88838

BEFORE INSTALLATION

READ INSTRUCTIONS CAREFULLY BEFORE STARTING INSTALLATION. REMOVE CONTENTS FROM BOX AND VERIFY ALL PARTS ARE PRESENT. FAILURE TO IDENTIFY DAMAGE BEFORE INSTALLATION COULD LEAD TO A REJECTION OF ANY CLAIM. IF MISSING PARTS OR ANY DAMAGE FOUND, PLEASE TAKE A PICTURE FOR THE CLAIM PURPOSE. TO FILE YOUR CLAIM, PLEASE VISIT:

WWW.TYGERAUTO.COM/CONTACT

TORQUE VALUES

Fastener Size	Class 8.8 Torque (ft-lbs)	Class 10.9 Torque (ft-lbs)
6mm	6-7	6-7
8mm	15-16	22-23
10mm	31-32	44-45
12mm	54-55	78-79
14mm	87-88	125-126

- x1** Front Cross Tube
- x1** Driver/Left Support Tube
- x1** Passenger/Right Support Tube
- x1** Driver/Left Decorative Plate
- x1** Passenger/Right Decorative Plate
- x1** Driver/Left Logo Plate
- x1** Passenger/Right Logo Plate
- x2** Rubber Plugs
- x2** LED Light Bar Brackets
- x1** Driver/Left Base Bracket
- x1** Passenger/Right Base Bracket
- x1** Driver/Left Top Plastic Sleeve
- x1** Passenger/Right Top Plastic Sleeve
- x4** Plastic Base Covers
- x1** Edge Trim for Base Brackets
- x1** 12mm Fish Wire
- x2** 12-1.5mm x 60mm Button Head Bolts
- x4** 12-1.75mm x 35mm Flat Head Bolts
- x2** 12mm x 24mm x 2.5mm Flat Washers
- x2** 12mm Lock Washers
- x6** 8mm Nut Plates
- x6** 8-1.25mm x 40mm Hex Bolts
- x2** 8-1.25mm x 25mm Hex Bolts
- x2** 8-1.25mm x 16mm Hex Bolts
- x12** 8mm x 24mm x 2mm Flat Washers
- x10** 8mm Lock Washers
- x2** 8mm Hex Nuts
- x2** 6mm Button Head Combo Bolts
- x8** 6mm Flange Nuts
- x1** 8mm Hex Wrench
- x1** 4mm Hex Wrench

Parts List

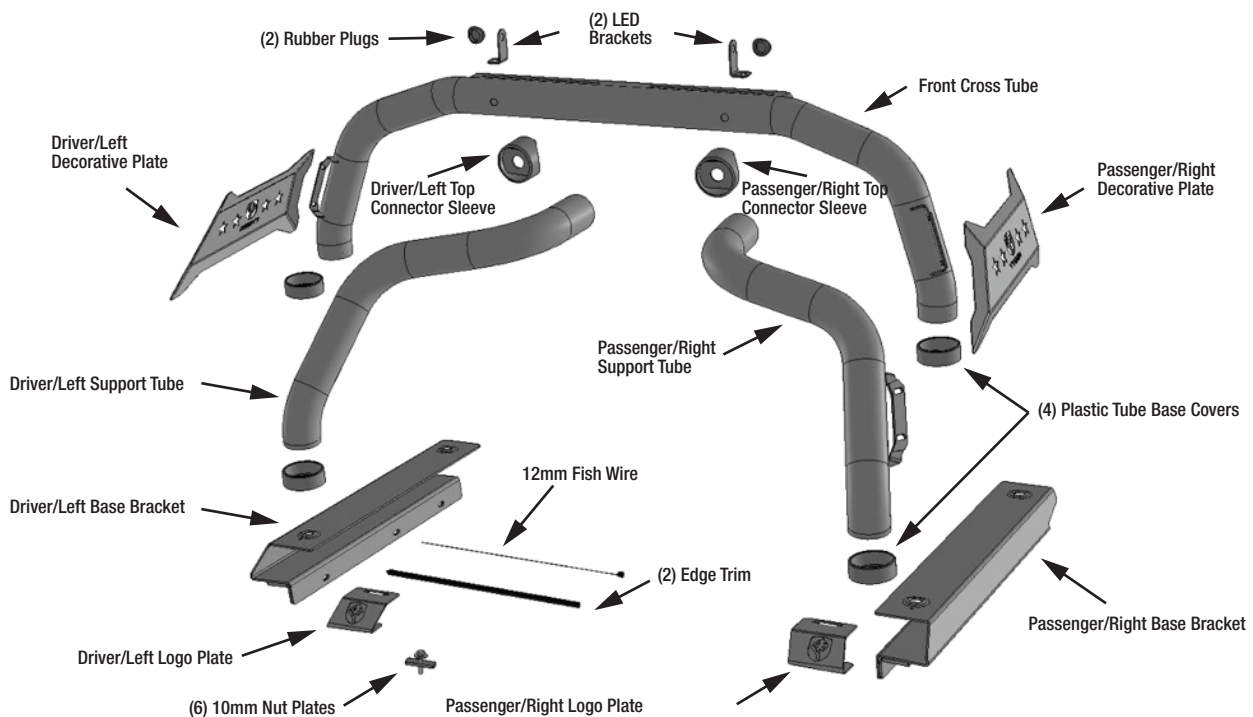

PROCEDURE:

REMOVE CONTENTS FROM BOX. VERIFY ALL PARTS ARE PRESENT. READ INSTRUCTIONS CAREFULLY BEFORE STARTING INSTALLATION. ASSISTANCE IS RECOMMENDED. DRILLING IS REQUIRED.

STEP 1

Slide (1) 12mm Lock Washer and (1) 12mm Flat Washer onto (1) 12mm x 60mm Button Head Bolt. Thread the bolt assembly into the 12mm Fish Wire (Fig 1).

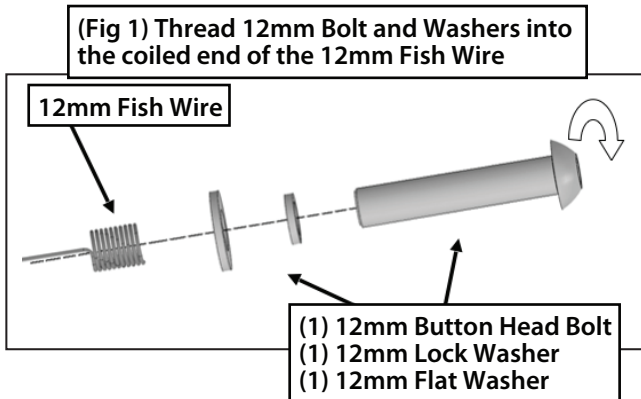
STEP 2

Select the Front Cross Tube. Guide the straight end of the Fish Wire through the holes in passenger/right side of the Cross Tube (Figs 2 & 3). Pull the 12mm Bolt through the Front Cross Tube. Insert 8mm Hex Wrench into the head of the Bolt to hold it in place inside the tube. Remove the Fish Wire (Figs 3 & 4).

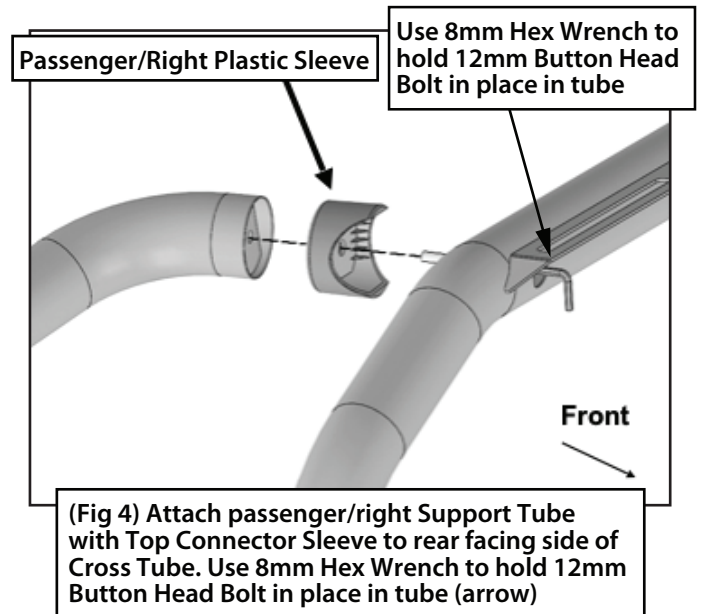
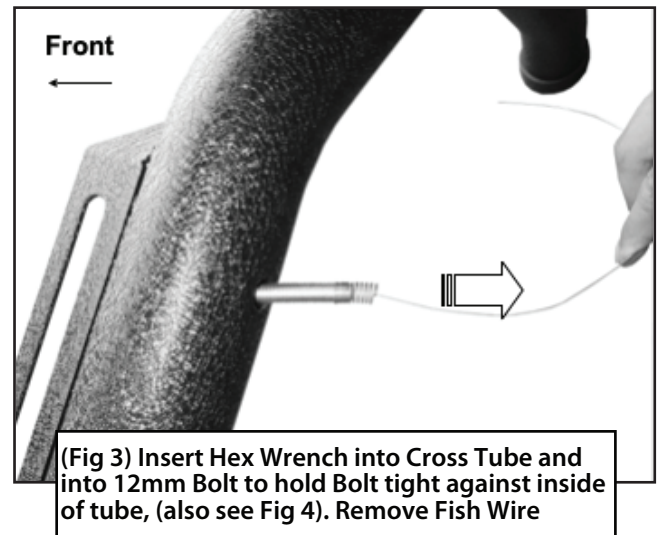
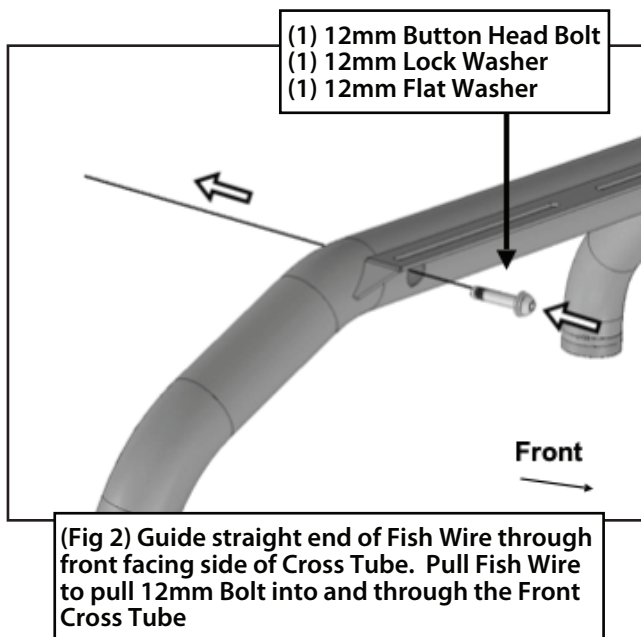
STEP 3

Slide the Passenger/ Right Plastic Sleeve onto the top end of the Passenger/Right Support Tube. Thread the 12mm Button Head Bolt into the Support Tube (Figs 4 & 5). DO NOT fully tighten.

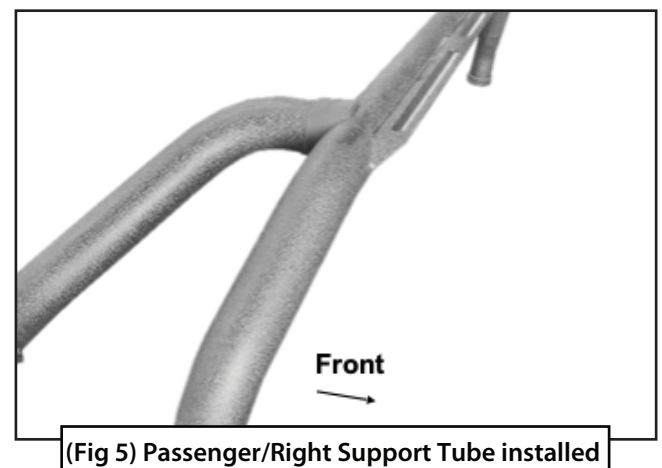

STEP 4

Repeat **STEPS 1-3** to attach the Driver/Left Support Tube to the Cross Tube.

STEP 5

Slide (2) Plastic Base Covers onto the bottom of the passenger/right side of the Cross Tube and Support tubes, (Fig 6). Select the Passenger/Right Base Bracket. Attach the Base Bracket to the bottom of the Tubes with (2) 12mm x 35mm Flat Head Bolts (Fig 6). **DO NOT** tighten hardware.

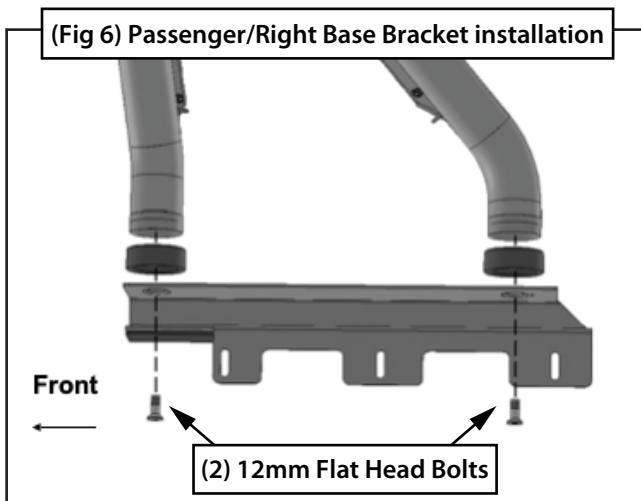

STEP 6

Select the Passenger/Right Decorative Plate. Attach the Plate to the welded brackets on the sides of the tubes with (4) 6mm Flanged Hex Nuts (Figs 7 & 8).

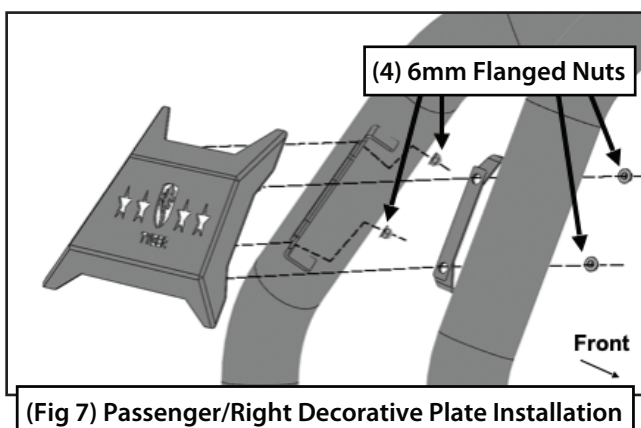

(Fig 8) Passenger/Right Decorative Plate installed

STEP 7

Push the included Edge Trim onto the forward facing edge of the Base Bracket (Fig 9). Cut Edge Trim to fit.

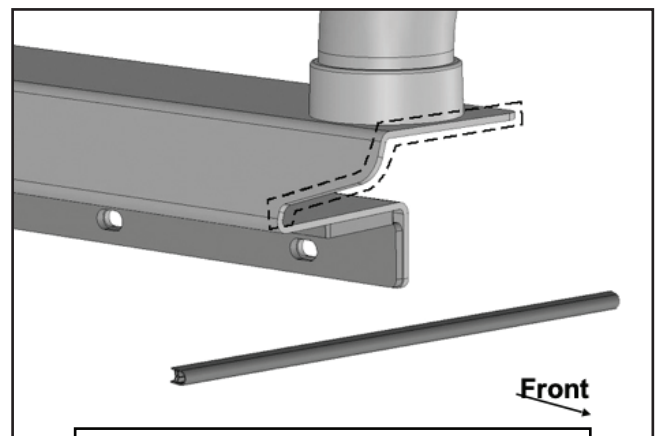

(Fig 9) Push Edge Trim onto the front facing edge of the Base Bracket. Cut to fit.

STEP 8

Repeat **STEPS 5-7** to attach Driver/Left Base Bracket and Decorative Plate.

STEP 9

With assistance, place the Sports Bar assembly onto the desired position on the bed of the vehicle. Line up the Sport Bar with the vehicle and fully tighten all hardware. The front of the Cross Tube should be at least 30mm away from the rear of the cab. Select (2) Rubber Plugs. Insert the Plugs into the holes in the front facing side of the Cross Tube (Fig 10).

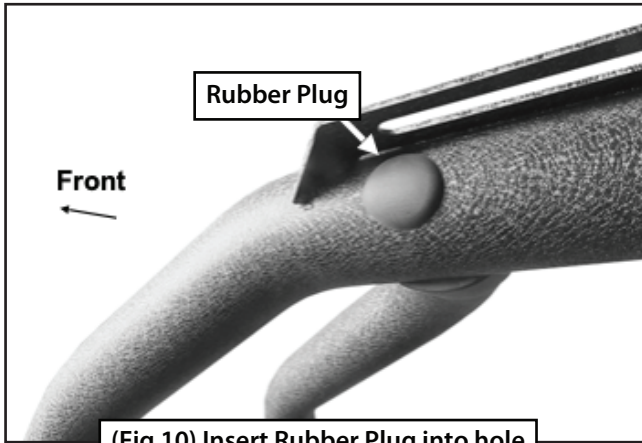

(Fig 10) Insert Rubber Plug into hole

STEP 10

Mark the holes in the Base Brackets to determine locations to drill holes in the lip of the bed (Figs 11 & 12). Check to make sure the back of the edge of the bed is accessible before drilling. Repeat this STEP to mark the Driver/Left side of the Sports Bar.

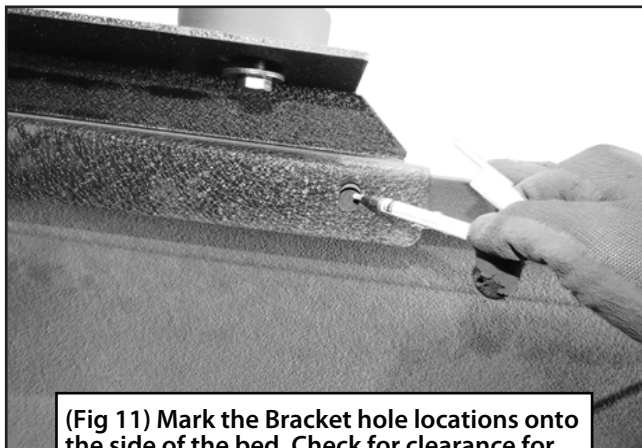

(Fig 11) Mark the Bracket hole locations onto the side of the bed. Check for clearance for hardware behind edge of bed before drilling

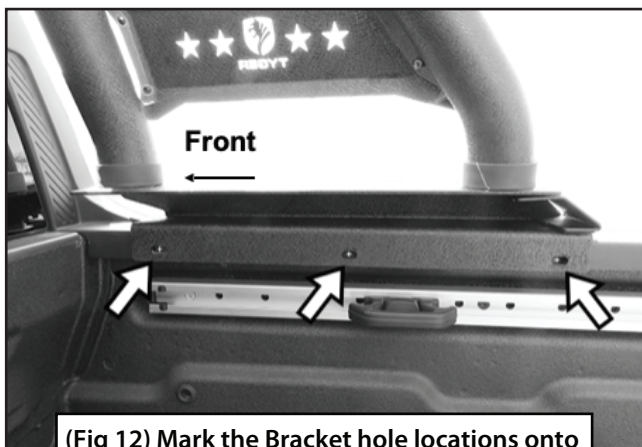

(Fig 12) Mark the Bracket hole locations onto the side of the bed (arrow)

STEP 11

Temporarily remove the Sports Bar. Using a 5/16" drill bit, drill all holes for mounting (Figs 13 & 14). **IMPORTANT:** DO NOT drill too closely to the edge of the bed. To Prevent rust, apply a thin layer of paint over the exposed metal.

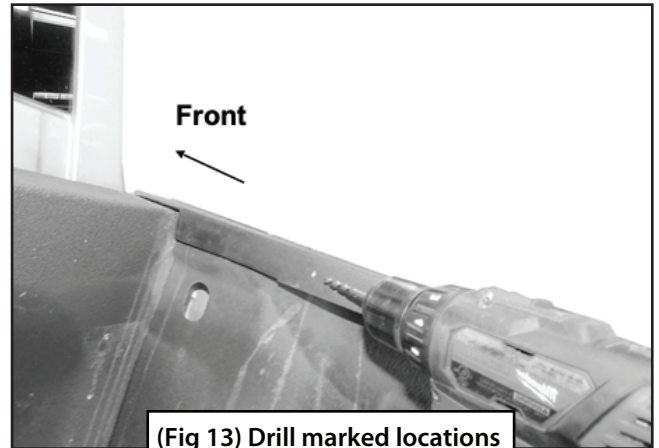

(Fig 13) Drill marked locations with a 5/16" drill bit

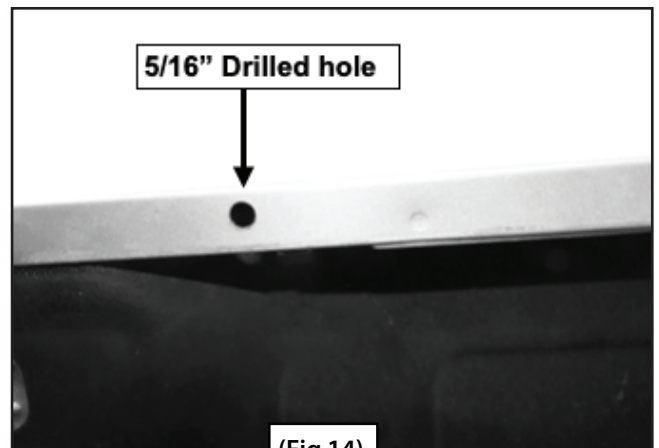

(Fig 14)

STEP 12

Attach the passenger/right side of the Sports Bar assembly to the bed with (3) 8mm x 40mm Hex Bolts, (3) 8mm Lock Washers, (3) 8mm Flat Washers and (3) 8mm Nut Plates, (hold nut plates up to back of edge of bed) (Fig 15). Repeat this STEP to attach the driver/left side of the Sports Bar.

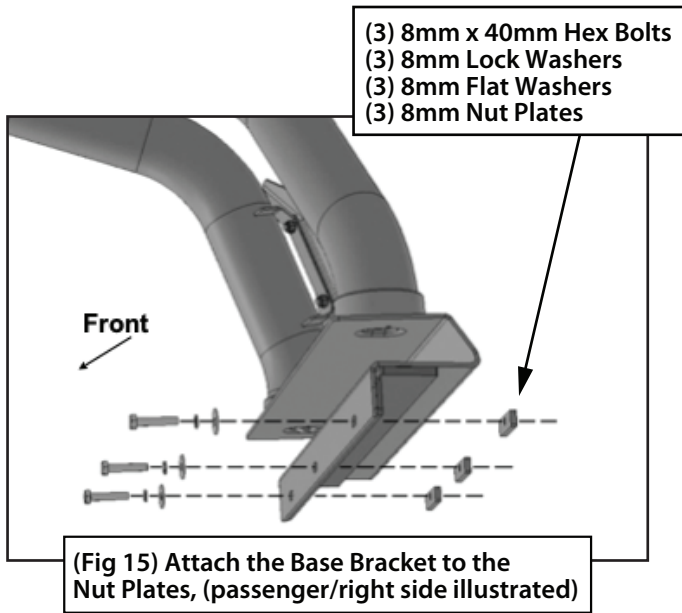

STEP 13

Select (1) LED Light Bracket. Attach to the top of the Sports Bar with (1) 8mm x 25mm Hex Bolt, (2) 8mm Flat Washers, (1) 8mm Lock Washer and (1) 8mm Hex Nut (Fig 16). Repeat this STEP to install remaining LED light Bracket. **NOTE:** Installation is optional. Attach LED Light Bar (not included) to the LED Light Bracket with (2) 8mm x 16mm Hex Bolts, (2) 8mm Lock Washers and (2) 8mm Flat Washers (Fig 17).

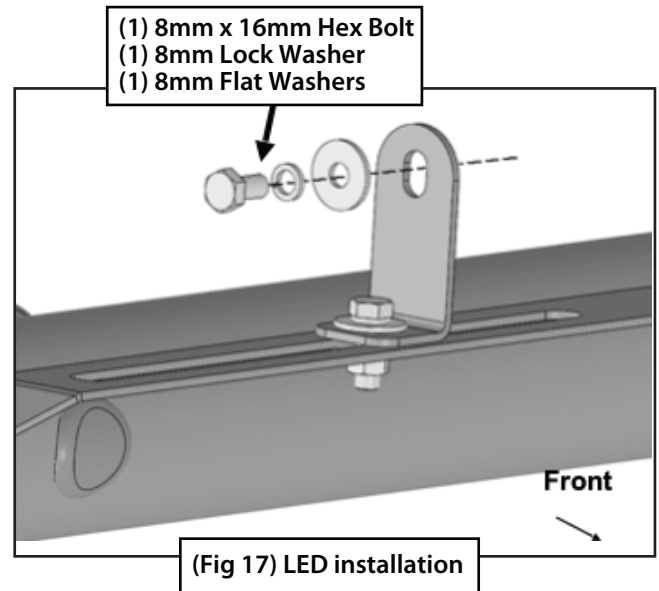
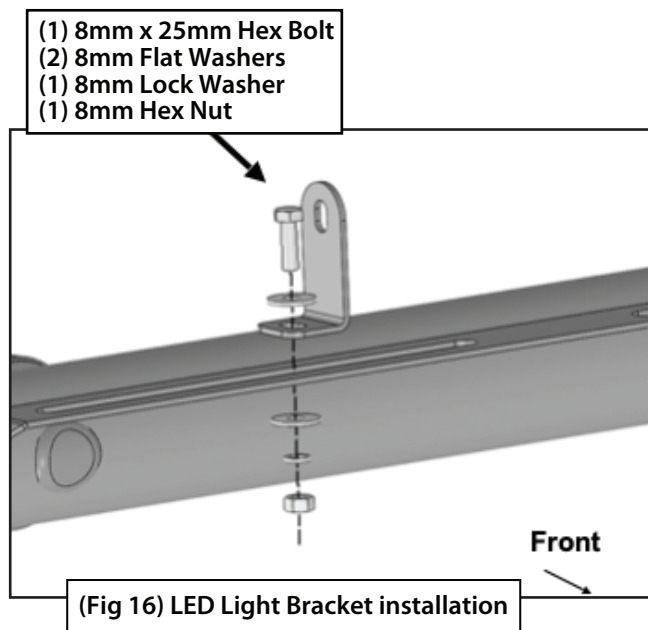

STEP 14

Determine if vehicle is equipped with tonneau cover:

Models with tonneau cover, installation is complete, skip to **STEP 15.**

Models without tonneau cover.

a. Push the Passenger/Right Logo Plate into the Base Bracket, between the rear end of the Bracket and the top of the bed (Fig 18). **NOTE:** Logo Plate installation is optional.

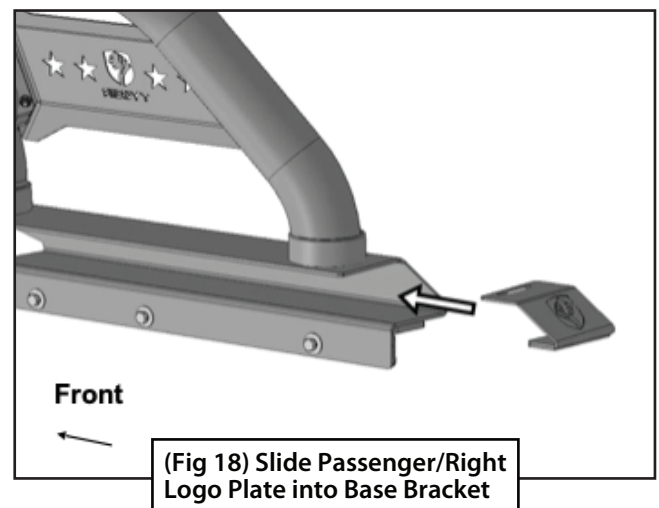

b. Line up the slot in the Logo Plate with the threaded hole in the inside of the Base Bracket. Attach Logo Plate with one 6mm Combo Bolt (Figs 19 & 20).

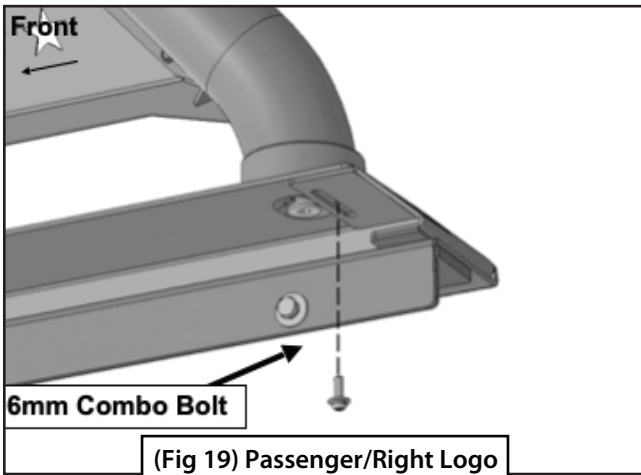

(Fig 19) Passenger/Right Logo Plate installation (Optional)

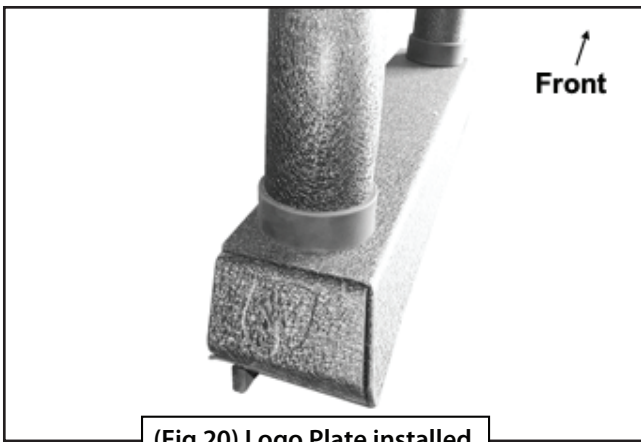

(Fig 20) Logo Plate installed

c.Repeat previous **Steps** to attach the driver/left Logo Plate.

STEP 15

Do periodic inspections to the installation to make sure that all hardware is secure and tight.



Complete Installation