



STAR STRIDER®

TG-SR2C74908

BEFORE INSTALLATION

READ INSTRUCTIONS CAREFULLY BEFORE STARTING INSTALLATION. REMOVE CONTENTS FROM BOX AND VERIFY ALL PARTS ARE PRESENT. FAILURE TO IDENTIFY DAMAGE BEFORE INSTALLATION COULD LEAD TO A REJECTION OF ANY CLAIM. IF MISSING PARTS OR ANY DAMAGE FOUND, PLEASE TAKE A PICTURE FOR THE CLAIM PURPOSE. TO FILE YOUR CLAIM, PLEASE VISIT:

WWW.TYGERAUTO.COM/CONTACT

TORQUE VALUES

Fastener Size	Class 8.8 Torque (ft-lbs)	Class 10.9 Torque (ft-lbs)
6mm	6-7	6-7
8mm	15-16	22-23
10mm	31-32	44-45
12mm	54-55	78-79
14mm	87-88	125-126

- x1** Driver Side Star Strider **[D]**
- x1** Passenger Side Star Strider **[P]**
- x1** Driver Side Front Bracket **[A]**
- x1** Passenger Side Front Bracket **[D]**
- x2** Driver Side Center Brackets **[B]**
- x2** Passenger Side Center Brackets **[E]**
- x1** Driver Side Rear Bracket **[C]**
- x1** Passenger Side Rear Bracket **[F]**
- x8** 8mm Double Bolt Plates
- x32** 8mm x 24mm x 2mm Flat Washers
- x16** 8mm Nylon Lock Nuts
- x16** 8-1.25mm x 30mm Hex Bolts
- x16** 8mm Lock Washers

Parts List

Top View

ATTENTION: Refer to **[D]** and **[P]** labelling on the side of the tubes to determine Driver and Passenger Star Striders



Front

[P] Passenger Side Star Strider



Front

[D] Driver Side Star Strider

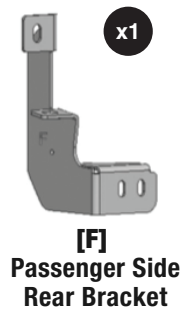
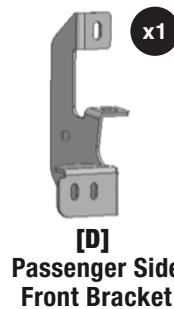
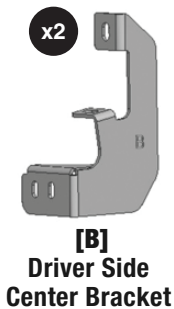

Hex Bolt



Lock Washer



Flat Washer



M8 Nylon Lock Nut

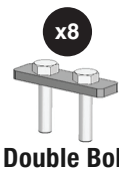

8mm Double Bolt Plate

Reference the letters printed on the brackets to determine mounting locations

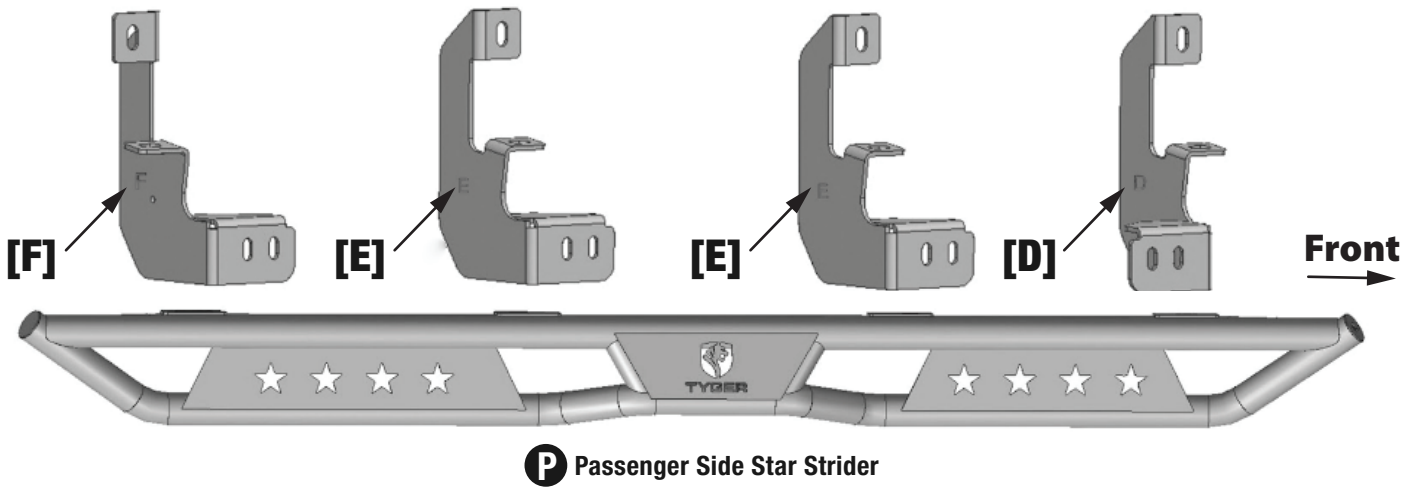
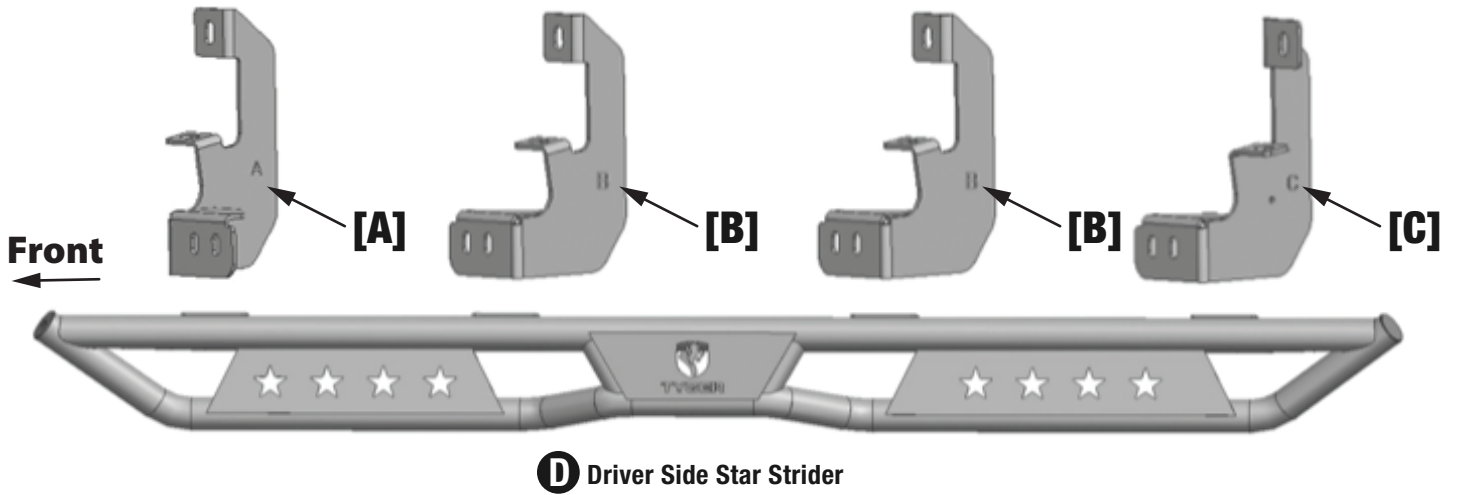

Bottom View

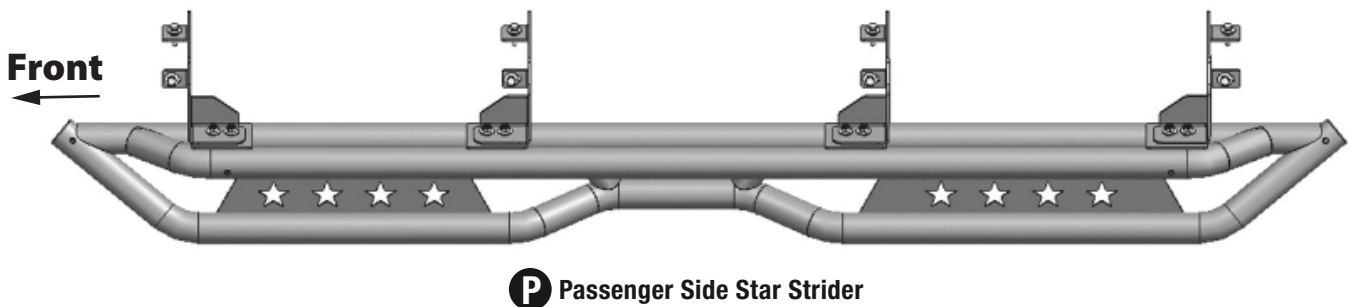
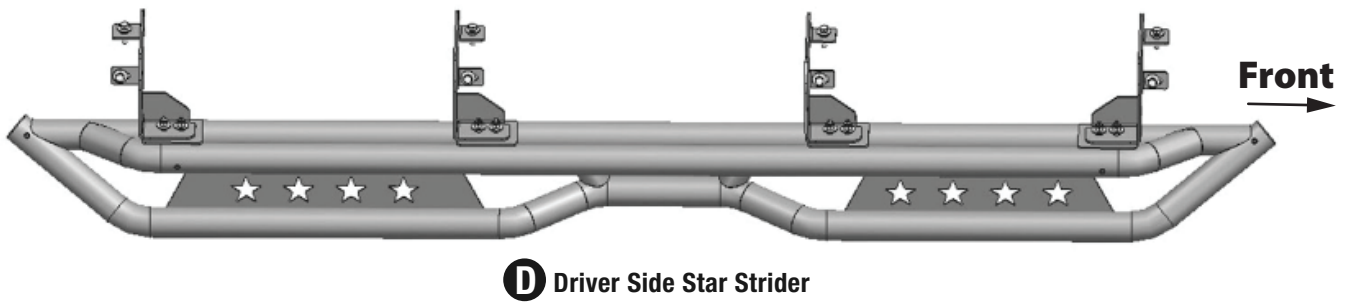

TOOLS REQUIRED

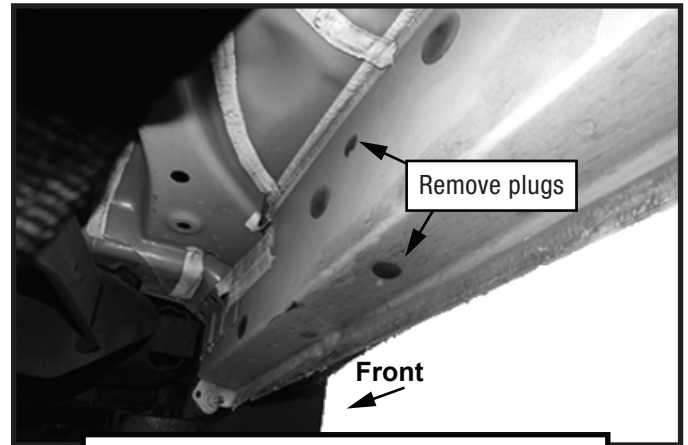
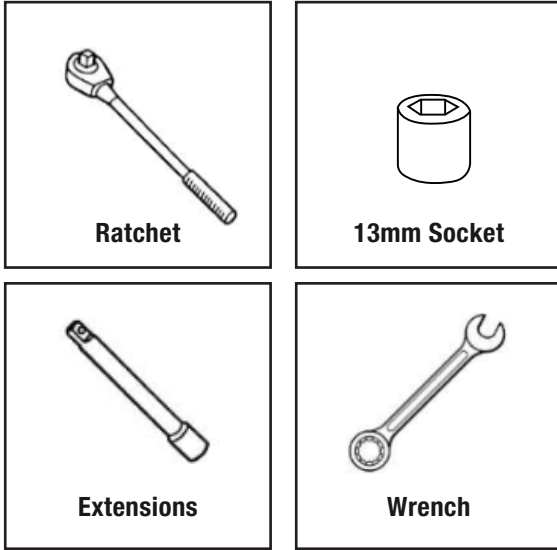

(Fig 2) Remove plastic plugs to uncover threaded inserts at front mounting location (if any)

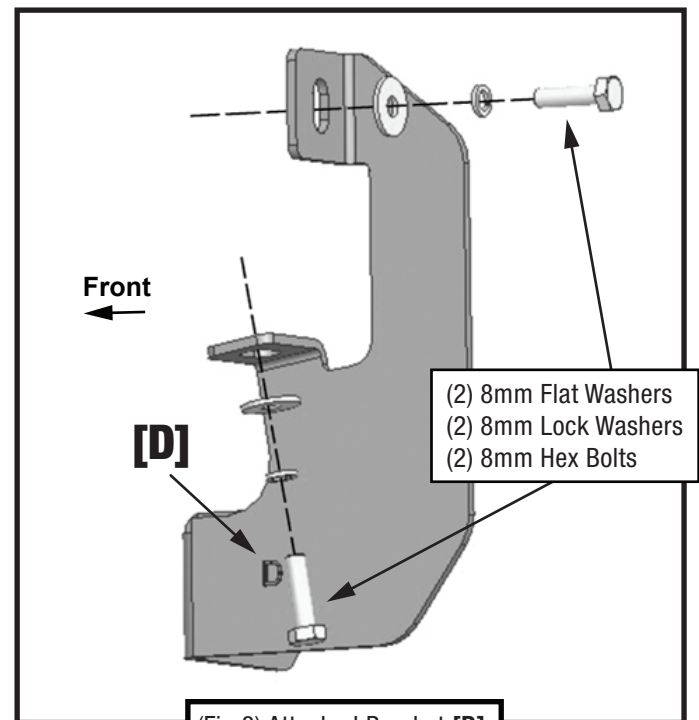

(Fig 3) Attached Bracket [D]

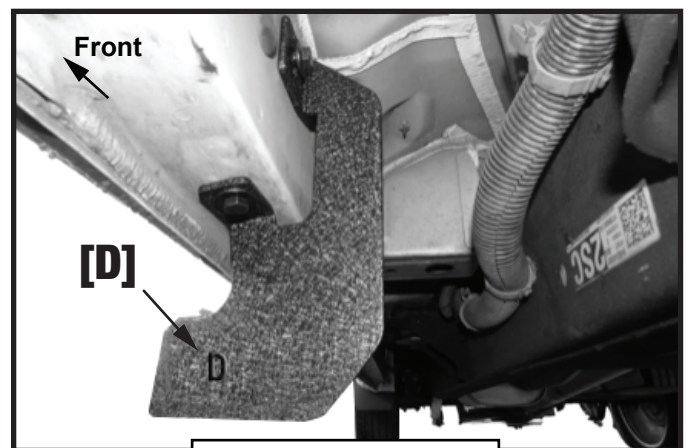

(Fig 4) Installed Bracket [D]

STEP 1 MOUNTING BRACKETS

Follow (Fig 1-13) to attach the brackets to the Passenger Side.

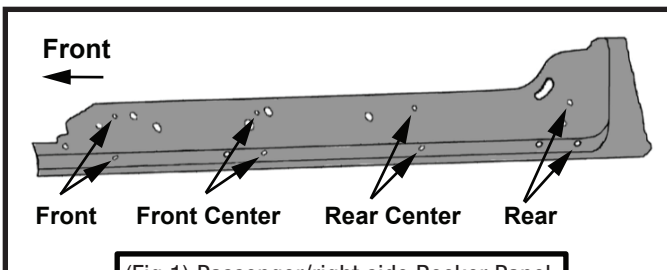
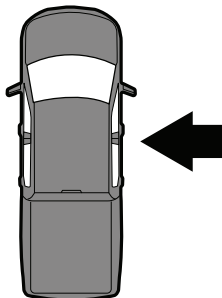

(Fig 1) Passenger/right side Rocker Panel mounting locations illustrated (arrows)

NOTE: Hold Bracket up to body panel to help determine the correct mounting locations

 **Passenger-side Front Mounting Area**

Passenger-side Front Center Mounting Area

Passenger-side Rear Center Mounting Area

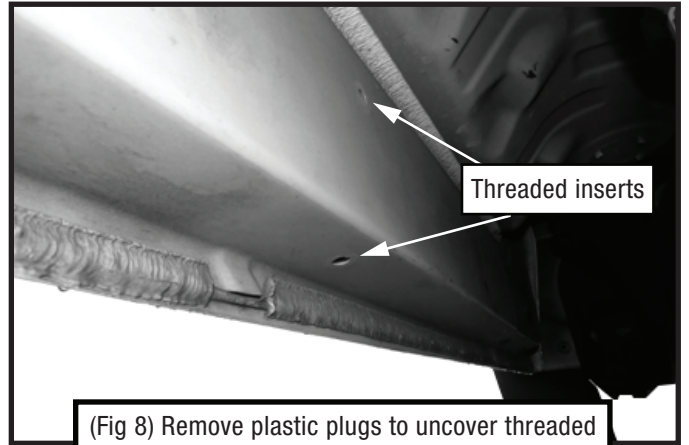
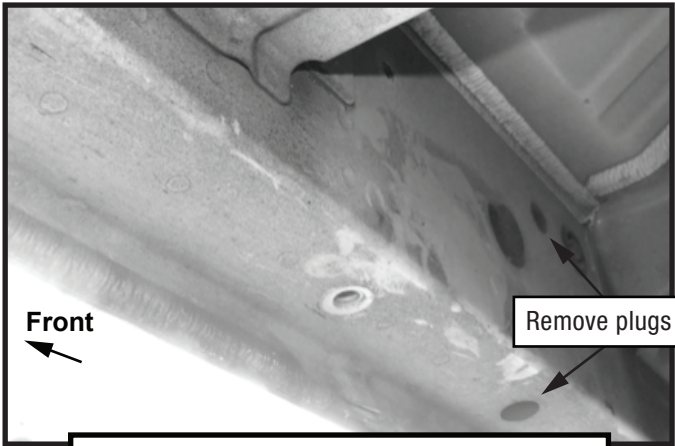

(Fig 5) Remove plastic plugs to uncover threaded inserts for front center mounting location (if any)

(Fig 8) Remove plastic plugs to uncover threaded inserts at rear center mounting location (if any)

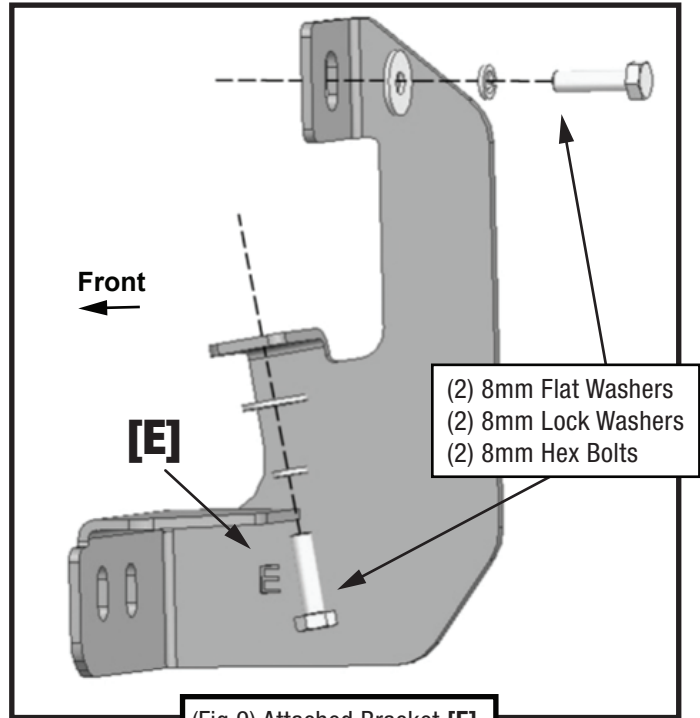
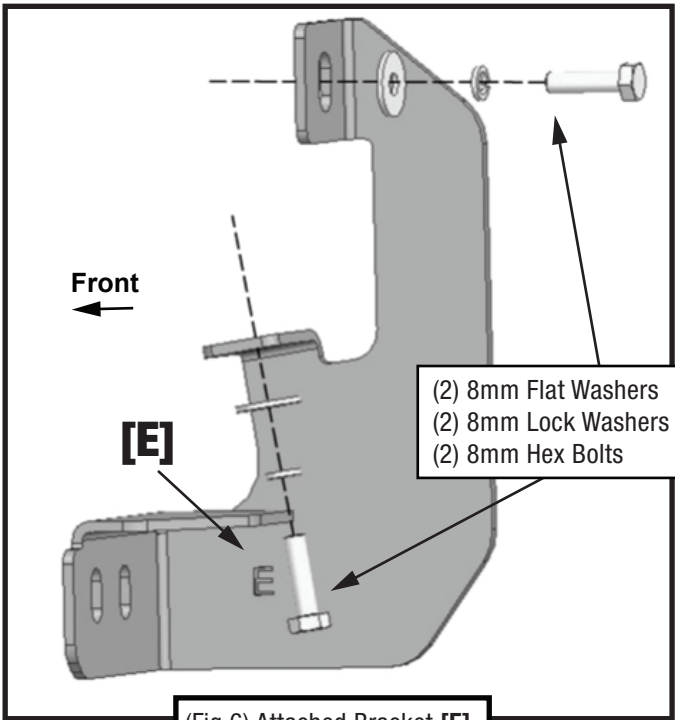

(Fig 6) Attached Bracket [E]

(Fig 9) Attached Bracket [E]

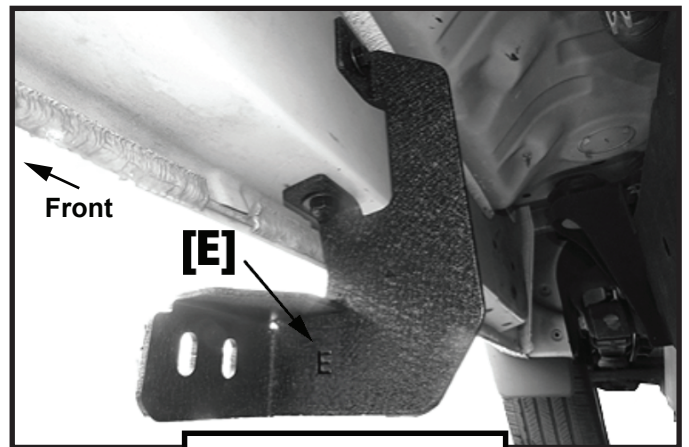

(Fig 7) Installed Bracket [E]

(Fig 10) Installed Bracket [E]

Passenger-side Rear Mounting Area

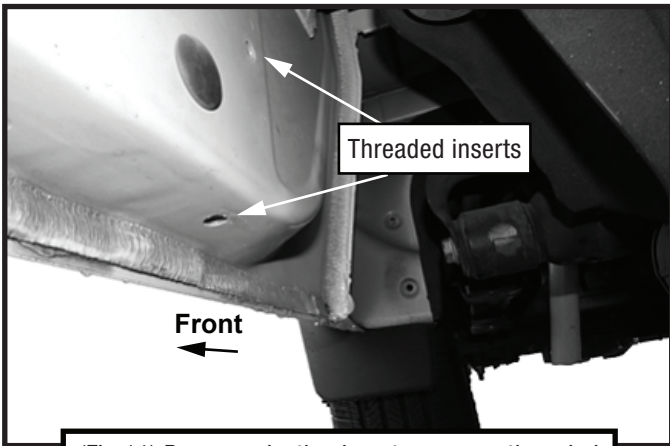

(Fig 11) Remove plastic plugs to uncover threaded inserts at the rear mounting location (if any)

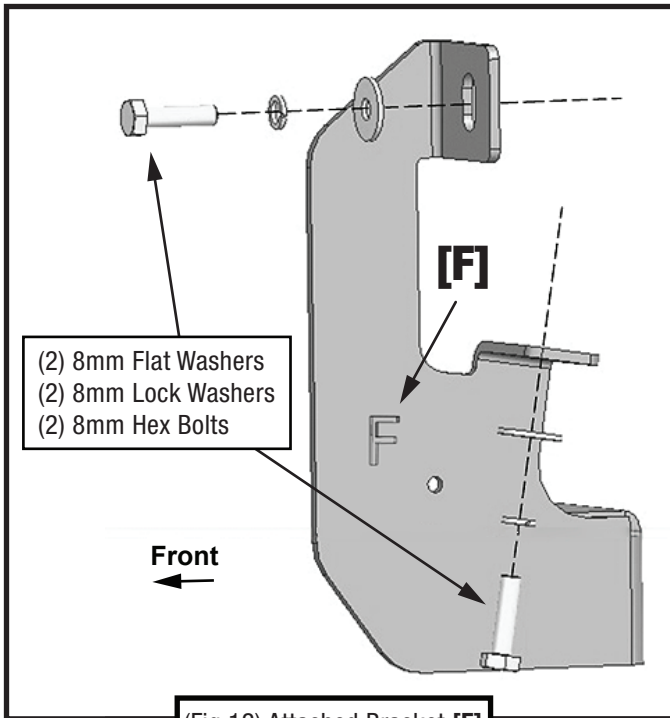

(Fig 12) Attached Bracket [F]

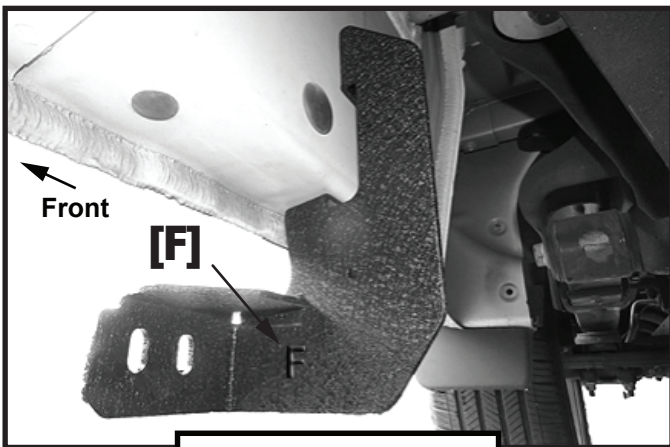

(Fig 13) Installed Bracket [F]

STEP 2 MOUNTING RUNNING BOARDS

Follow (Figs 14-15) to install the driver-side running board.

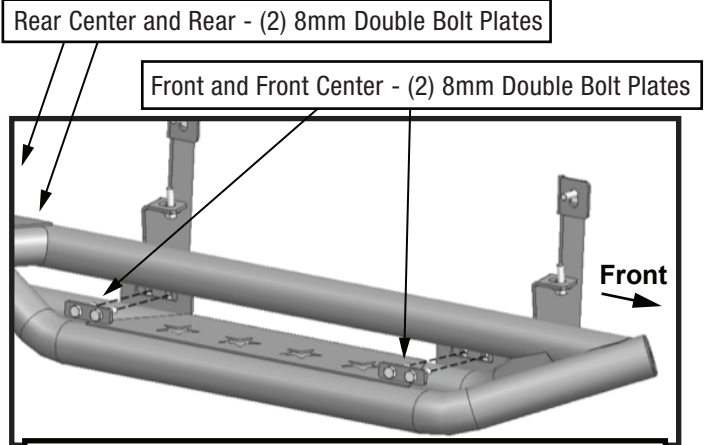

(Fig 14) Insert (4) Double Bolt Plates through running board slots for the Front, Front-Center, Rear-Center, Rear-Center and Rear locations

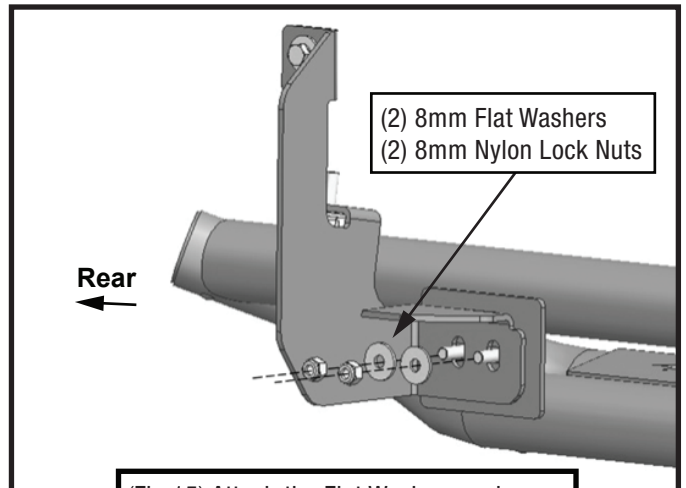

(Fig 15) Attach the Flat Washers and Lock Nuts to the all the Double Bolt Plates

NOTE: Adjust height to your preference

STEP 3 DRIVER SIDE

Repeat **STEPS 1-2** for driver side installation.
 Use Bracket **[A]** instead of **[D]**;
 Use Brackets **[B]** instead of **[E]**;
 Use Bracket **[C]** instead of **[F]**.

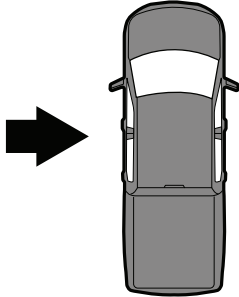

STEP 4

Installation is complete. Do periodic inspections to the installation to make sure that all hardware is secure and tight.



Complete Installation