



## STAR STRIDER®

TG-SR2C74968

### BEFORE INSTALLATION

READ INSTRUCTIONS CAREFULLY BEFORE STARTING INSTALLATION. REMOVE CONTENTS FROM BOX AND VERIFY ALL PARTS ARE PRESENT. FAILURE TO IDENTIFY DAMAGE BEFORE INSTALLATION COULD LEAD TO A REJECTION OF ANY CLAIM. IF MISSING PARTS OR ANY DAMAGE FOUND, PLEASE TAKE A PICTURE FOR THE CLAIM PURPOSE. TO FILE YOUR CLAIM, PLEASE VISIT:

[WWW.TYGERAUTO.COM/CONTACT](http://WWW.TYGERAUTO.COM/CONTACT)

### TORQUE VALUES

Fastener Size	Class 8.8 Torque (ft-lbs)	Class 10.9 Torque (ft-lbs)
6mm	6-7	6-7
8mm	15-16	22-23
10mm	31-32	44-45
12mm	54-55	78-79
14mm	87-88	125-126

- x1 Driver Side Star Strider **[D]**
- x1 Passenger Side Star Strider **[P]**
- x3 Driver Side Front & Central Bracket **[A]**
- x3 Passenger Side Front & Central Bracket **[C]**
- x1 Driver Side Rear Bracket **[B]**
- x1 Passenger Side Rear Bracket **[D]**
- x1 Driver Side Support Bracket **[E]**
- x1 Passenger Side Support Bracket **[F]**
- x8 8-1.25mm x 35mm Double Bolt Plate
- x20 8mm Nylon Lock Nut
- x16 8mm Lock Washer
- x20 8mm x 1.25mm x 30mm Hex Bolt
- x40 8mm x 24mm x 2mm Flat Washer
- x16 8mm Clip Nut

**Parts List**

### Top View

**ATTENTION:** Refer to **[D]** and **[P]** labelling on the side of the tubes to determine Driver and Passenger Star Striders



**Front**

**[P]** Passenger Side Star Strider



**Front**

**[D]** Driver Side Star Strider

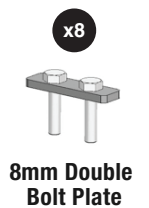
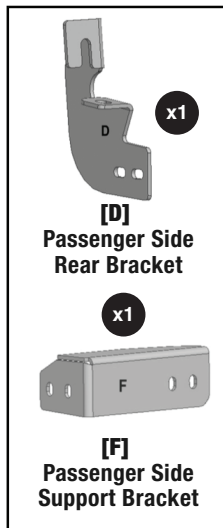
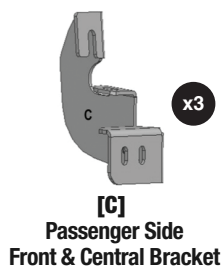
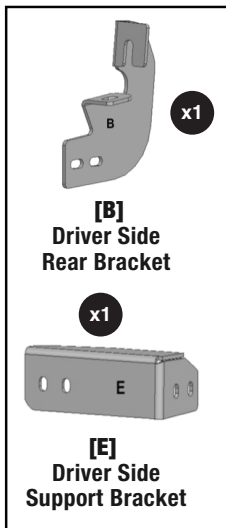
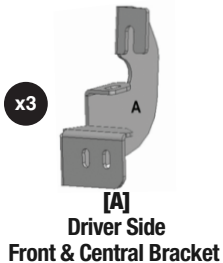

Reference the letters printed on the brackets to determine mounting locations

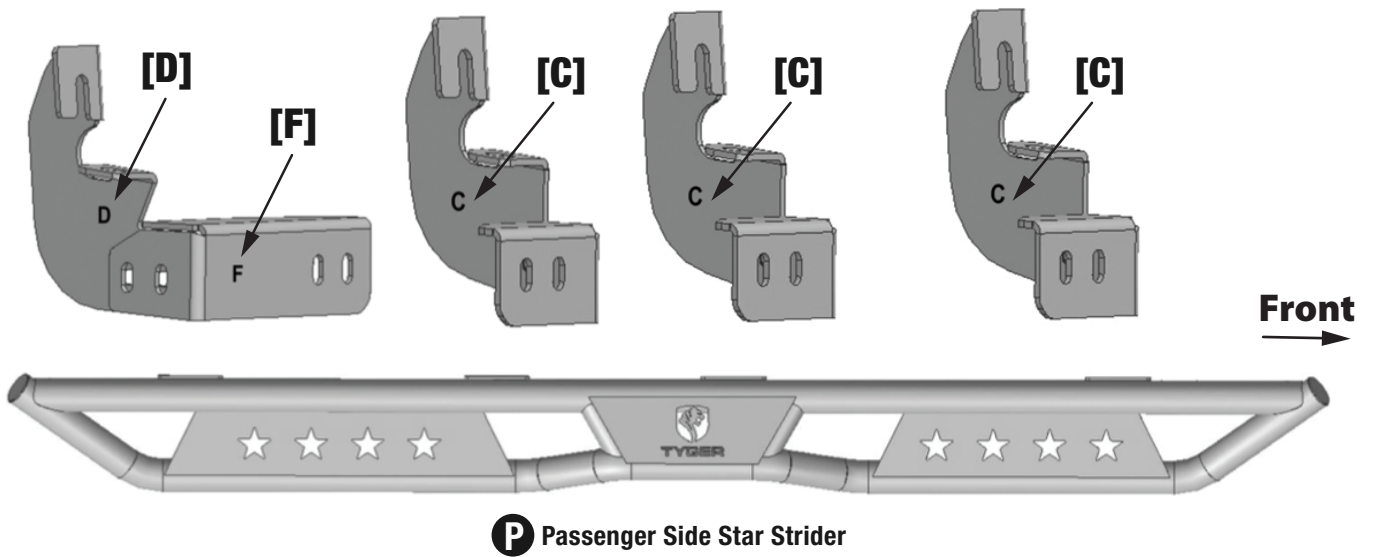
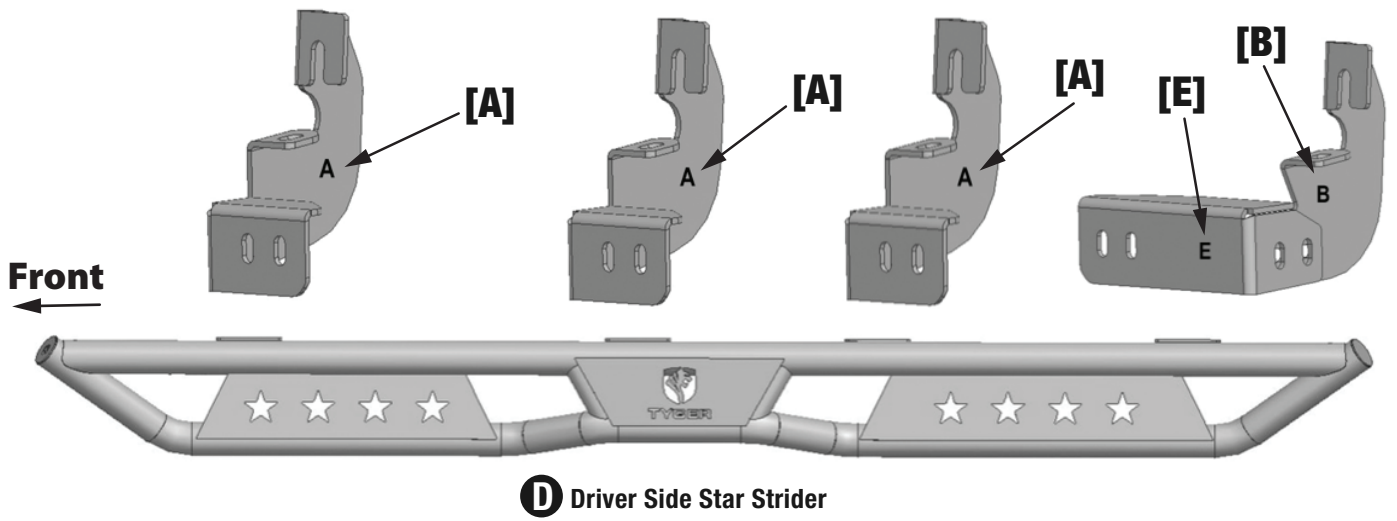

**Bottom View**

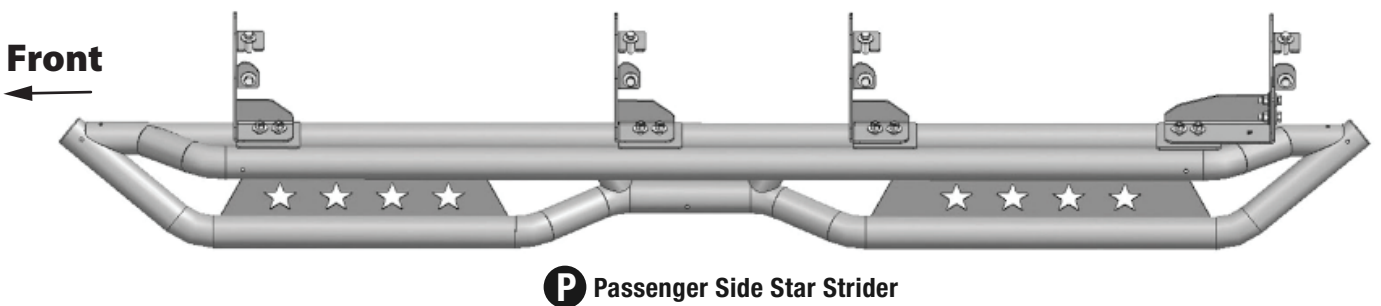
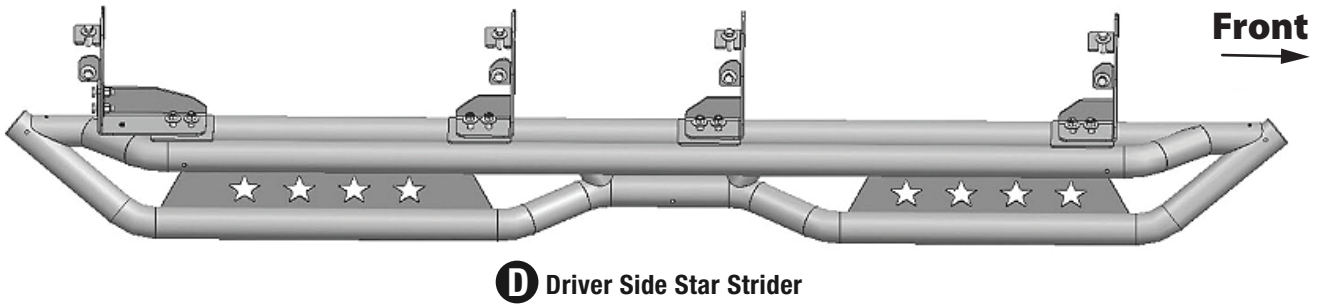

## TOOLS REQUIRED

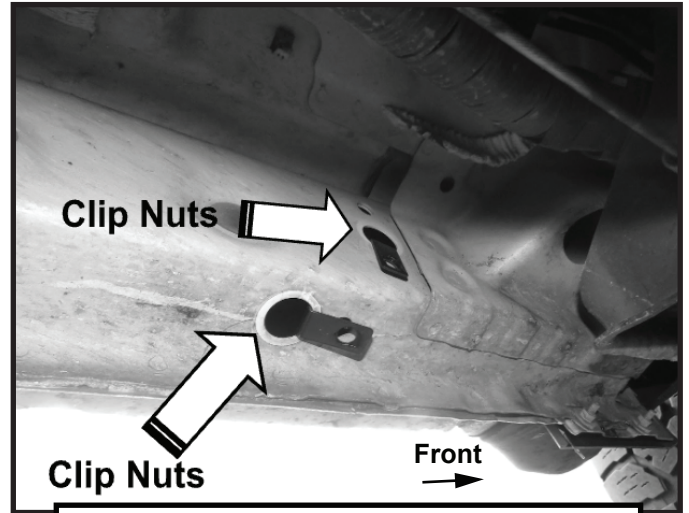
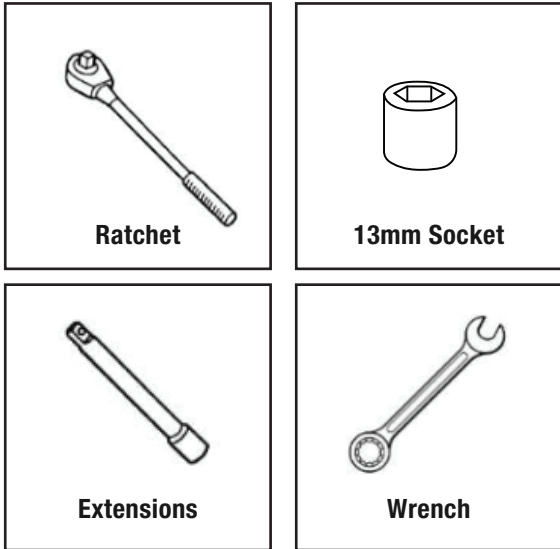

(Fig 2) Installed Clip Nuts and attach Driver Side Front & Center Bracket [A] to front mounting location

## STEP 1 MOUNTING BRACKETS

Follow (Fig 1-13) to attach the brackets to the Driver Side.

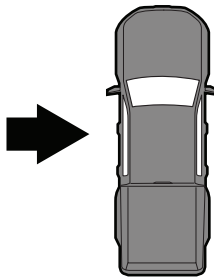

### Driver-side Front Mounting Area

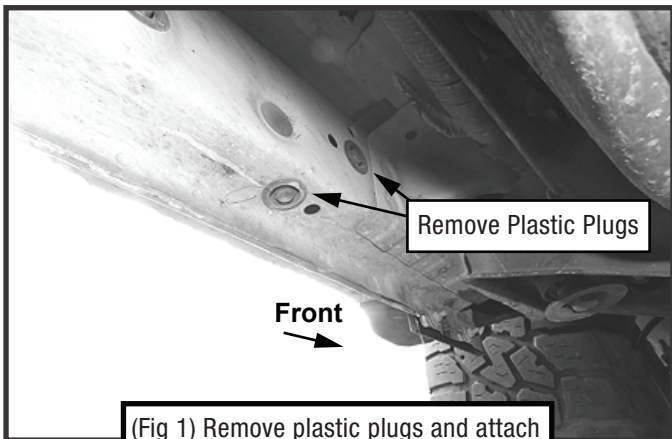

(Fig 1) Remove plastic plugs and attach Clip Nuts to front mounting location

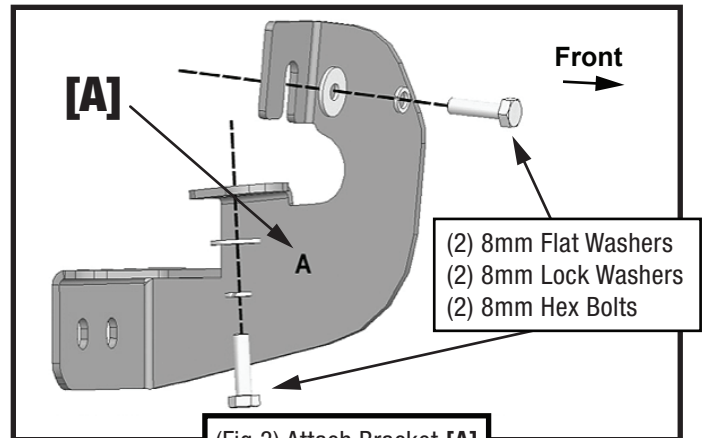

(Fig 3) Attach Bracket [A]

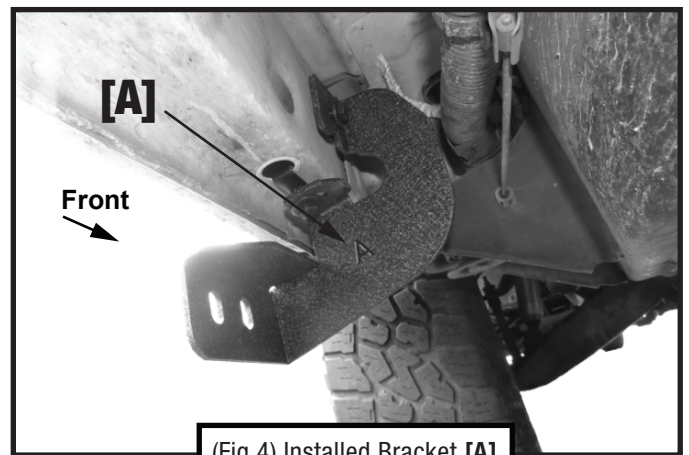

(Fig 4) Installed Bracket [A]

**Driver-side Front-Central Mounting Area**

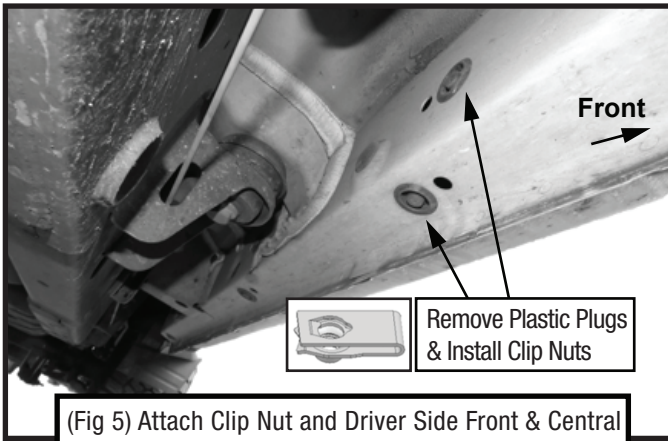

(Fig 5) Attach Clip Nut and Driver Side Front & Central Bracket [A] to front-central mounting location

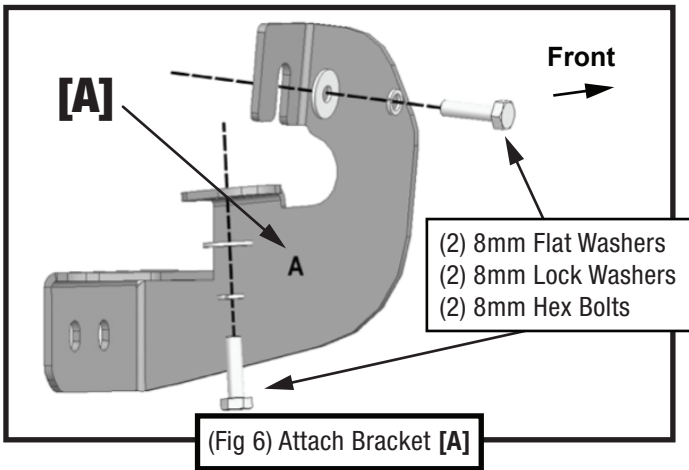

(Fig 6) Attach Bracket [A]

**Driver-side Rear-Central Mounting Area**

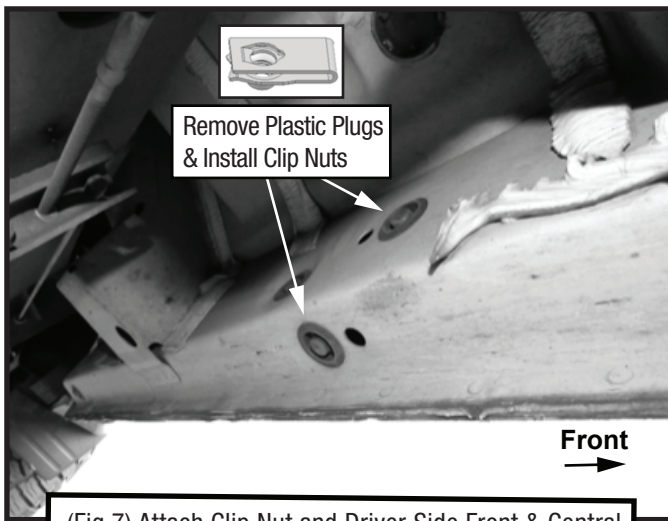

(Fig 7) Attach Clip Nut and Driver Side Front & Central Bracket [A] to rear-central mounting location

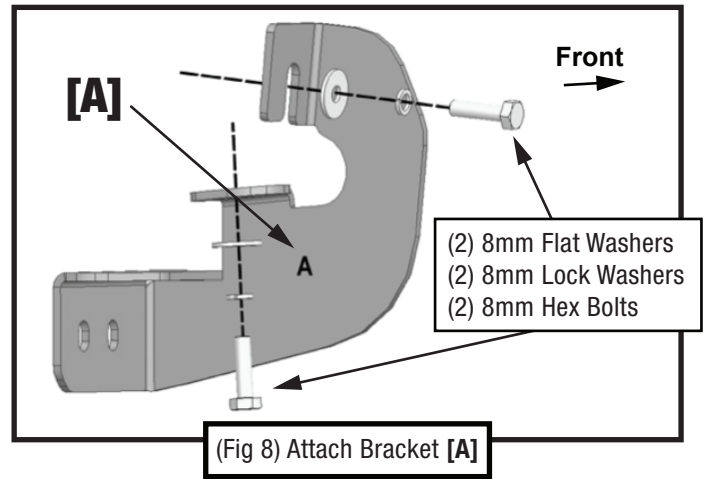

(Fig 8) Attach Bracket [A]

**Driver-side Rear Mounting Area**

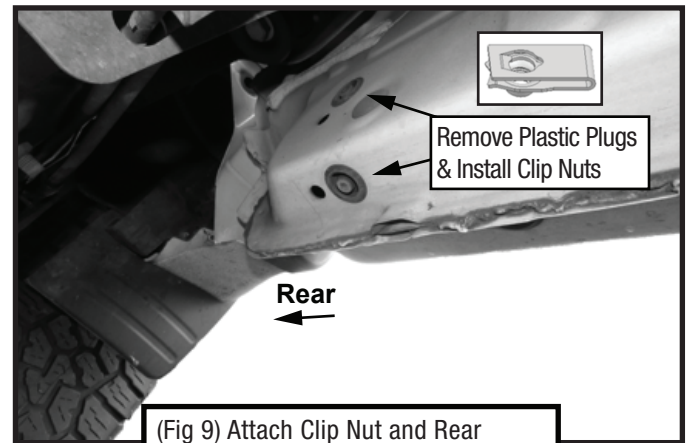

(Fig 9) Attach Clip Nut and Rear Bracket [B] to rear mounting location

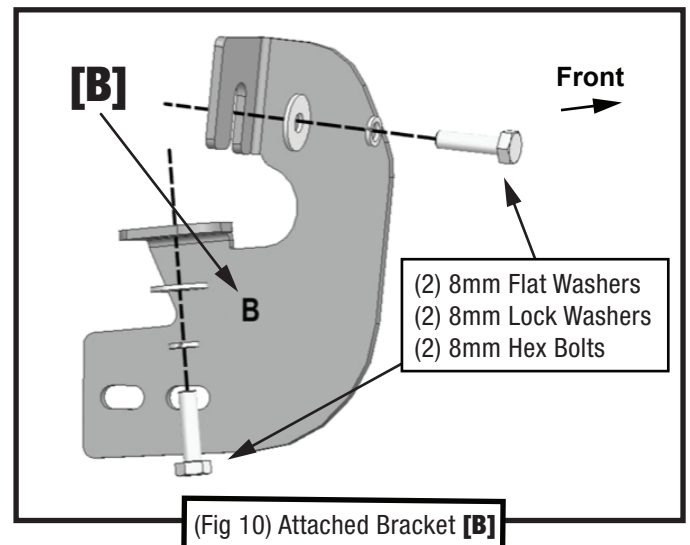

(Fig 10) Attached Bracket [B]



## STEP 2 MOUNTING RUNNING BOARDS

Follow (Figs 14-15) to install the driver-side running board.

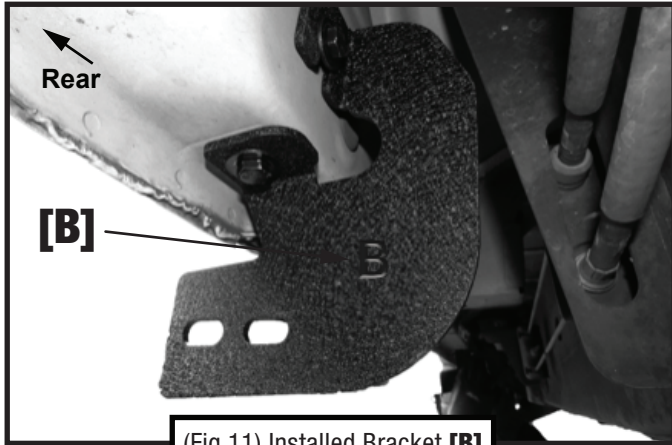

(Fig 11) Installed Bracket [B]

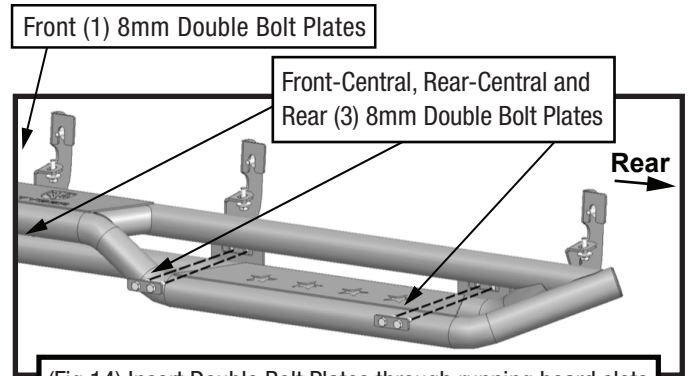

(Fig 14) Insert Double Bolt Plates through running board slots for the **front, front-central, rear-central and rear** locations.

- (2) 8mm Hex Bolts
- (4) 8mm Flat Washers
- (2) 8mm Nylon Lock Nuts

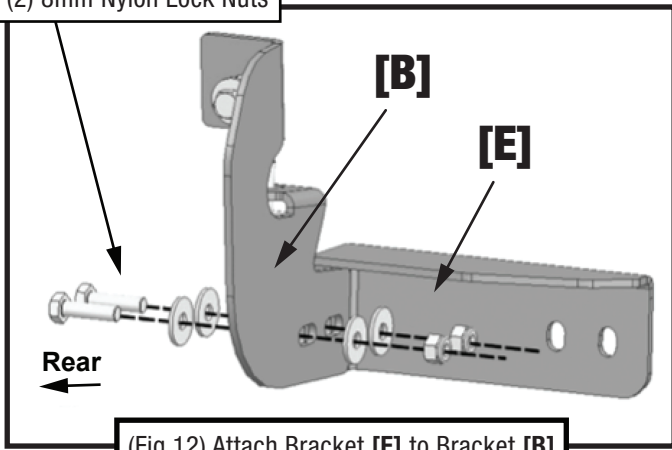

(Fig 12) Attach Bracket [E] to Bracket [B]

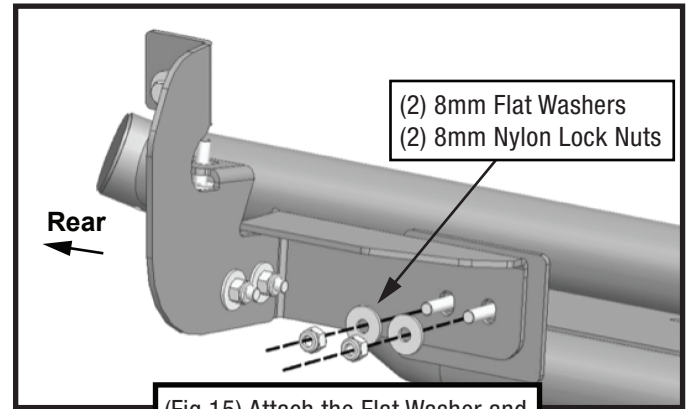

(Fig 15) Attach the Flat Washer and Lock Nut to the Double Bolt Plate

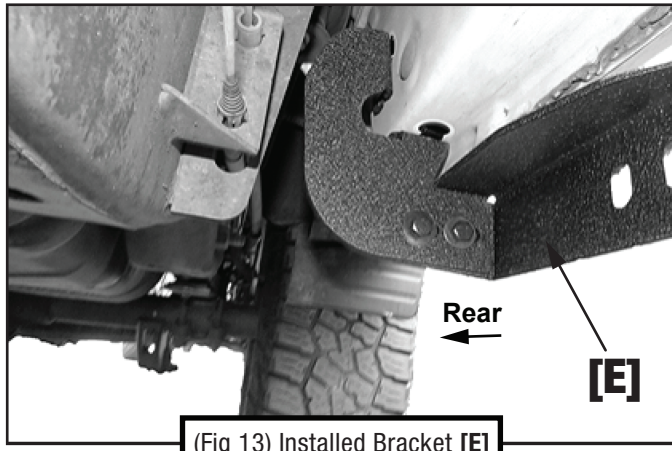

(Fig 13) Installed Bracket [E]

### STEP 3 PASSENGER SIDE

Repeat **STEPS 1-2** for passenger side installation.  
 Use Bracket **[C]** instead of **[A]**;  
 Use Bracket **[D]** instead of **[B]**;  
 Use Bracket **[F]** instead of **[E]**.

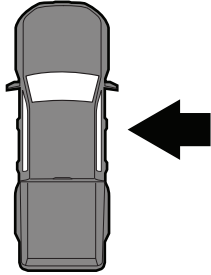

### STEP 4

Installation is complete. Do periodic inspections to the installation to make sure that all hardware is secure and tight.



Complete Installation