



STAR STRIDER®

TG-SR2D74948

Scan to Download the Latest Digital Version



BEFORE INSTALLATION

READ INSTRUCTIONS CAREFULLY BEFORE STARTING INSTALLATION. REMOVE CONTENTS FROM BOX AND VERIFY ALL PARTS ARE PRESENT. FAILURE TO IDENTIFY DAMAGE BEFORE INSTALLATION COULD LEAD TO A REJECTION OF ANY CLAIM. IF MISSING PARTS OR ANY DAMAGE FOUND, PLEASE TAKE A PICTURE FOR THE CLAIM PURPOSE. TO FILE YOUR CLAIM, PLEASE VISIT:

WWW.TYGERAUTO.COM/CONTACT

TORQUE VALUES

Fastener Size	Class 8.8 Torque (ft-lbs)	Class 10.9 Torque (ft-lbs)
6mm	6-7	6-7
8mm	15-16	22-23
10mm	31-32	44-45
12mm	54-55	78-79
14mm	87-88	125-126

- | | | |
|--|---|-----------------------------------|
| x1 Driver Side Star Strider [D] | x2 Passenger Side Support Brackets [G] | x18 8mm Nylon Lock Nuts |
| x1 Passenger Side Star Strider [P] | x1 Driver Side Support Bracket [F] | x12 6mm Nylon Lock Nuts |
| x2 Driver Side Front/Center Brackets [A] | x1 Passenger Side Support Bracket [H] | x36 8mm x 24mm x 2mm Flat Washers |
| x2 Passenger Side Front/Center Brackets [C] | x6 8mm Bolt Plates | x6 8mm Hex Nuts |
| x1 Driver Side Rear Bracket [B] | x6 Plastic Retainers | x24 6mm x 22mm x 2mm Flat Washers |
| x1 Passenger Side Rear Bracket [D] | x6 8mm Double Bolt Plates | x12 8mm Lock Washers |
| x2 Driver Side Support Brackets [E] | x18 8-1.25mm x 30mm Hex Bolts | x12 6-1.0mm x 25mm Hex Bolts |

Parts List

Top View

ATTENTION: Refer to **[D]** and **[P]** labelling on the side of the tubes to determine Driver and Passenger Star Striders



Front

[P] Passenger Side Star Strider

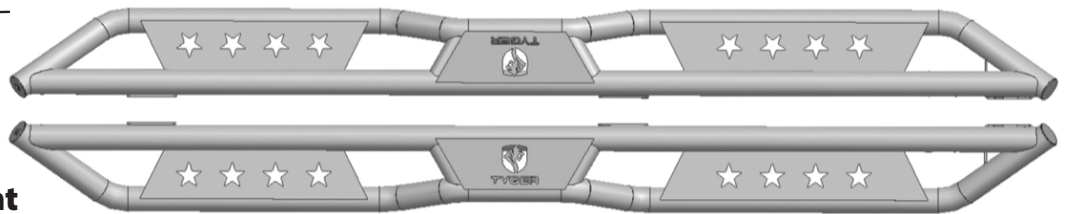

Front

[D] Driver Side Star Strider

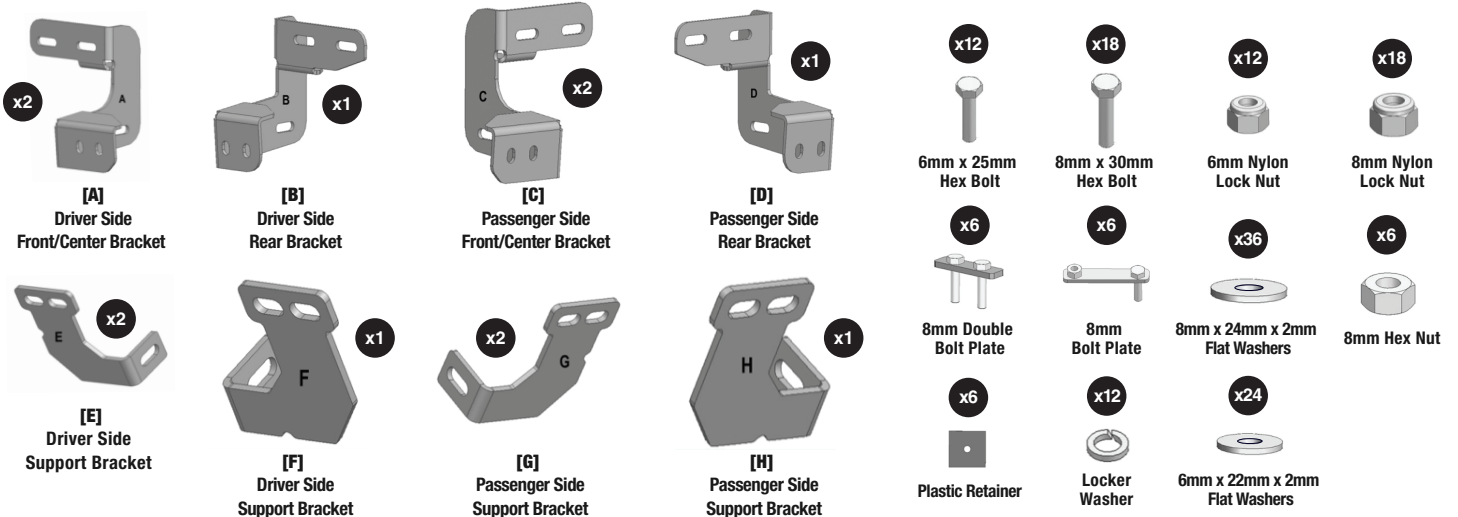

Reference the letters printed on the brackets to determine mounting locations

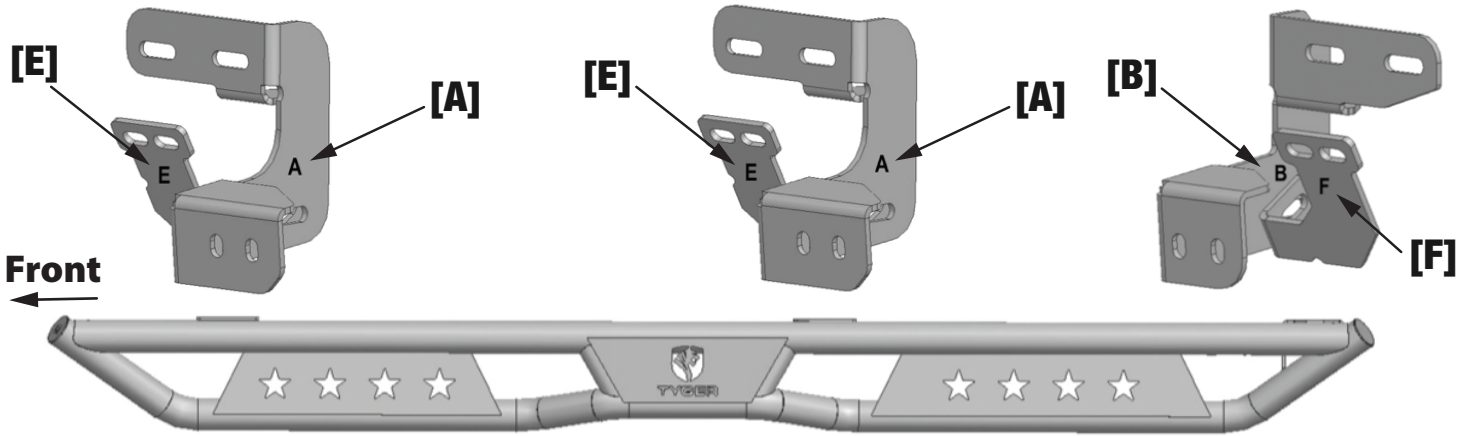

D Driver Side Star Strider

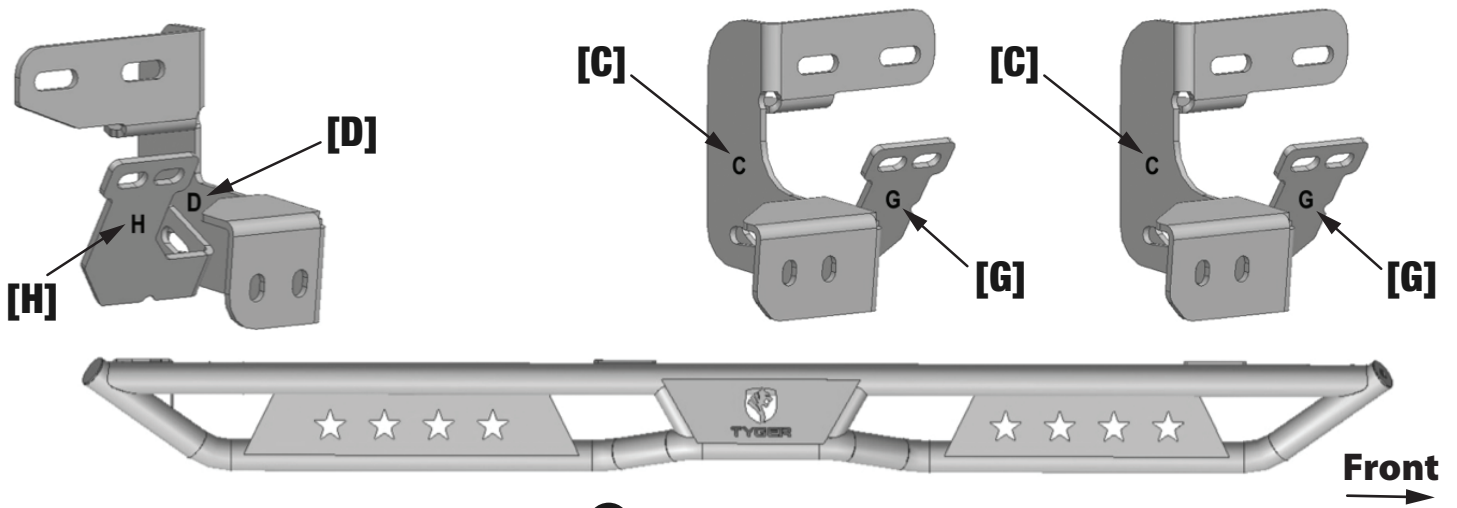

P Passenger Side Star Strider

Bottom View

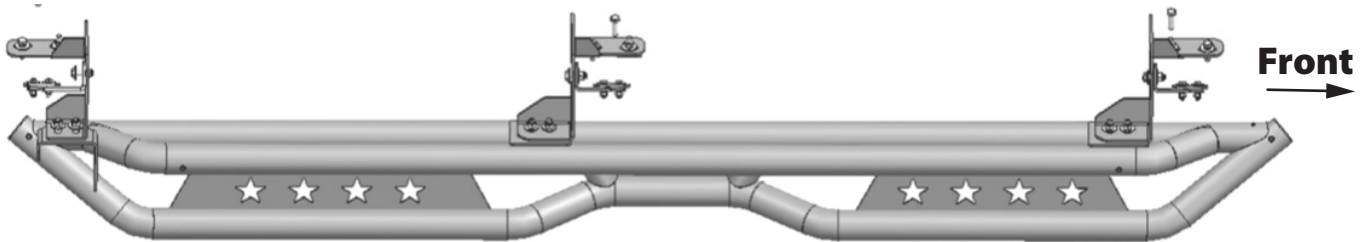

D Driver Side Star Strider

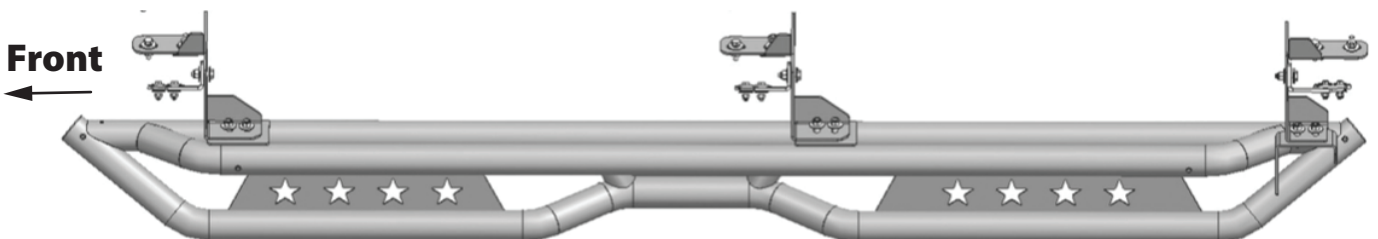

P Passenger Side Star Strider

TOOLS REQUIRED

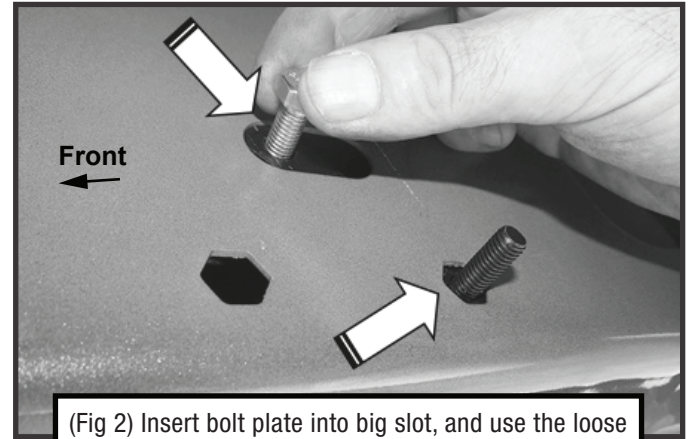
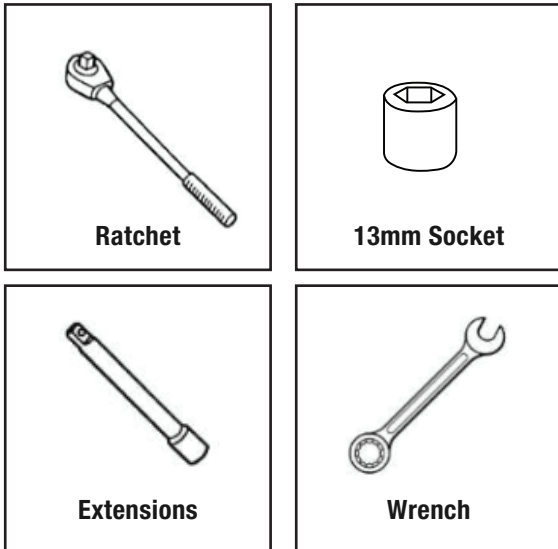

(Fig 2) Insert bolt plate into big slot, and use the loose hex bolt as a handle to feed the threaded end out of the hex shaped hole.

Remove Hex Bolt, rotate Bolt/Nut Plate to line up threaded nut with body panel and Mounting Bracket

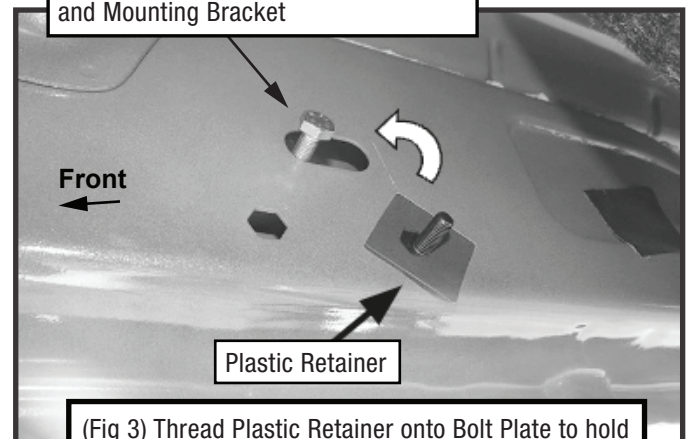

(Fig 3) Thread Plastic Retainer onto Bolt Plate to hold Bolt Plate in position. Hex bolt can be removed to position nut to other hex shaped hole

STEP 1 MOUNTING BRACKETS

Follow (Fig 1-19) to attach the brackets to the Passenger Side.

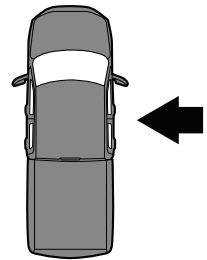

Passenger-side Front Mounting Area

Models without threaded inserts:

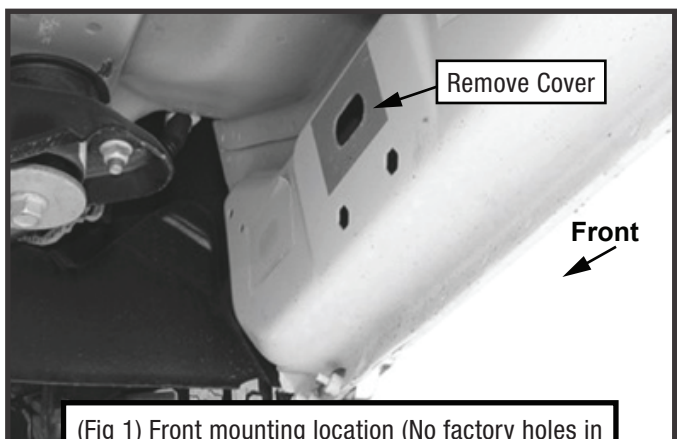

(Fig 1) Front mounting location (No factory holes in pinch weld **2009-2012 models**)

- (1) 8mm Bolt Plate
- (1) Plastic Retainer
- (2) 8mm Flat Washers
- (2) 8mm Lock Washers
- (1) 8mm Hex Nut
- (1) 8mm Hex Bolt

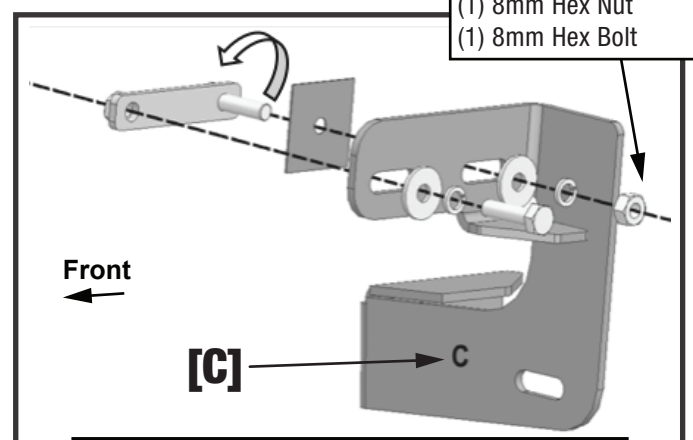

(Fig 4) Rotate Bolt Plate to line up with remaining hex shaped hole, and attach PS Front Bracket with a Hex Bolt through the nut on Bolt Plate **[C]**

Models with threaded inserts:

IMPORTANT: Rust or dirt may build up overtime and clog up the holes preventing the bolts to be installed. In this case, use a 8-1.25mm Tap (not included) to clear and cut new threads to allow the bolts to be mounted.

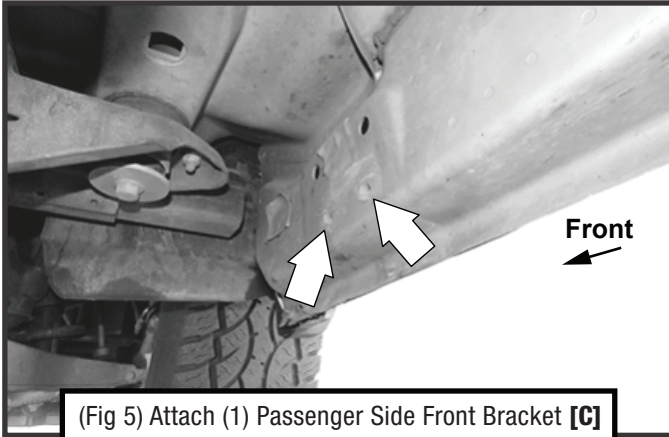

(Fig 5) Attach (1) Passenger Side Front Bracket [C] to the threaded inserts

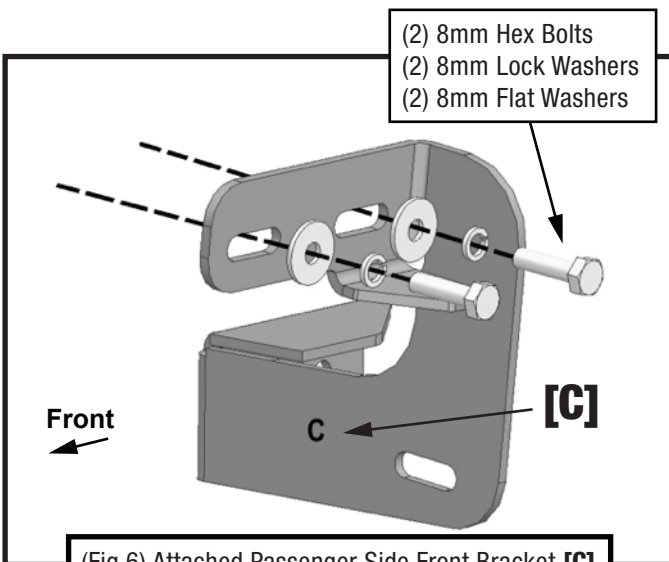

(Fig 6) Attached Passenger Side Front Bracket [C]

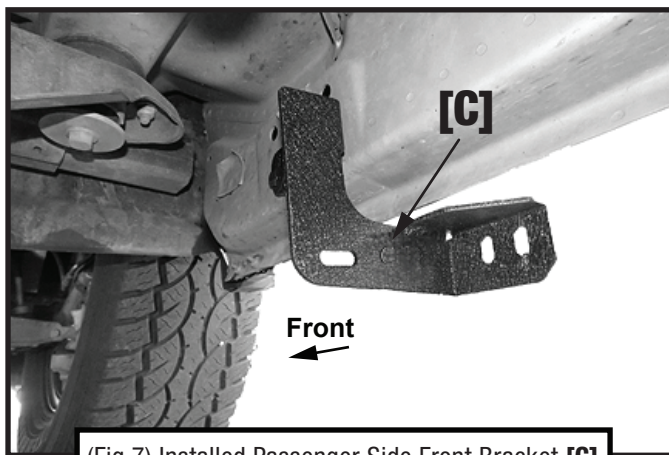

(Fig 7) Installed Passenger Side Front Bracket [C]

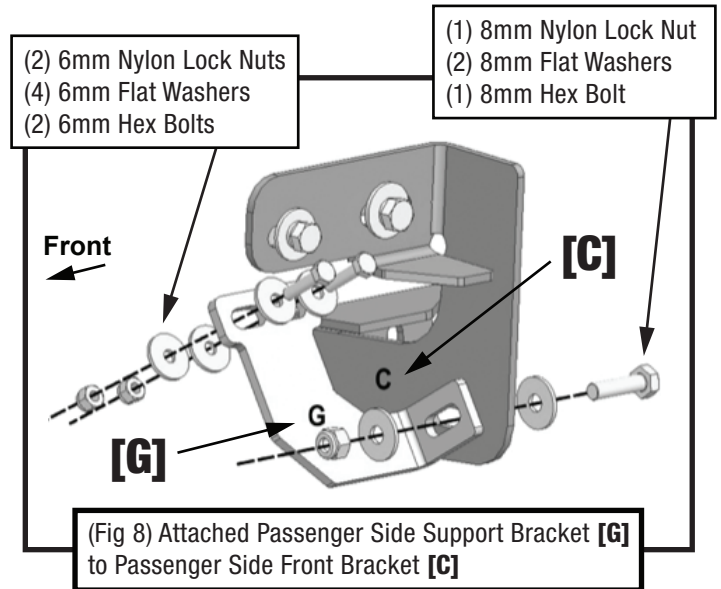

(Fig 8) Attached Passenger Side Support Bracket [G] to Passenger Side Front Bracket [C]

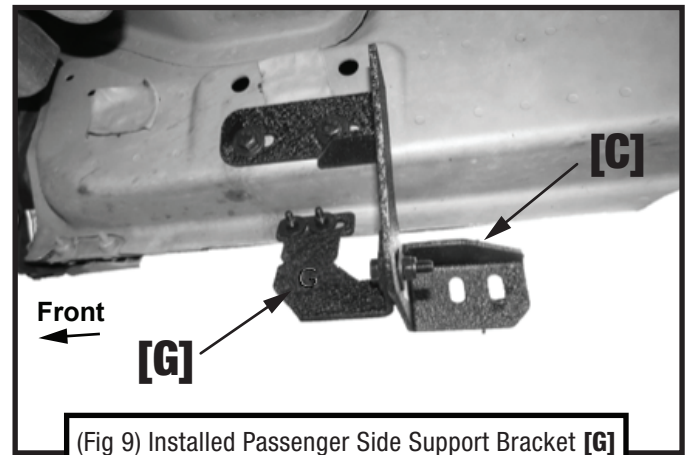

(Fig 9) Installed Passenger Side Support Bracket [G] to Passenger Side Front Bracket [C]

Passenger-side Center Mounting Area

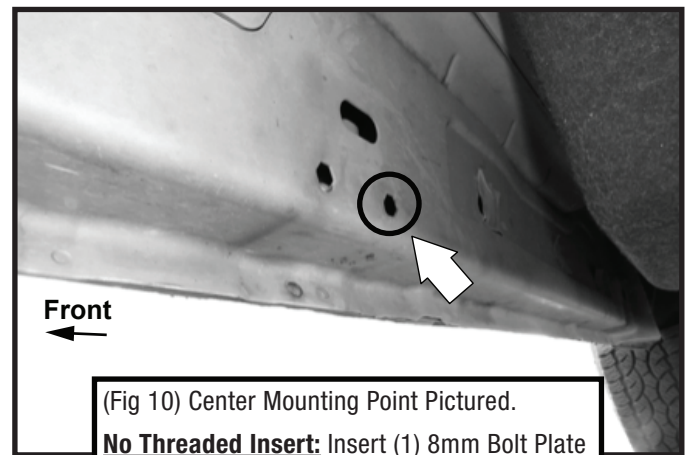

(Fig 10) Center Mounting Point Pictured.
No Threaded Insert: Insert (1) 8mm Bolt Plate as shown in (Fig 3-4) and follow (Fig 11A)
With Threaded Insert: Follow (Fig 11B)

- (1) 8mm Bolt Plate (2) 8mm Lock Washers
- (1) Plastic Retainer (1) 8mm Hex Nut
- (2) 8mm Flat Washers (1) 8mm Hex Bolt

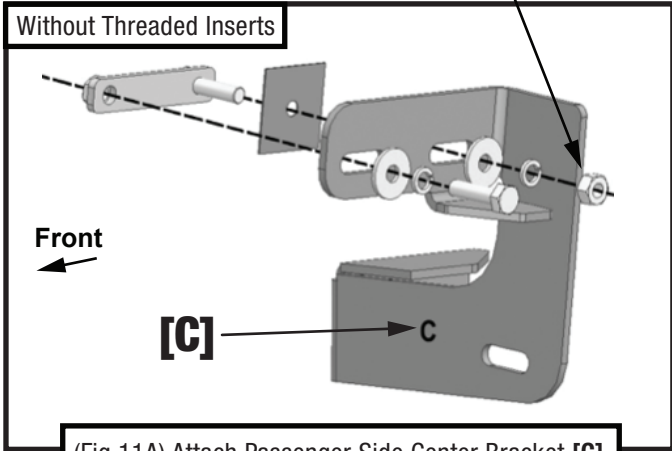

(Fig 11A) Attach Passenger Side Center Bracket [C]

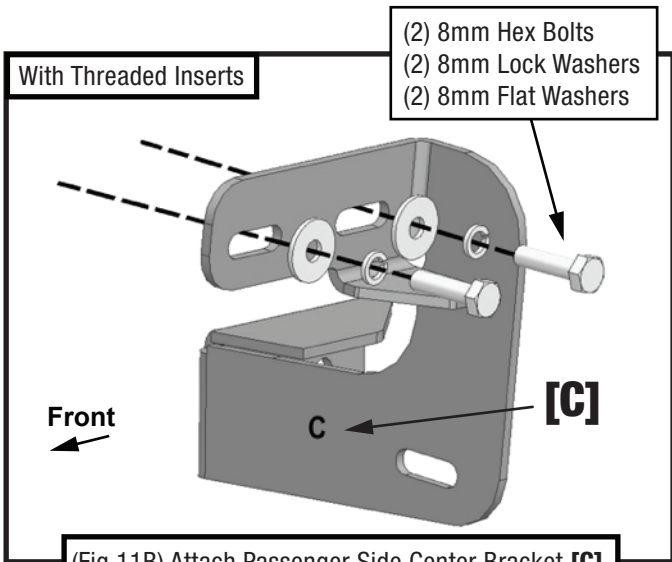

(Fig 11B) Attach Passenger Side Center Bracket [C]

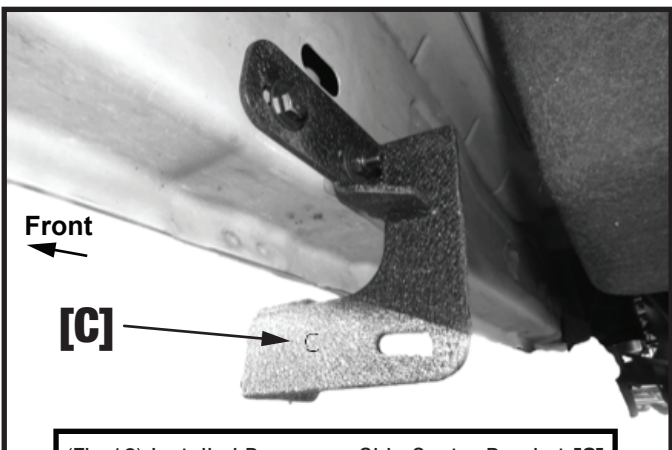

(Fig 12) Installed Passenger Side Center Bracket [C]

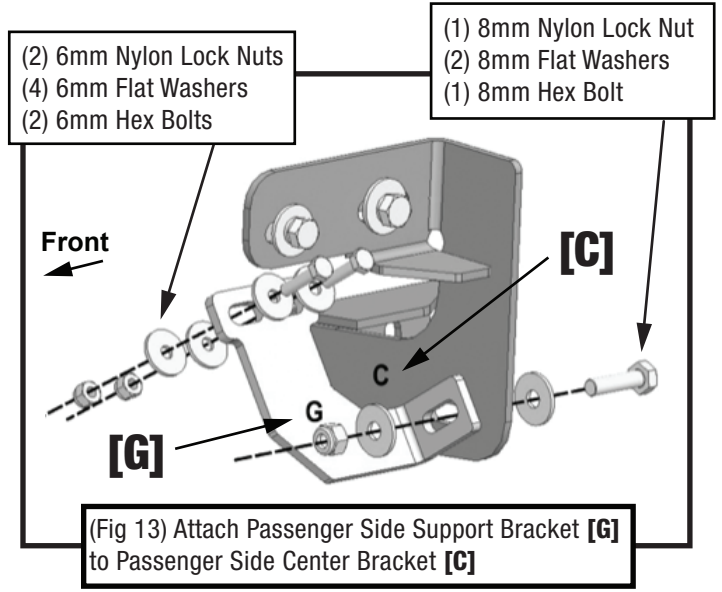

(Fig 13) Attach Passenger Side Support Bracket [G] to Passenger Side Center Bracket [C]

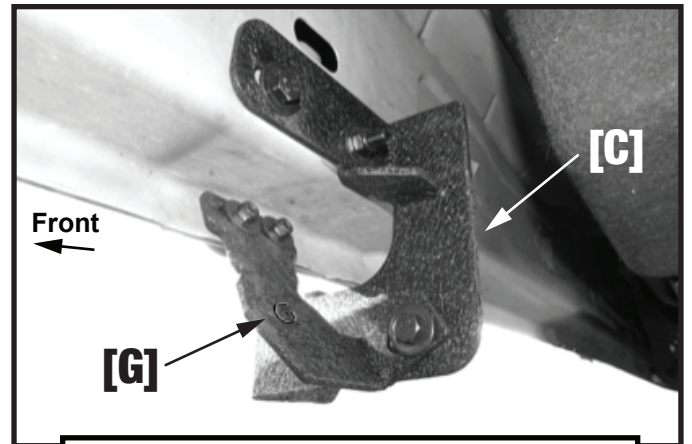

(Fig 14) Installed Passenger Side Support Bracket [G] to Passenger Side Center Bracket [C]

Passenger-side Rear Mounting Area

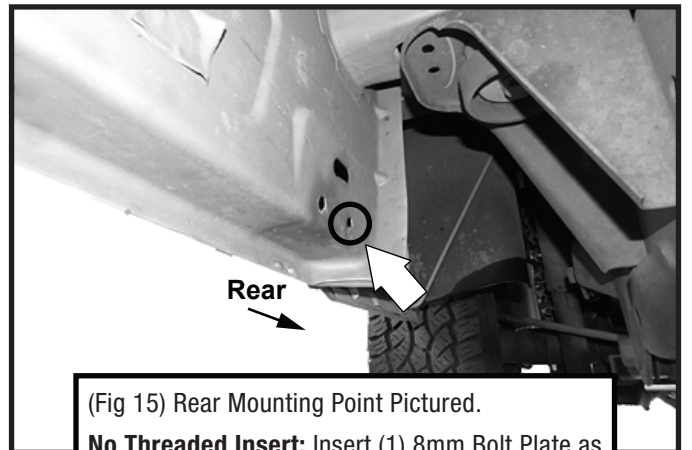

(Fig 15) Rear Mounting Point Pictured.
No Threaded Insert: Insert (1) 8mm Bolt Plate as shown in (Fig 3-4) and follow (Fig 16A)
With Threaded Insert: Follow (Fig 16B)

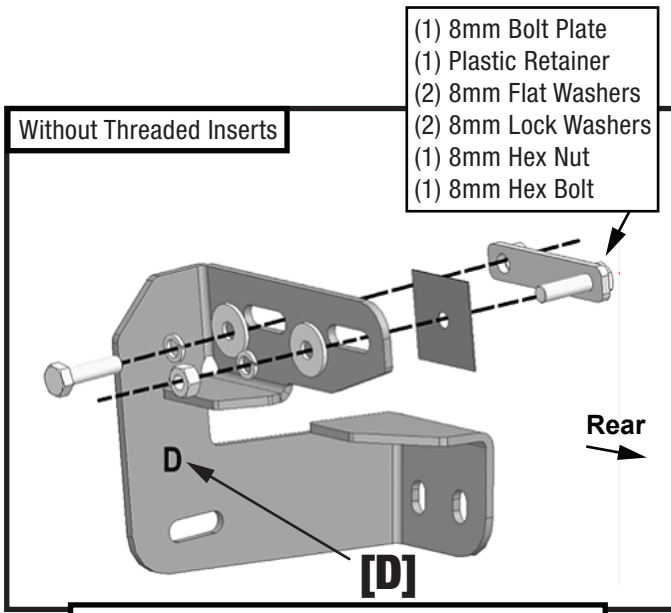

(Fig 16A) Attach Passenger Side Rear Bracket [D]

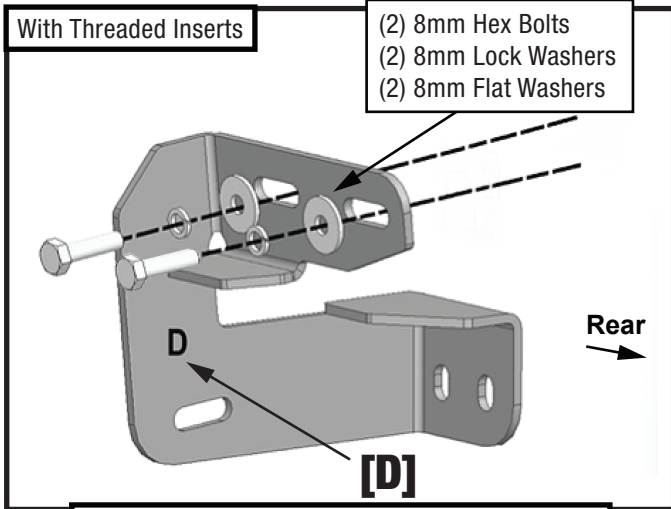

(Fig 16B) Attach Passenger Side Rear Bracket [D]

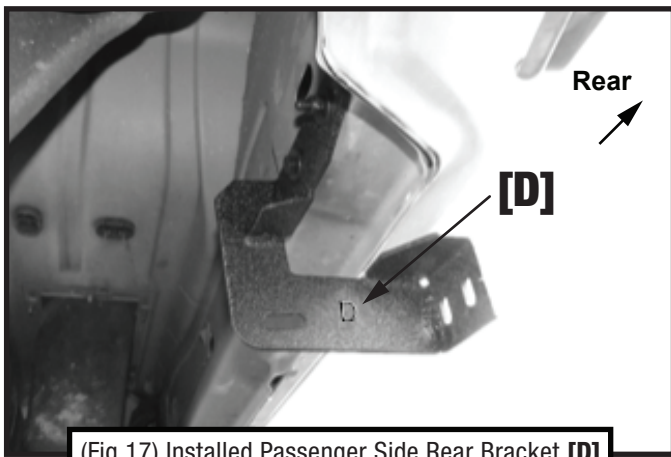

(Fig 17) Installed Passenger Side Rear Bracket [D]

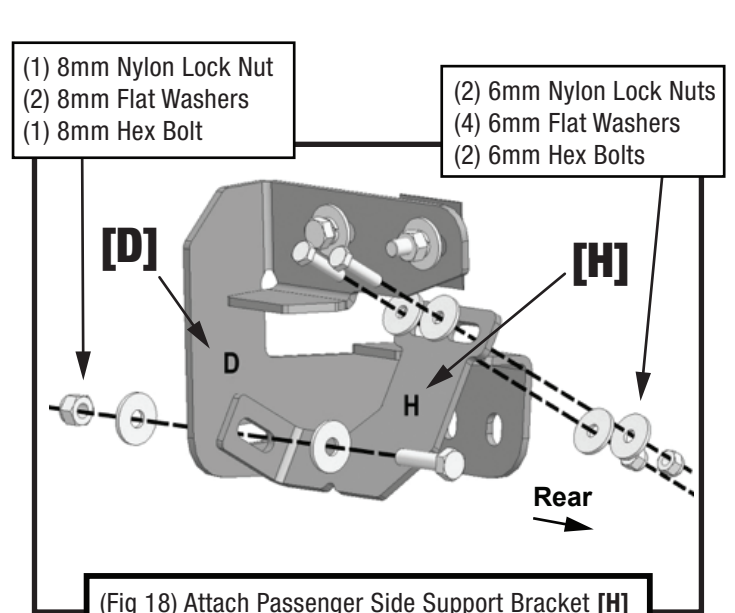

(Fig 18) Attach Passenger Side Support Bracket [H] to PS Rear Bracket [D]

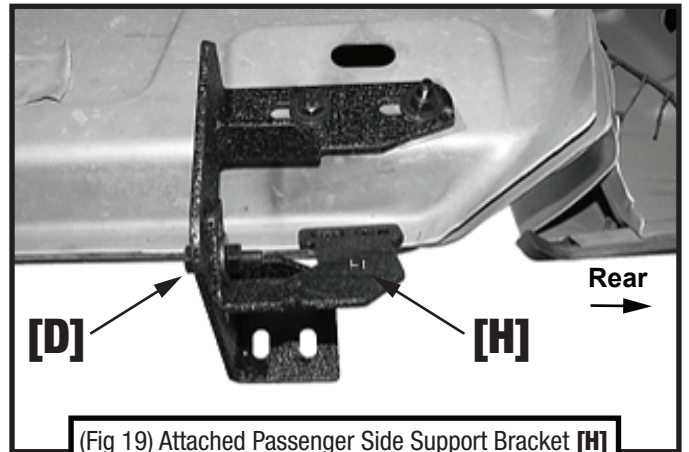

(Fig 19) Attached Passenger Side Support Bracket [H] to Passenger Side Rear Bracket [D]

STEP 2 MOUNTING RUNNING BOARDS

Follow (Figs 20-21) to install the passenger-side running board.

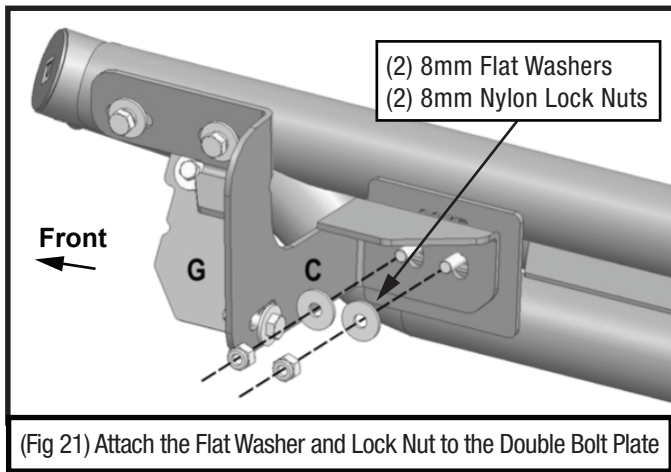
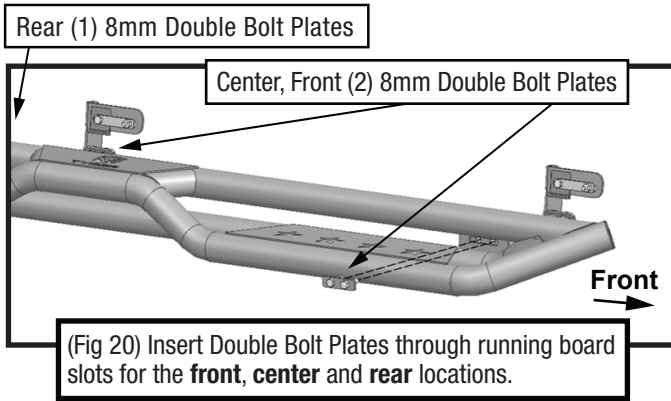

STEP 3 DRIVER SIDE

Repeat **STEPS 1-2** for driver side installation.
 Use Front Bracket **[A]** instead of **[C]**;
 Use Support Bracket **[E]** instead of **[G]**;
 Use Rear Bracket **[B]** instead of **[D]**;
 Use Support Bracket **[F]** instead of **[H]**;

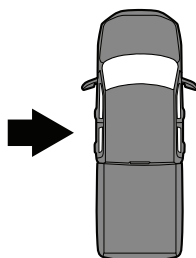

STEP 4

Installation is complete. Do periodic inspections to the installation to make sure that all hardware is secure and tight.

