



STAR STRIDER®

TG-SR2F74998

BEFORE INSTALLATION

READ INSTRUCTIONS CAREFULLY BEFORE STARTING INSTALLATION. REMOVE CONTENTS FROM BOX AND VERIFY ALL PARTS ARE PRESENT. FAILURE TO IDENTIFY DAMAGE BEFORE INSTALLATION COULD LEAD TO A REJECTION OF ANY CLAIM. IF MISSING PARTS OR ANY DAMAGE FOUND, PLEASE TAKE A PICTURE FOR THE CLAIM PURPOSE. TO FILE YOUR CLAIM, PLEASE VISIT:

WWW.TYGERAUTO.COM/CONTACT

TORQUE VALUES

Fastener Size	Class 8.8 Torque (ft-lbs)	Class 10.9 Torque (ft-lbs)
6mm	6-7	6-7
8mm	15-16	22-23
10mm	31-32	44-45
12mm	54-55	78-79
14mm	87-88	125-126

- x1** Driver Side Star Strider **[D]**
- x2** Driver Side Center/Rear Brackets **[B]**
- x36** 8mm x 24mm x 2mm Flat Washers
- x1** Passenger Side Star Strider **[P]**
- x2** Passenger Side Center/Rear Brackets **[E]**
- x36** 8mm Nylon Lock Nuts
- x1** Driver Side Front Bracket **[A]**
- x6** Support Brackets **[D]**
- x18** Plastic Retainers
- x1** Passenger Side Front Bracket **[C]**
- x6** 8mm Double Bolt Plates

Parts List

Top View

ATTENTION: Refer to **[D]** and **[P]** labelling on the side of the tubes to determine Driver and Passenger Star Striders



Front

[P] Passenger Side Star Strider



Front

[D] Driver Side Star Strider

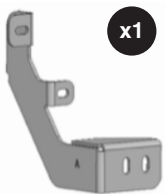

[A]
Driver Side
Front Bracket

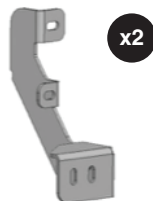

[B]
Driver Side
Center/Rear Bracket

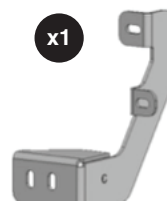

[C]
Passenger Side
Front Bracket

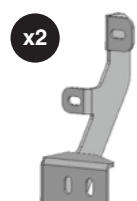

[E]
Passenger Side
Center/Rear Bracket



[D]
Support Bracket



Plastic Retainer



Flat Washer



M8 Nylon Lock Nut

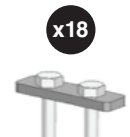

8mm Double Bolt Plate

Reference the letters printed on the brackets to determine mounting locations

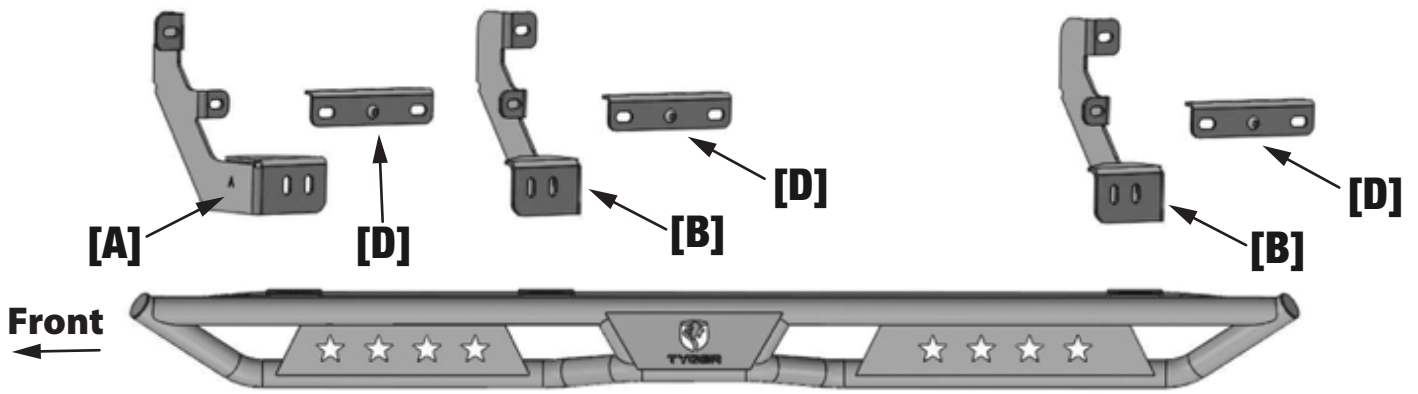

D Driver Side Star Strider

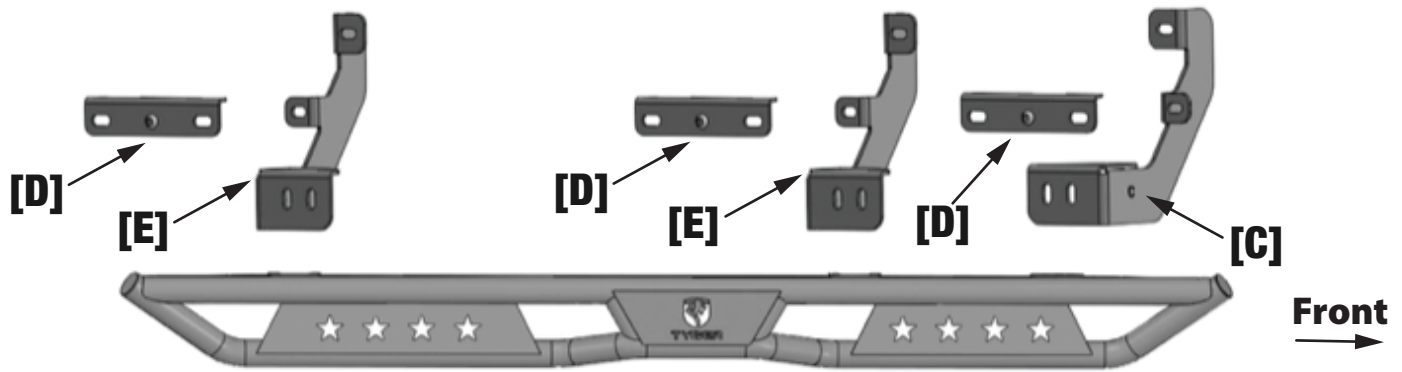

P Passenger Side Star Strider

Bottom View

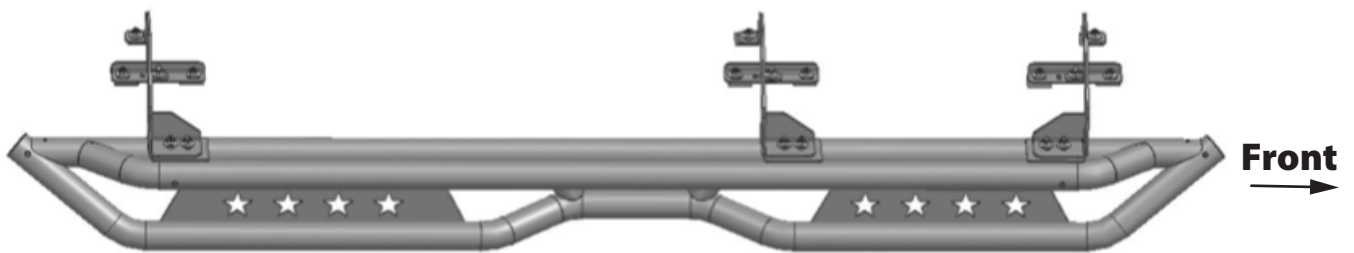

D Driver Side Star Strider

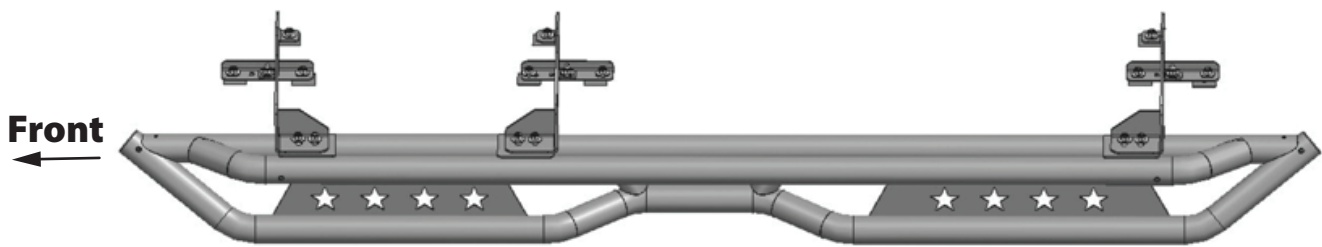

P Passenger Side Star Strider

TOOLS REQUIRED

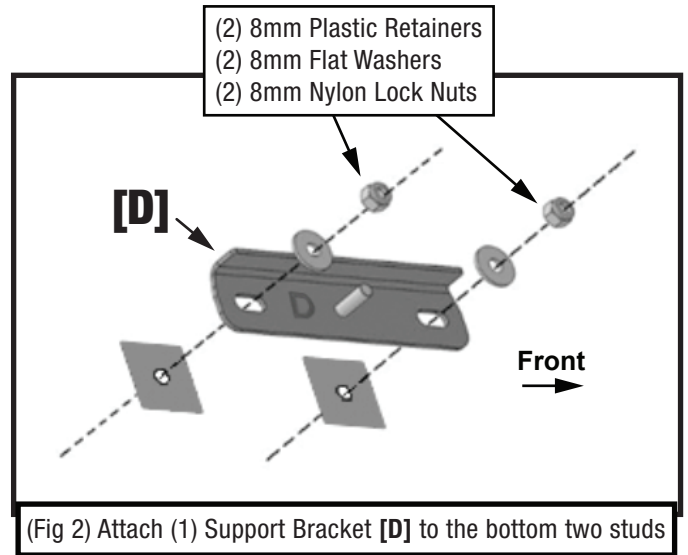
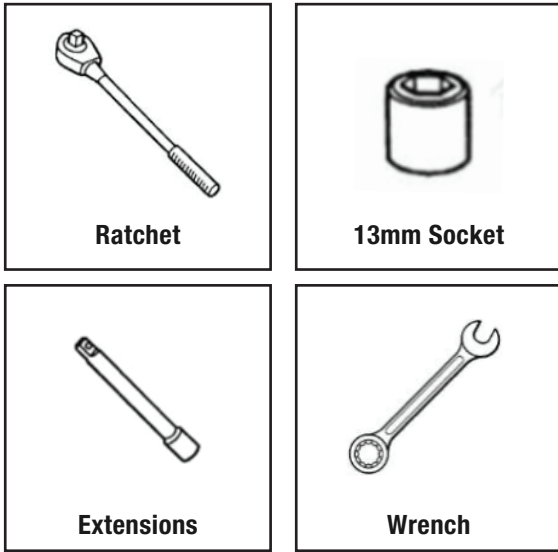

STEP 1 MOUNTING BRACKETS

Follow (Figs 1-8) to attach the 3 sets of mounting brackets to the Driver Side.

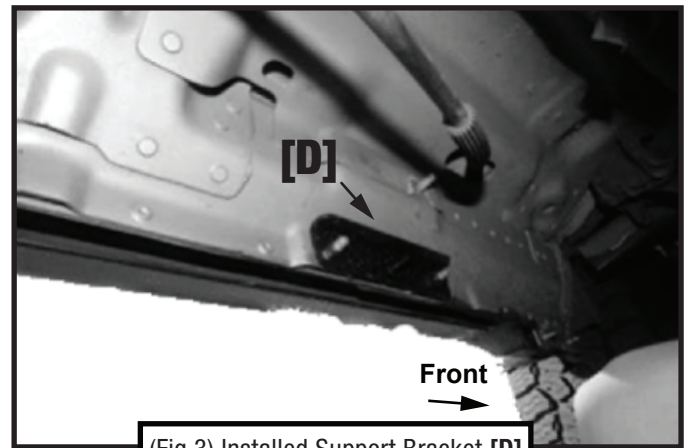
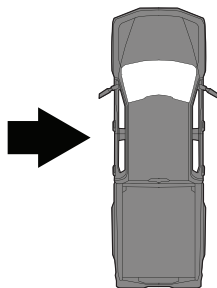

Driver-side Front Mounting Studs

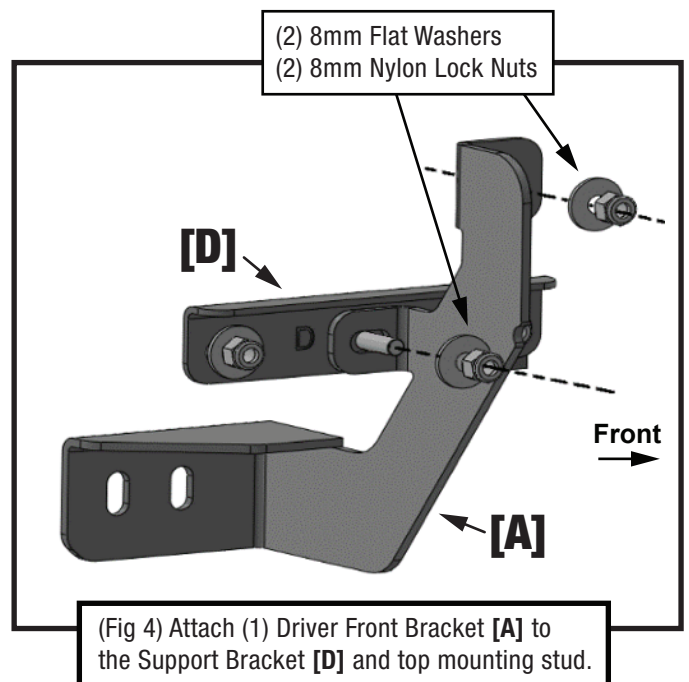
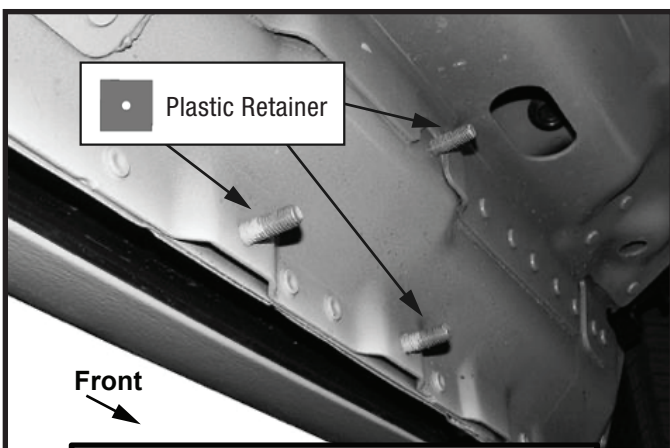

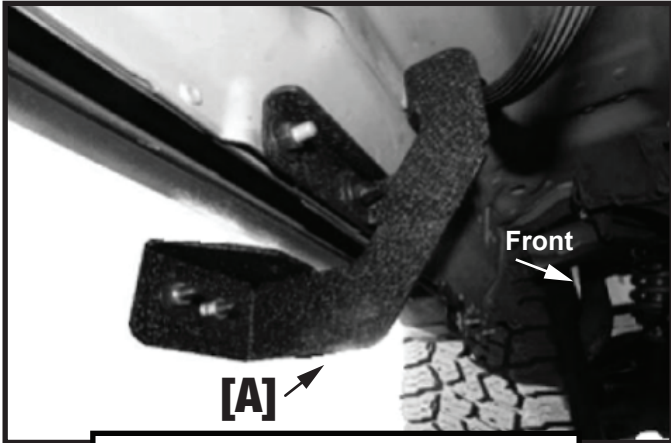

(Fig 5) Installed Driver Side Front Bracket [A]

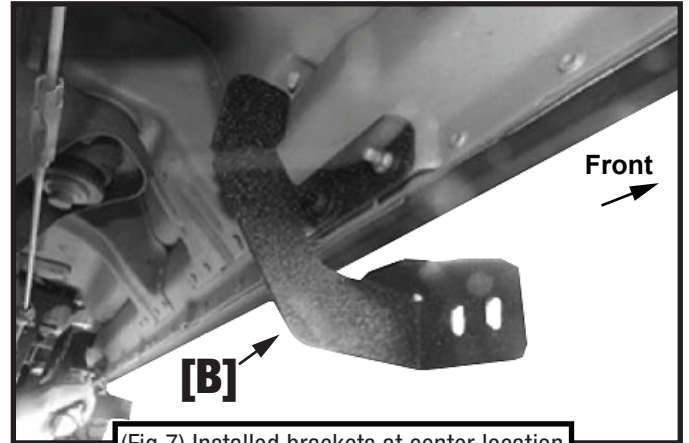

(Fig 7) Installed brackets at center location

Driver-side Center Mounting Studs

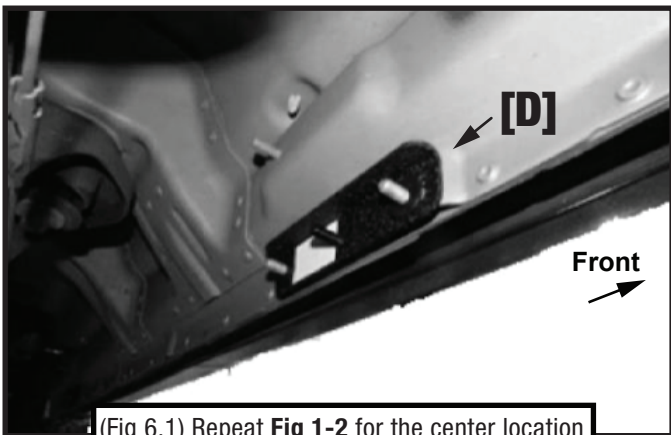

(Fig 6.1) Repeat Fig 1-2 for the center location studs. Use Bracket [B] instead of [A]

Driver-side Rear Mounting Studs

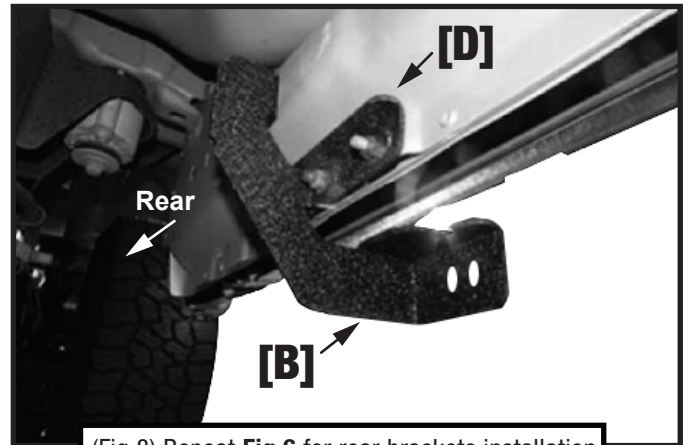

(Fig 8) Repeat Fig 6 for rear brackets installation

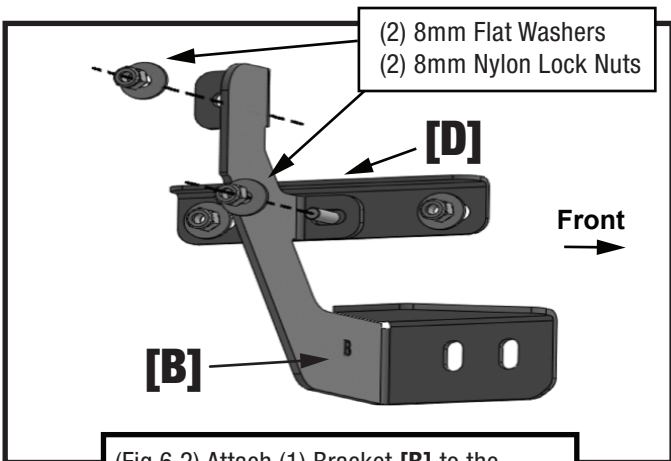

(Fig 6.2) Attach (1) Bracket [B] to the Support Bracket [D] and top mounting stud.

STEP 2 MOUNTING RUNNING BOARDS

Follow (Figs 9-10) to install the driver-side running board.

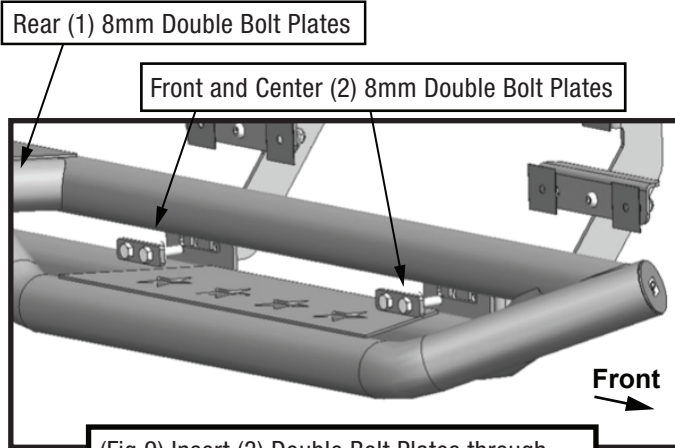

(Fig 9) Insert (3) Double Bolt Plates through running board slots for Front, Center, and Rear

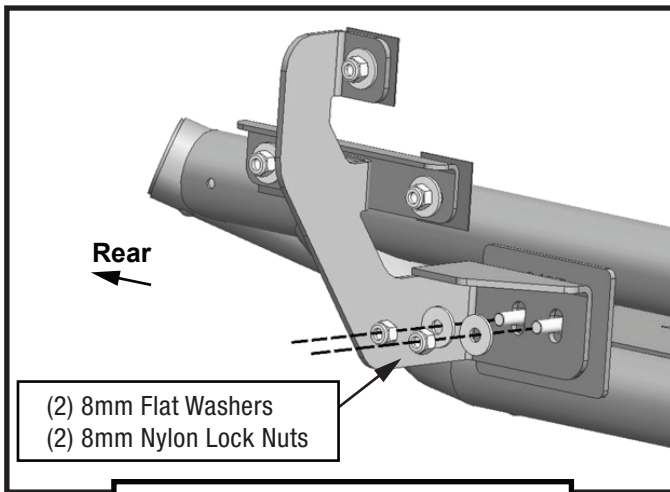

(Fig 10) Attach the Flat Washers and Lock Nuts to the all the Double Bolt Plates

STEP 3 PASSENGER SIDE

Repeat **STEP 1** for passenger side installation.
Use Bracket **[C]** instead of **[A]**;
Use Brackets **[E]** instead of **[B]**;
Support Bracket **[D]** works for both sides.

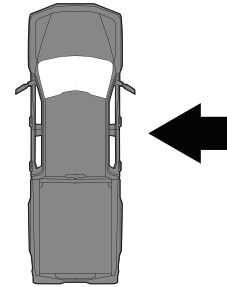

STEP 4

Installation is complete. Do periodic inspections to the installation to make sure that all hardware is secure and tight.



Complete Installation