



# STAR STRIDER®

TG-SR2J74918

## BEFORE INSTALLATION

READ INSTRUCTIONS CAREFULLY BEFORE STARTING INSTALLATION. REMOVE CONTENTS FROM BOX AND VERIFY ALL PARTS ARE PRESENT. FAILURE TO IDENTIFY DAMAGE BEFORE INSTALLATION COULD LEAD TO A REJECTION OF ANY CLAIM. IF MISSING PARTS OR ANY DAMAGE FOUND, PLEASE TAKE A PICTURE FOR THE CLAIM PURPOSE. TO FILE YOUR CLAIM, PLEASE VISIT:

[WWW.TYGERAUTO.COM/CONTACT](http://WWW.TYGERAUTO.COM/CONTACT)

## TORQUE VALUES

Fastener Size	Class 8.8 Torque (ft-lbs)	Class 10.9 Torque (ft-lbs)
6mm	6-7	6-7
8mm	15-16	22-23
10mm	31-32	44-45
12mm	54-55	78-79
14mm	87-88	125-126

- x1** Driver Side Star Strider **[D]**
- x1** Passenger Side Star Strider **[P]**
- x1** Driver Side Front Bracket **[A]**
- x1** Passenger Side Front Bracket **[D]**
- x1** Driver Side Center Bracket **[B]**
- x1** Passenger Side Center Bracket **[E]**
- x1** Driver Side Rear Bracket **[C]**
- x1** Passenger Side Rear Bracket **[F]**
- x6** 8-1.25mm x 35mm Double Bolt Plate
- x12** 8mm x 24mm x 2mm Flat Washers
- x12** 8mm Nylon Lock Nuts
- x6** 8-1.25mm x 35mm Hex Bolts
- x6** 8mm Lock Washers
- x6** 8mm x 28mm x 3mm Flat Washers
- x12** 6-1.0mm x 25mm Hex Bolts
- x24** 6mm x 22mm x 2mm Flat Washers
- x12** 6mm Nylon Lock Nuts

## Parts List

## Top View

**ATTENTION:** Refer to **[D]** and **[P]** labelling on the side of the tubes to determine Driver and Passenger Star Striders

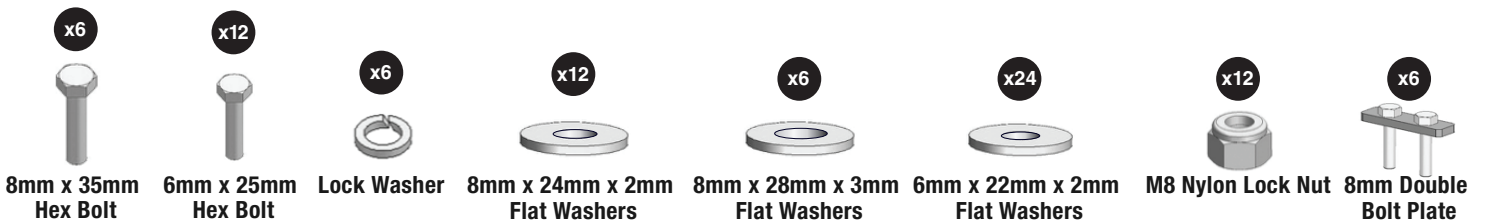
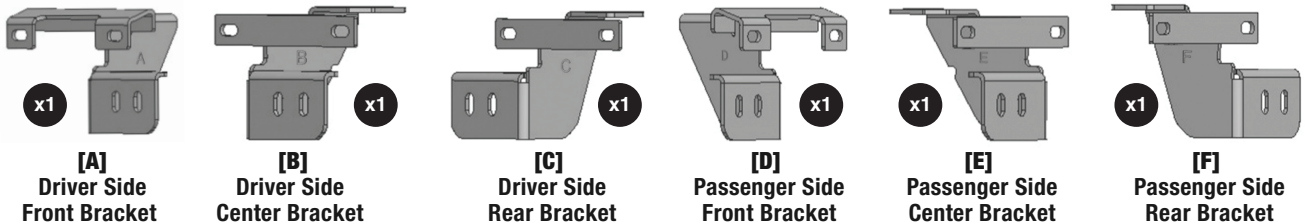
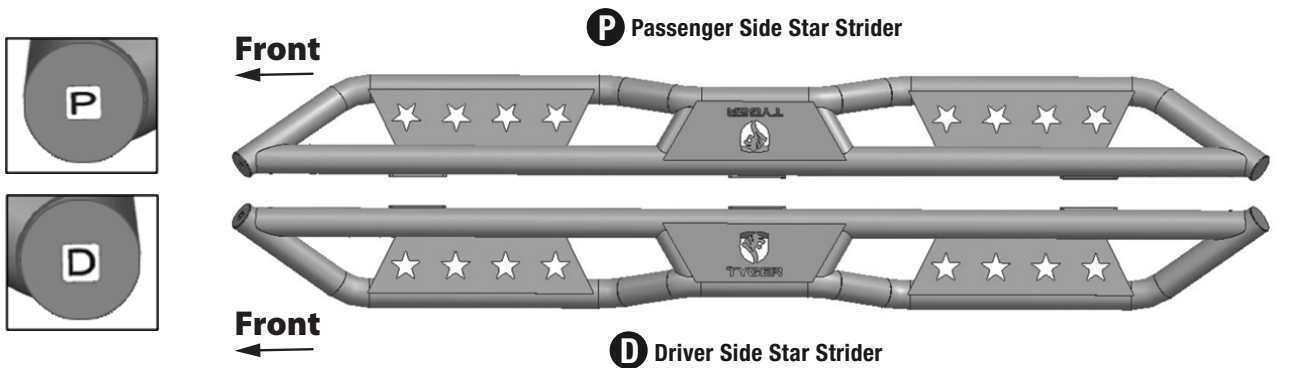

Reference the letters printed on the brackets to determine mounting locations

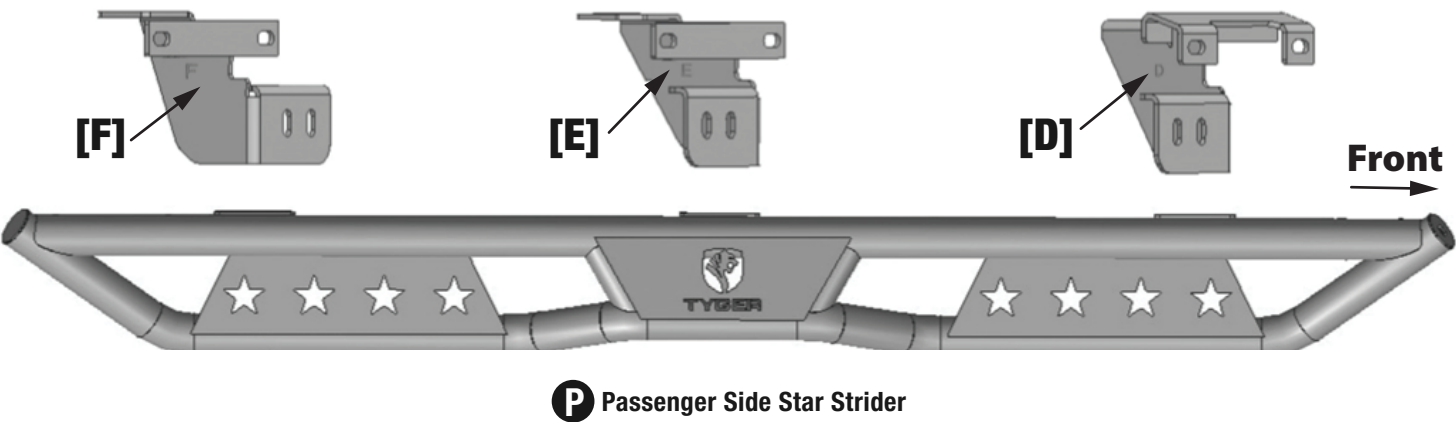
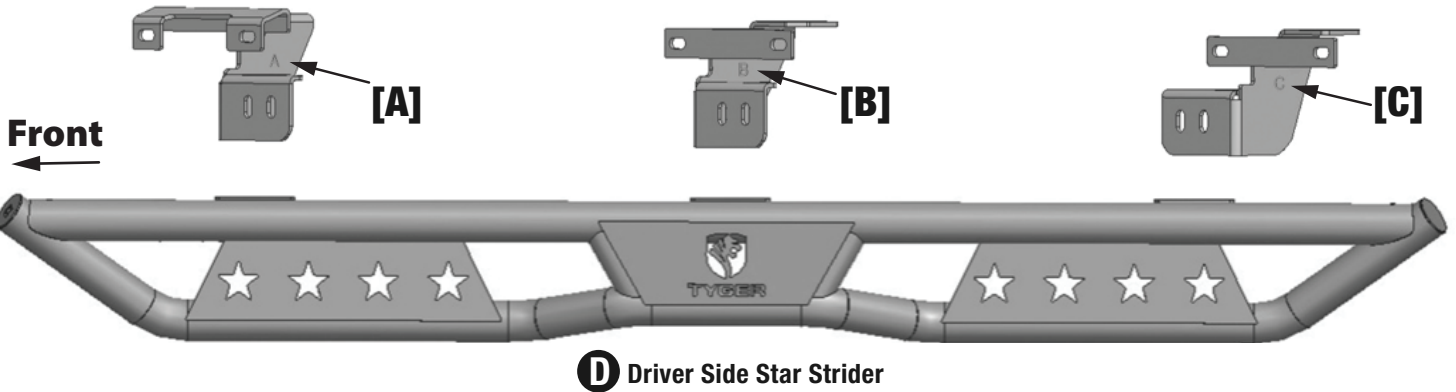

**Bottom View**

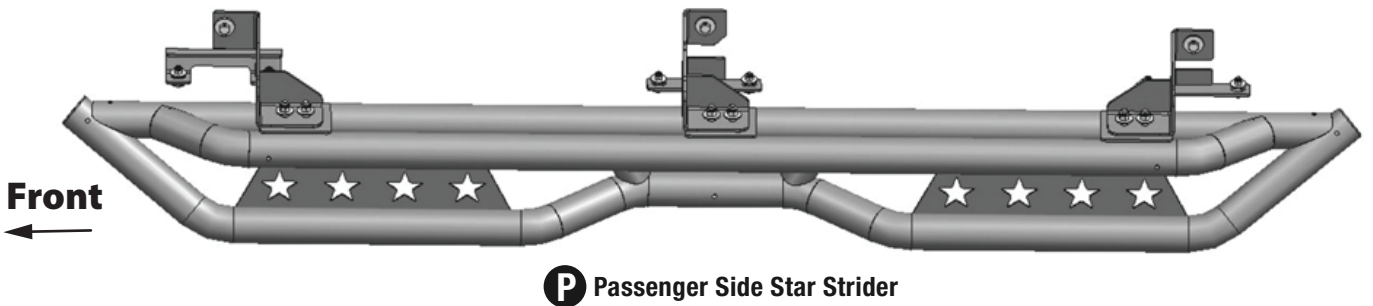
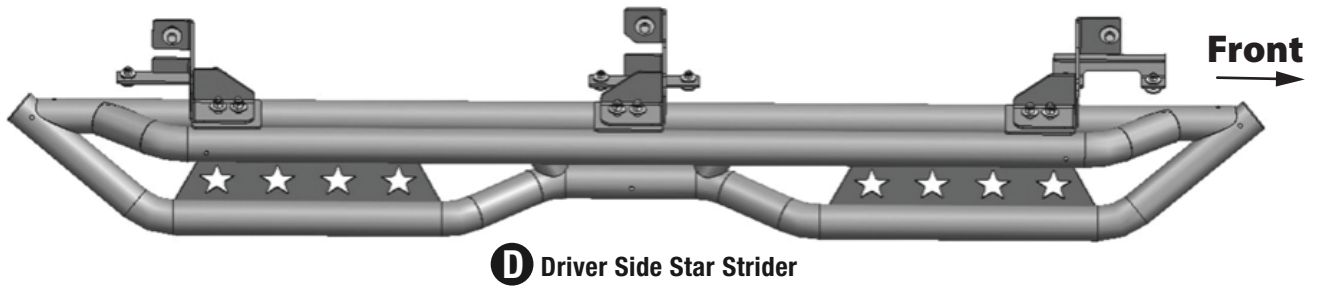

**TOOLS REQUIRED**

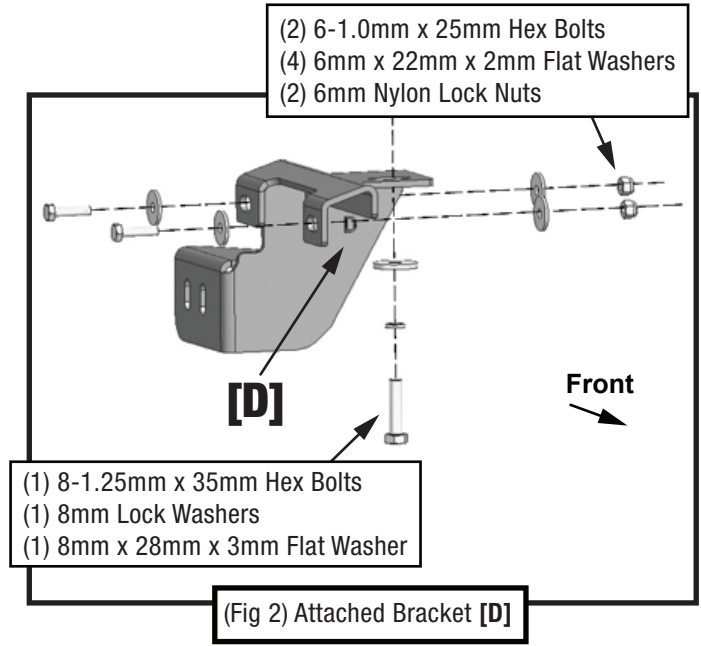
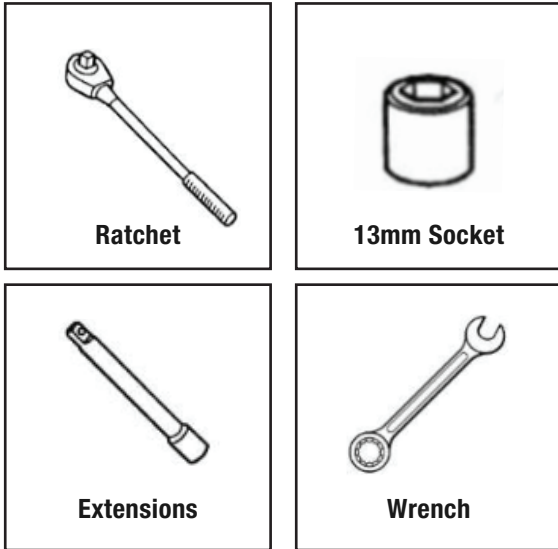

**STEP 1 MOUNTING BRACKETS**

Follow (Fig 1-9) to attach the brackets to the Passenger Side.

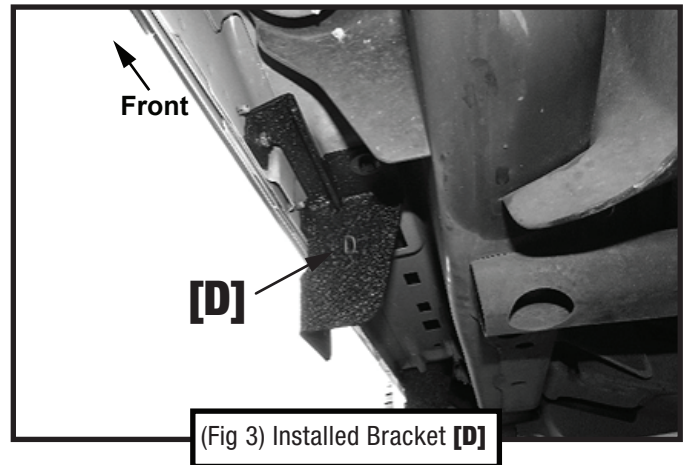
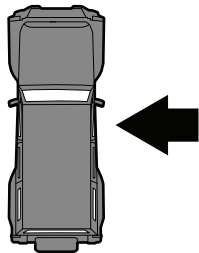

**Passenger-side Front Mounting Area**

**Passenger-side Center Mounting Area**

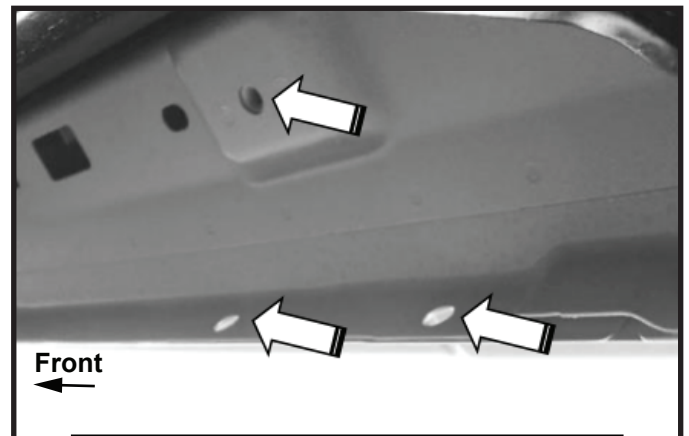
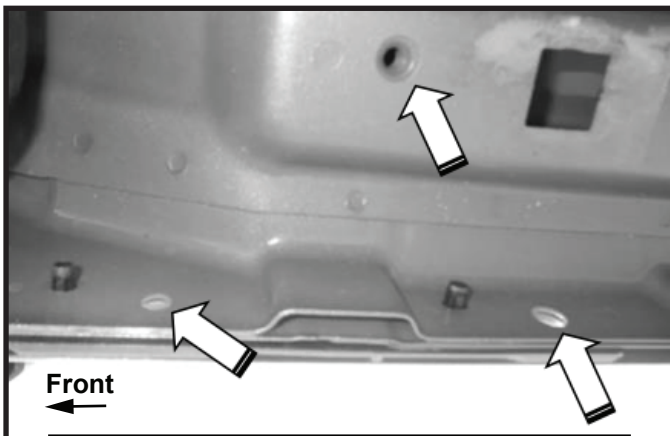

(Fig 1) Attach Bracket [D] to the Passenger/Right side front mounting location with threaded insert

(Fig 4) Attach Bracket [E] to the Passenger/Right side center mounting location with threaded insert

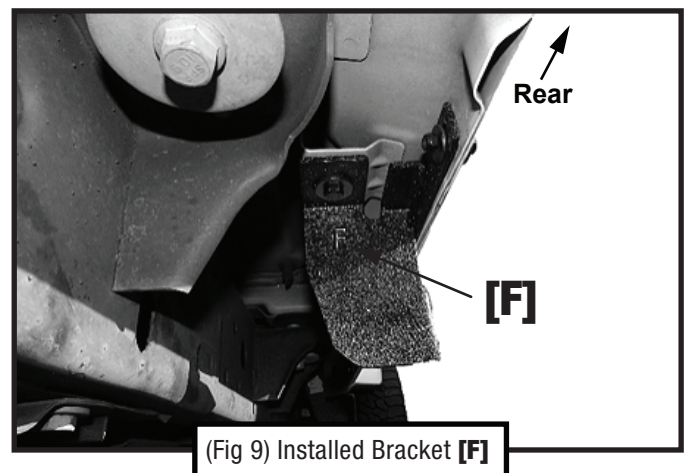
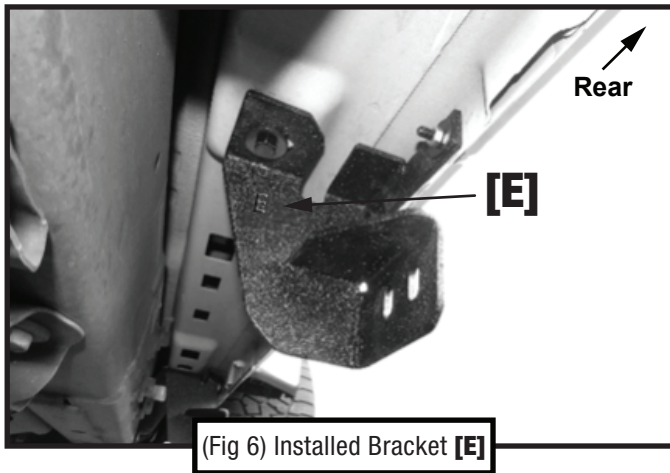
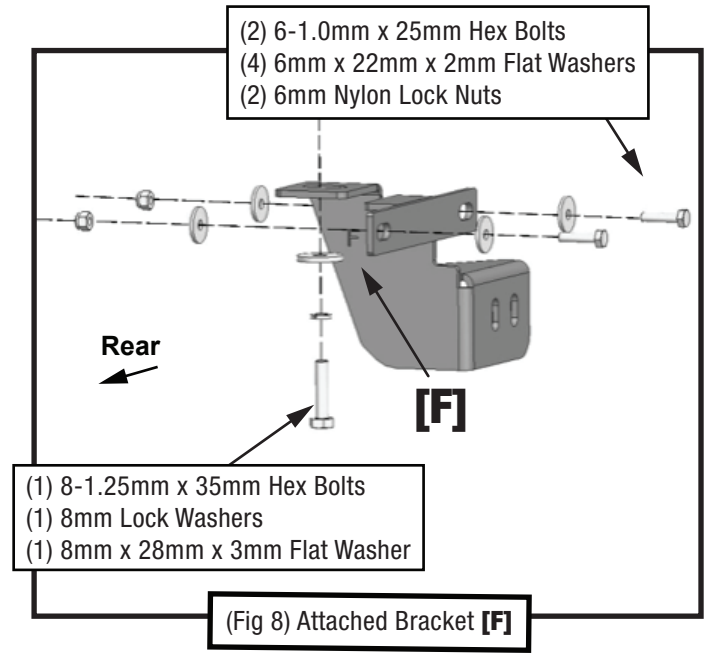
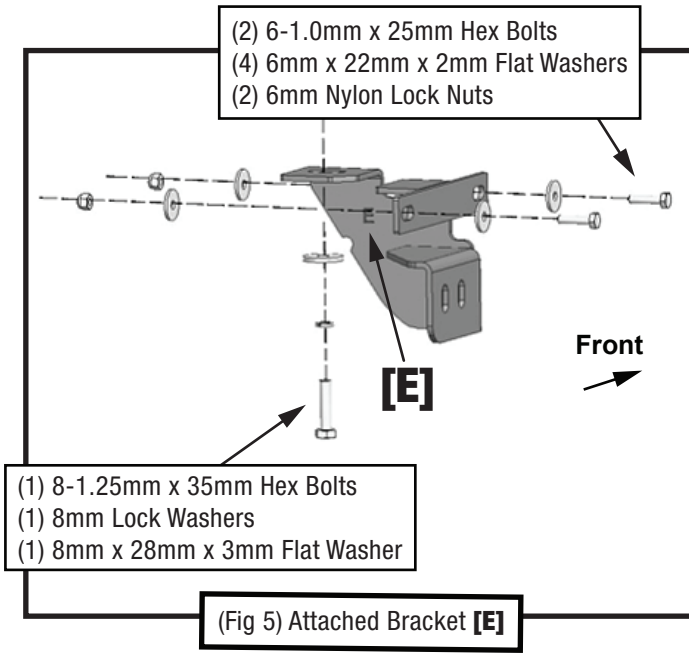

**Passenger-side Rear Mounting Area**

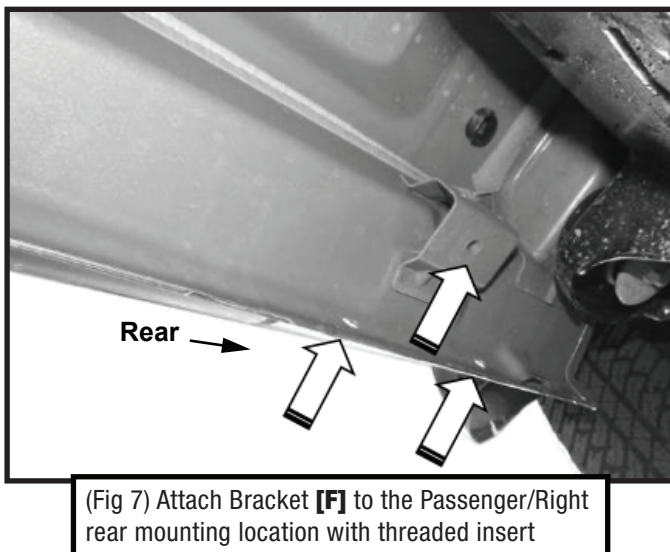

## STEP 2 MOUNTING RUNNING BOARDS

Follow (Figs 10-11) to install the passenger-side running board.

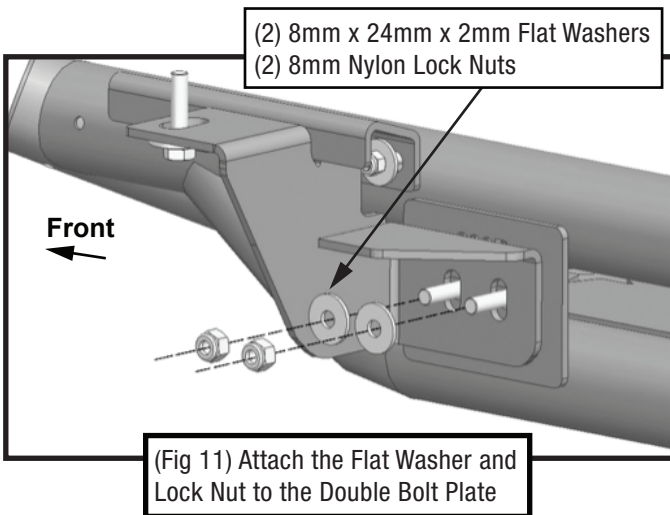
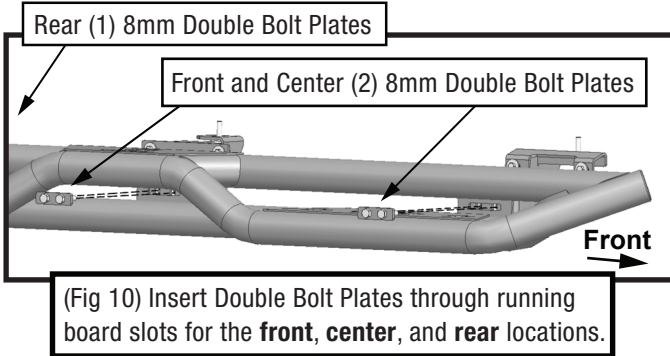

## STEP 3 DRIVER SIDE

Repeat **STEPS 1-2** for driver side installation.

- Use Bracket **[A]** instead of **[D]**;
- Use Brackets **[B]** instead of **[E]**;
- Use Brackets **[C]** instead of **[F]**.

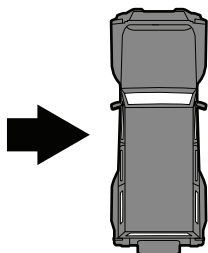

## STEP 4

Installation is complete. Do periodic inspections to the installation to make sure that all hardware is secure and tight.

