



STAR STRIDER®

TG-SR2T74938

BEFORE INSTALLATION

READ INSTRUCTIONS CAREFULLY BEFORE STARTING INSTALLATION. REMOVE CONTENTS FROM BOX AND VERIFY ALL PARTS ARE PRESENT. FAILURE TO IDENTIFY DAMAGE BEFORE INSTALLATION COULD LEAD TO A REJECTION OF ANY CLAIM. IF MISSING PARTS OR ANY DAMAGE FOUND, PLEASE TAKE A PICTURE FOR THE CLAIM PURPOSE. TO FILE YOUR CLAIM, PLEASE VISIT: WWW.TYGERAUTO.COM/CONTACT

TORQUE VALUES

Fastener Size	Class 8.8 Torque (ft-lbs)	Class 10.9 Torque (ft-lbs)
6mm	6-7	6-7
8mm	15-16	22-23
10mm	31-32	44-45
12mm	54-55	78-79
14mm	87-88	125-126

- x1** Driver Side Star Strider **[D]**
- x1** Passenger Side Star Strider **[P]**
- x1** Driver Side Front Bracket **[A]**
- x1** Passenger Side Front Bracket **[D]**
- x1** Driver Side Center Bracket **[B]**
- x1** Passenger Side Center Bracket **[E]**
- x1** Driver Side Rear Bracket **[C]**
- x1** Passenger Side Rear Bracket **[F]**
- x1** Driver Side Support Bracket **[G]**
- x1** Passenger Side Support Bracket **[H]**
- x6** 8-1.25mm x 35mm Double Bolt Plate
- x16** 8-1.25mm x 30mm Hex Bolts
- x16** 8mm Nylon Lock Nuts
- x32** 8mm x 24mm x 2mm Flat Washers
- x12** 8mm Lock Washers

Parts List

Top View

ATTENTION: Refer to **[D]** and **[P]** labelling on the side of the tubes to determine Driver and Passenger Star Striders

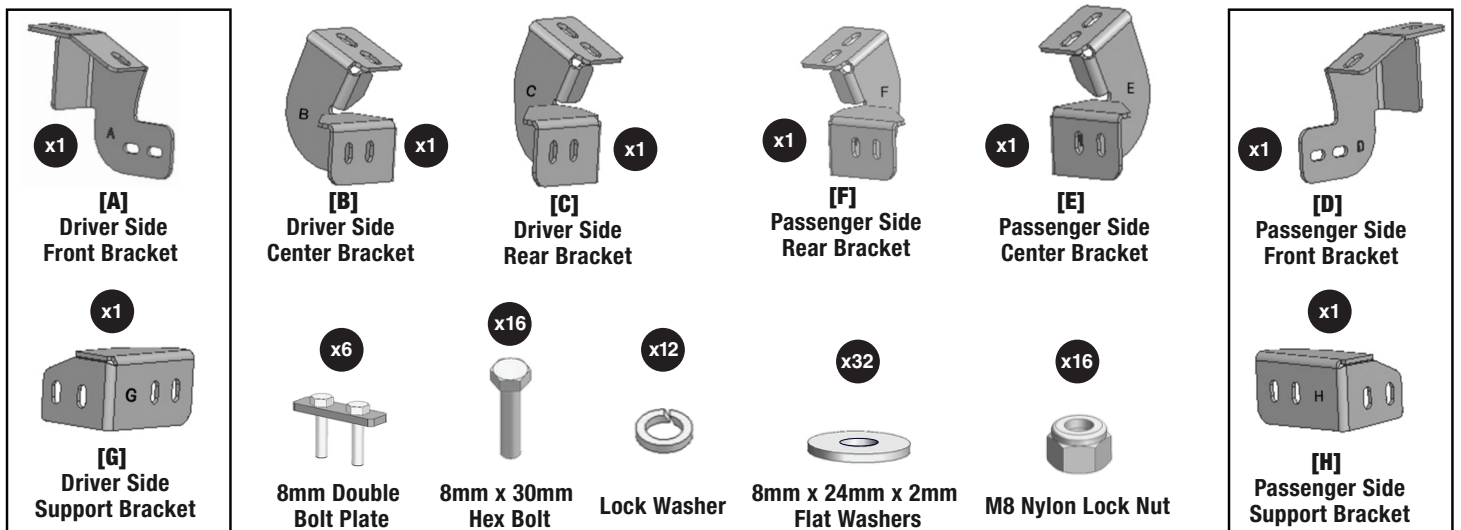
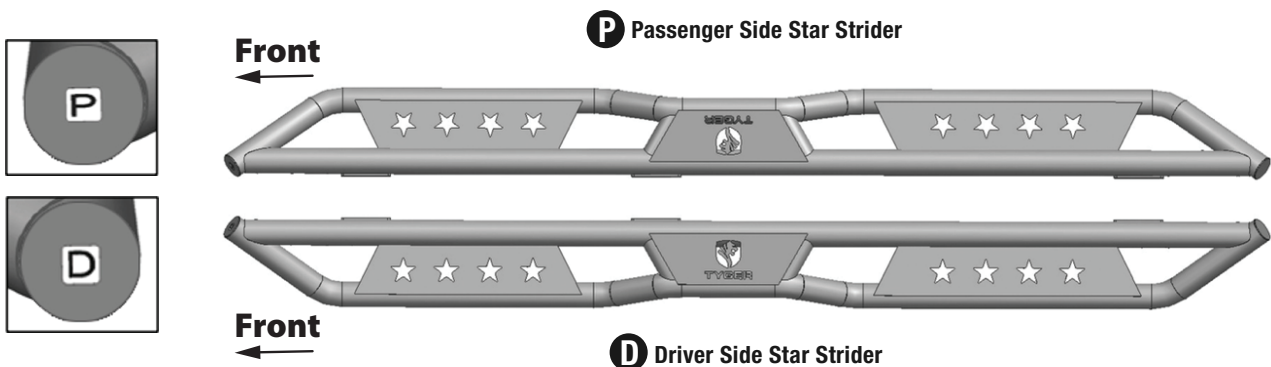

Reference the letters printed on the brackets to determine mounting locations

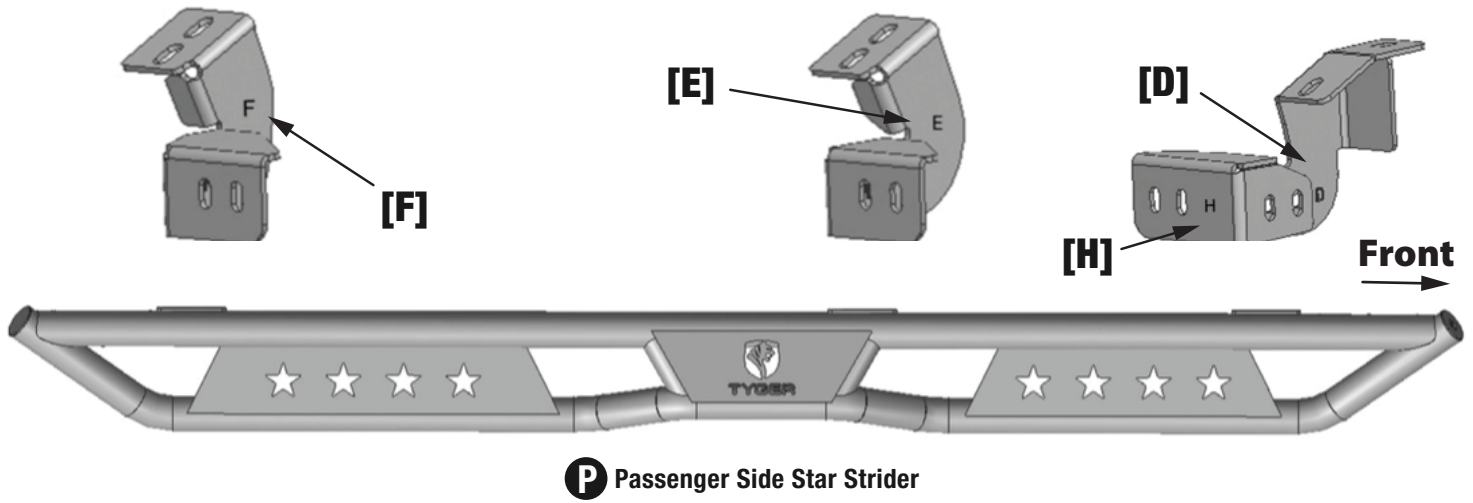
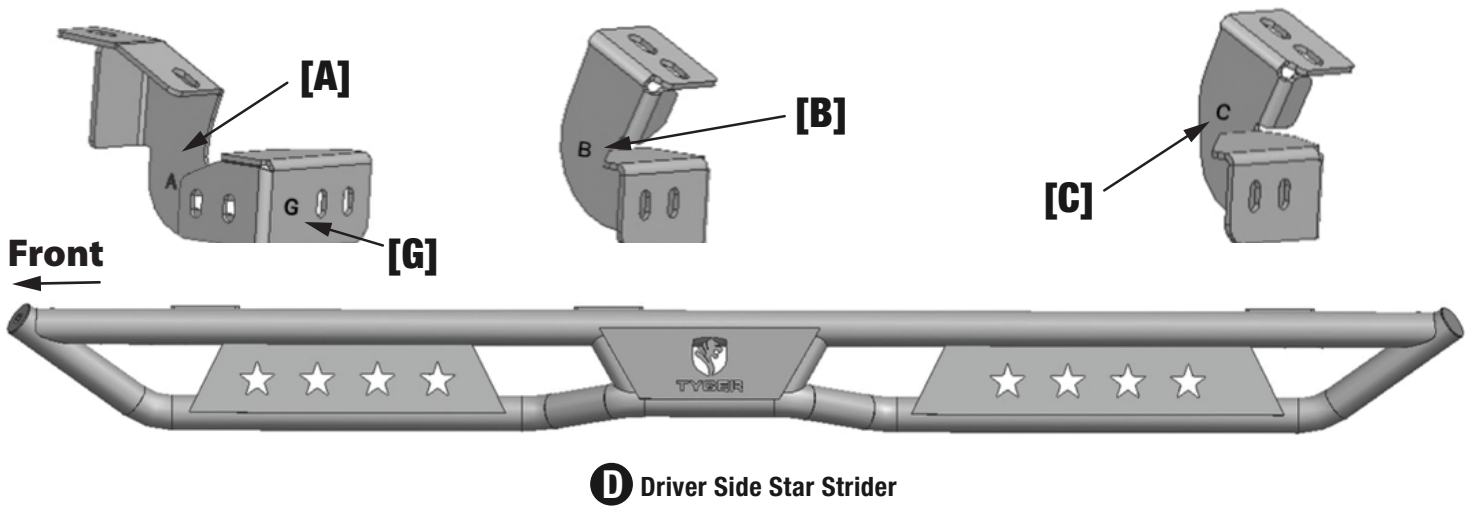

Bottom View

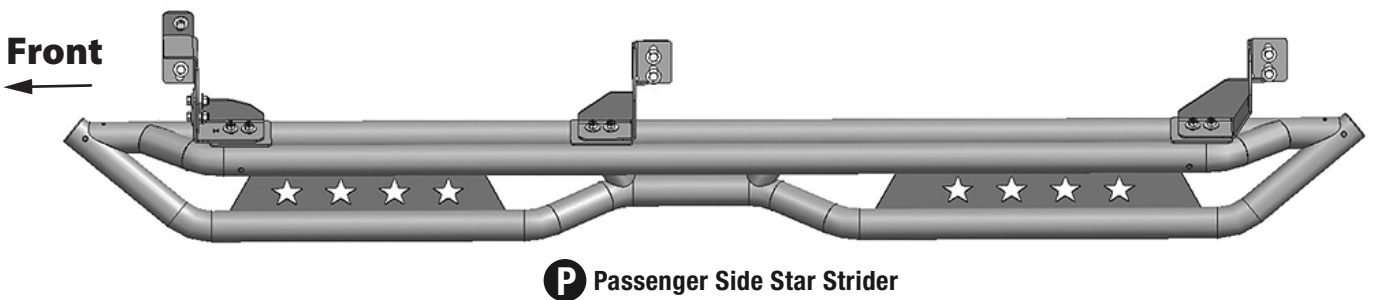
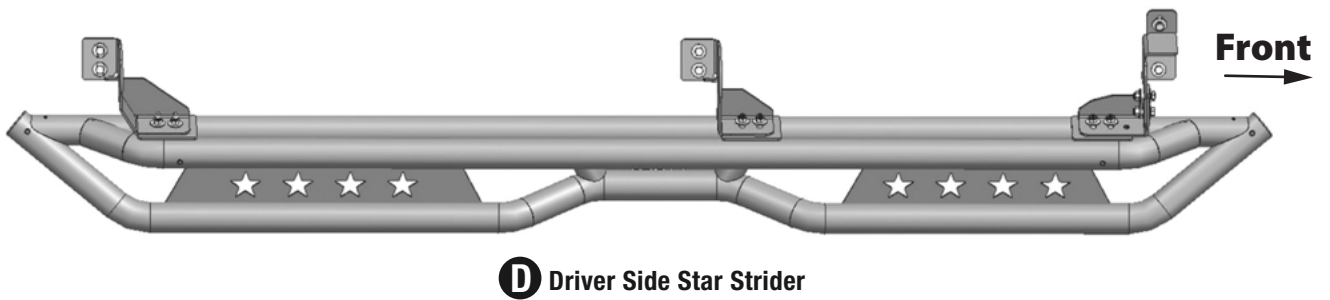

TOOLS REQUIRED

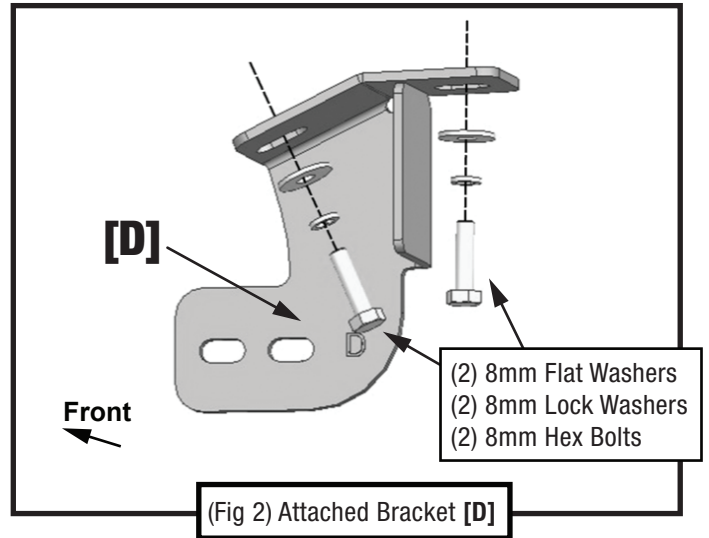
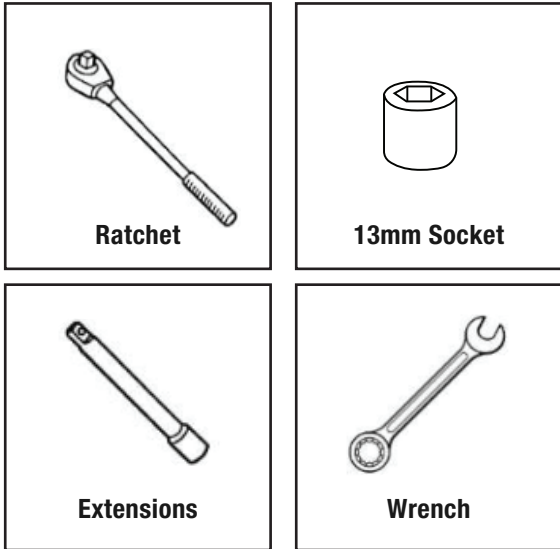

STEP 1 MOUNTING BRACKETS

Follow (Fig 1-11) to attach the brackets to the Passenger Side.

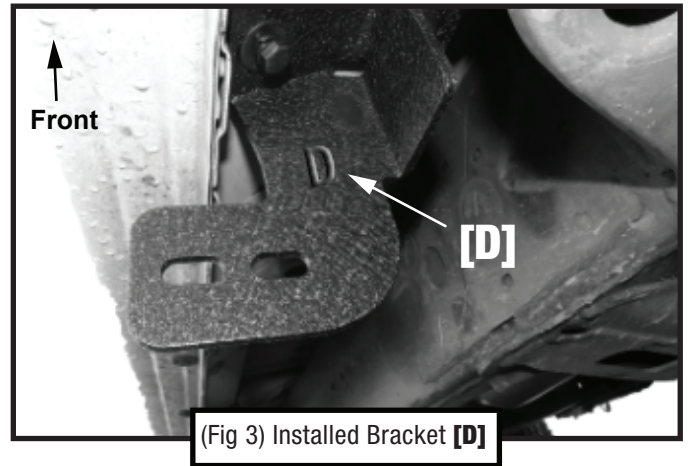
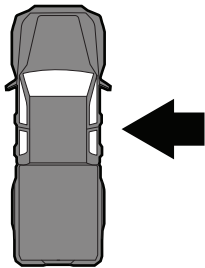

Passenger-side Front Mounting Area

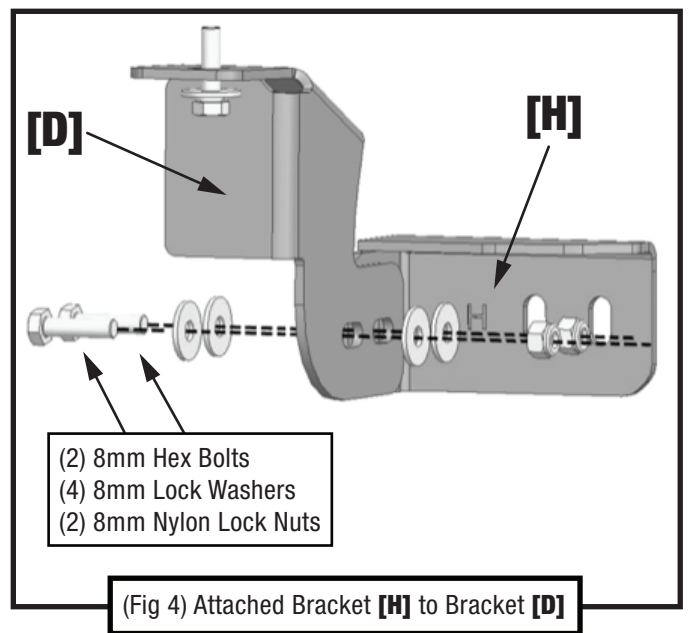
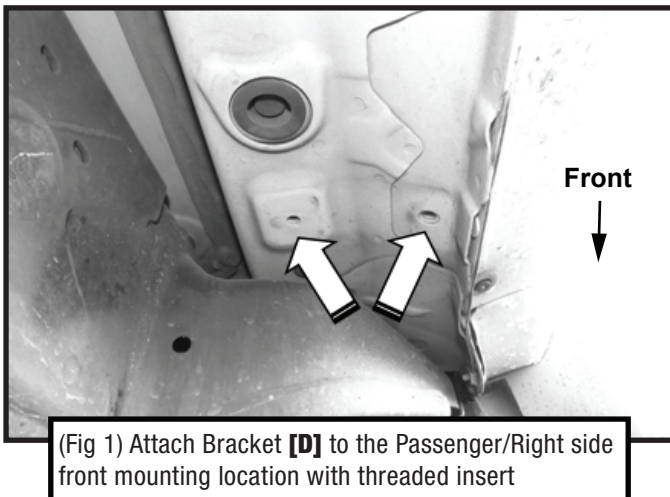

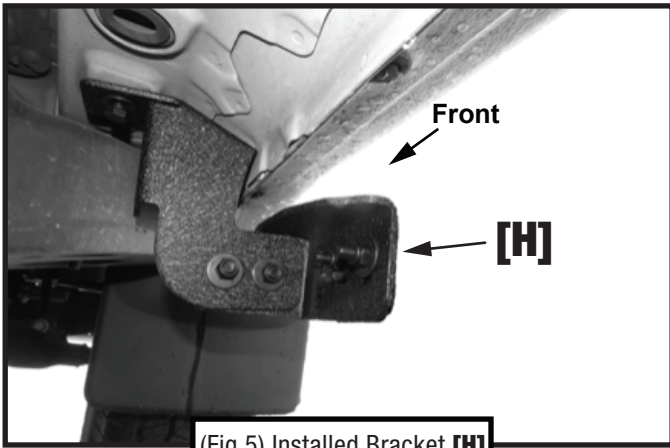

(Fig 5) Installed Bracket [H]

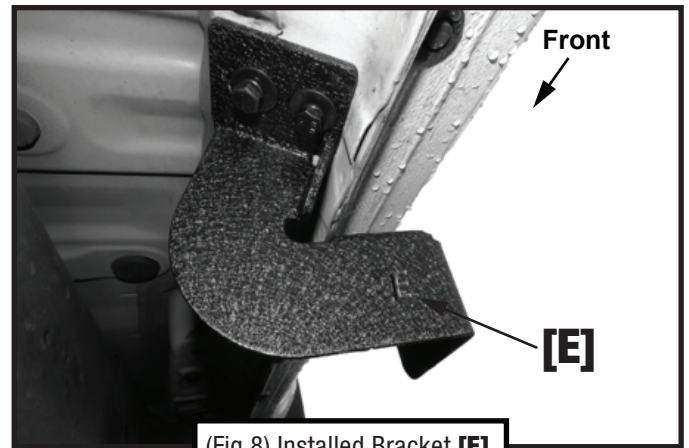

(Fig 8) Installed Bracket [E]

Passenger-side Center Mounting Area

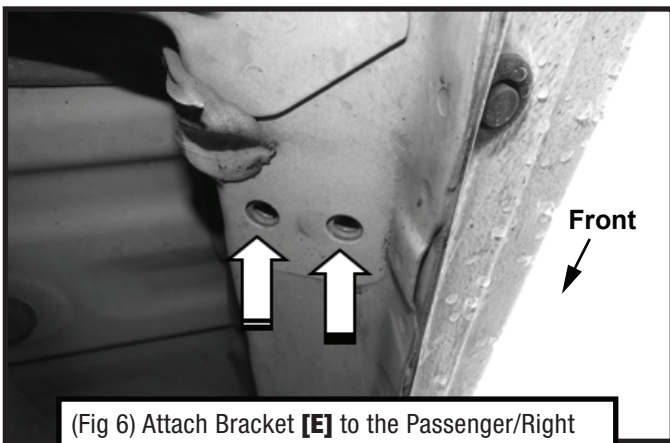

(Fig 6) Attach Bracket [E] to the Passenger/Right side center mounting location with threaded inserts

Passenger-side Rear Mounting Area

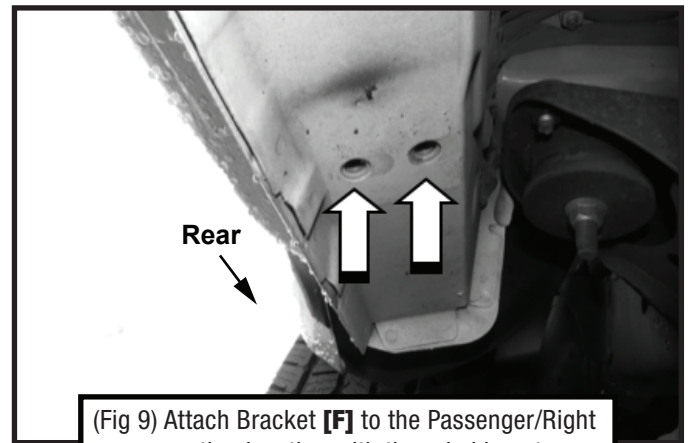

(Fig 9) Attach Bracket [F] to the Passenger/Right rear mounting location with threaded insert

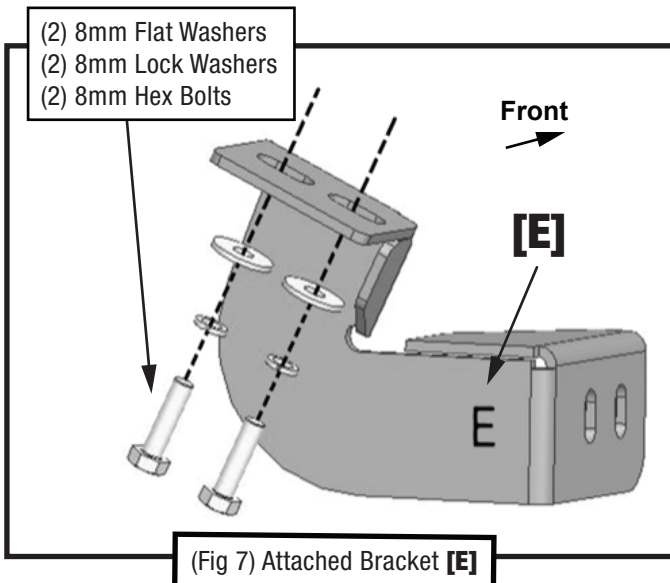

(Fig 7) Attached Bracket [E]

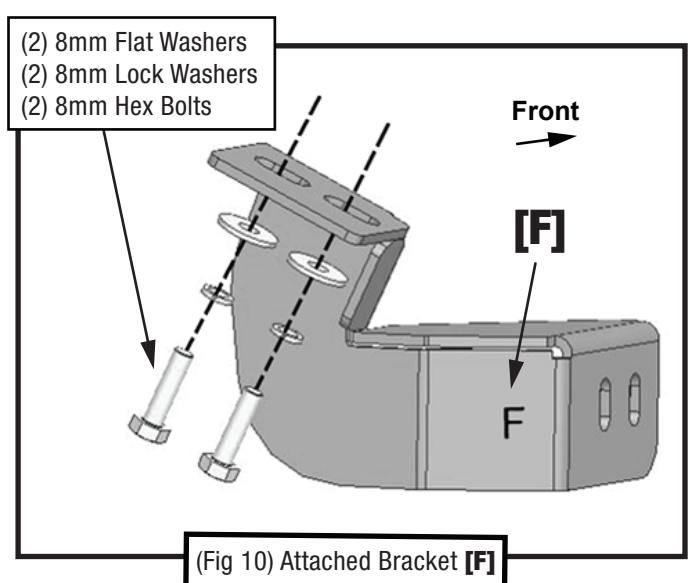

(Fig 10) Attached Bracket [F]

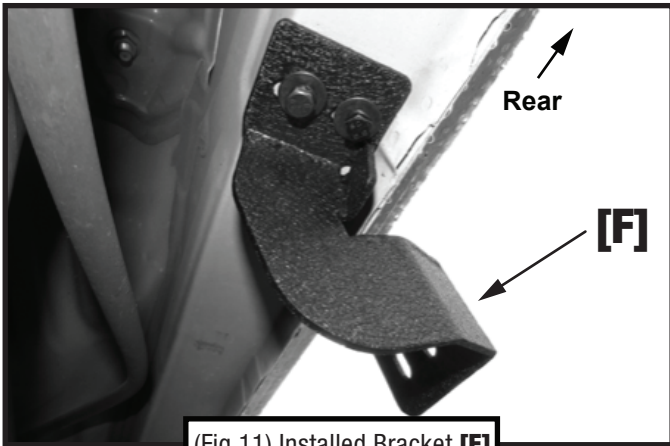

STEP 3 DRIVER SIDE

Repeat **STEPS 1-2** for driver side installation.
 Use Bracket **[A]** instead of **[D]**;
 Use Bracket **[B]** instead of **[E]**;
 Use Bracket **[C]** instead of **[F]**;
 Use Support Bracket **[G]** instead of **[H]**.

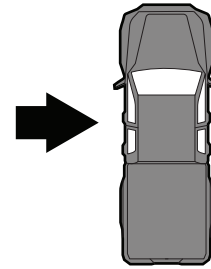

STEP 2 MOUNTING RUNNING BOARDS

Follow (Figs 12-13) to install the passenger-side running board.

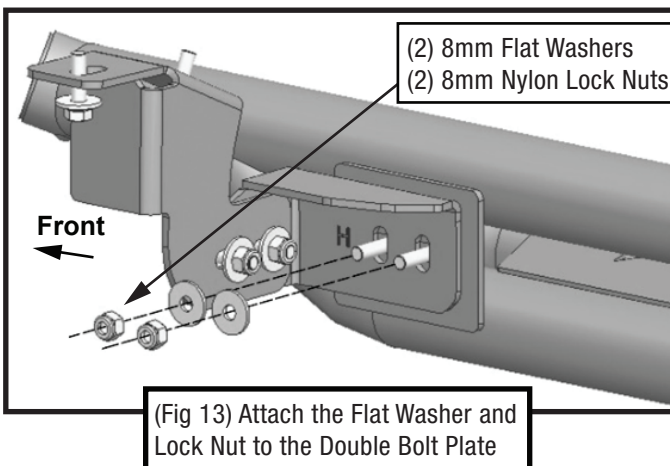
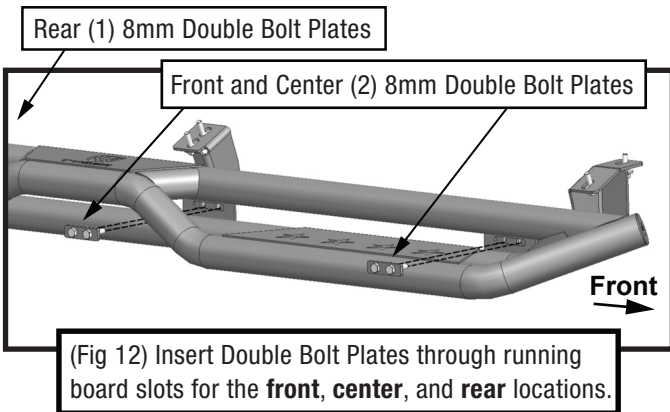

STEP 4

Installation is complete. Do periodic inspections to the installation to make sure that all hardware is secure and tight.

