



TYGER RIDER®

TG-SS2T35818

BEFORE INSTALLATION

READ INSTRUCTIONS CAREFULLY BEFORE STARTING INSTALLATION. REMOVE CONTENTS FROM BOX AND VERIFY ALL PARTS ARE PRESENT. FAILURE TO IDENTIFY DAMAGE BEFORE INSTALLATION COULD LEAD TO A REJECTION OF ANY CLAIM. IF MISSING PARTS OR ANY DAMAGE FOUND, PLEASE TAKE A PICTURE FOR THE CLAIM PURPOSE. TO FILE YOUR CLAIM, PLEASE VISIT: WWW.TYGERAUTO.COM/CONTACT

TORQUE VALUES

Fastener Size	Class 8.8 Torque (ft-lbs)	Class 10.9 Torque (ft-lbs)
6mm	6-7	6-7
8mm	15-16	22-23
10mm	31-32	44-45
12mm	54-55	78-79
14mm	87-88	125-126

- x1** Driver/Left Tyger Rider
- x1** Passenger/Right Tyger Rider
- x1** Driver/Left Front Mounting Bracket
- x1** Passenger/Right Front Mounting Bracket
- x3** Driver/Left Center/Rear Mounting Brackets
- x3** Passenger/Right Center/Rear Mounting Brackets
- x16** 8mm x 30mm Hex Bolts
- x16** 8mm x 25mm Combo Bolts
- x16** 8mm Lock Washers
- x16** 8mm x 24mm OD x 2mm Flat Washers

Parts List

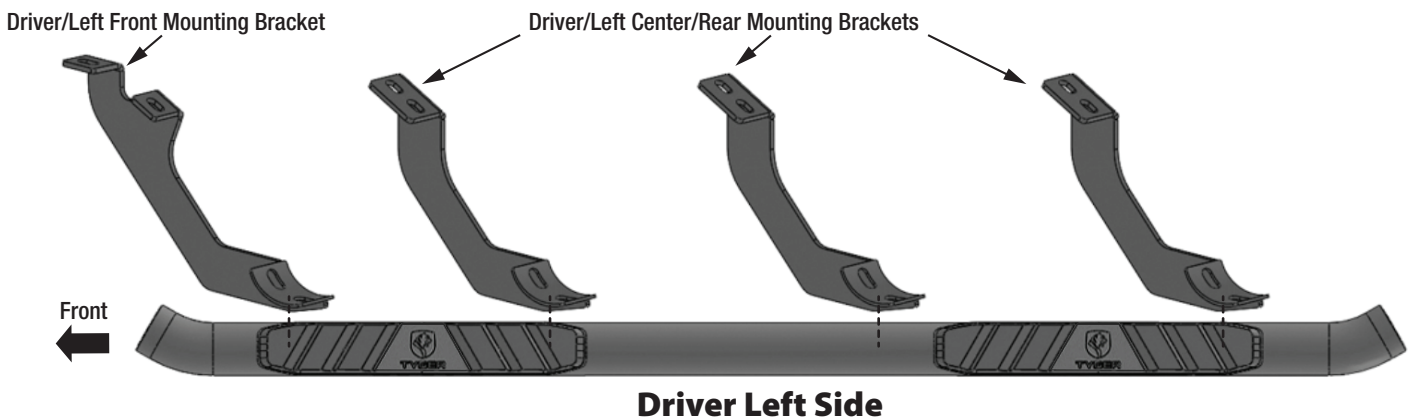
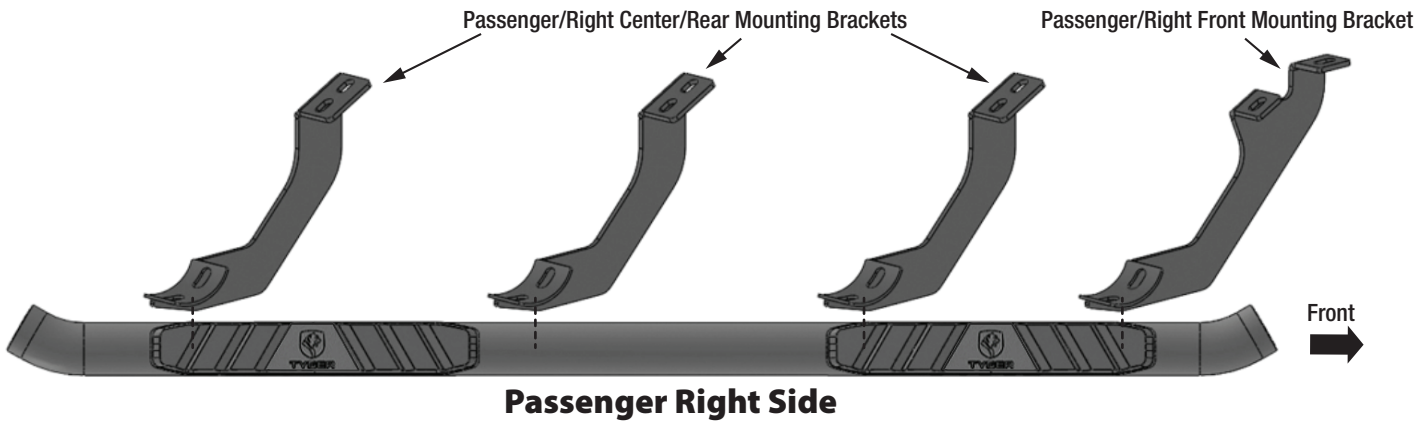

Bottom View



Passenger Right Side



Driver Left Side

PROCEDURE:

REMOVE CONTENTS FROM BOX. VERIFY ALL PARTS ARE PRESENT. READ INSTRUCTIONS CAREFULLY. ASSISTANCE IS HIGHLY RECOMMENDED.

STEP 1

Starting on the Passenger/Right side of the vehicle and remove the plastic plugs or hex bolts from the factory mounting location along the bottom of the body (Figs 1 & 2).

Passenger/Right Side Installation Pictured

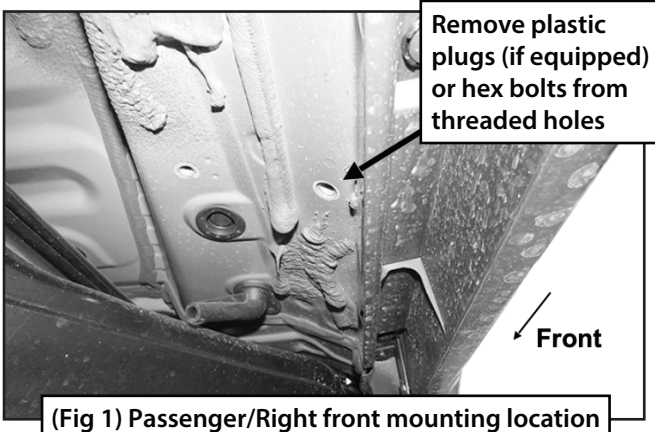

STEP 2

Select the Passenger/Right Front Mounting Bracket. Attach the Bracket to the front location with (2) 8mm Hex Bolts, (2) 8mm Lock Washers and (2) 8mm Flat Washers (Figs 3 & 4). DO NOT tighten hardware.

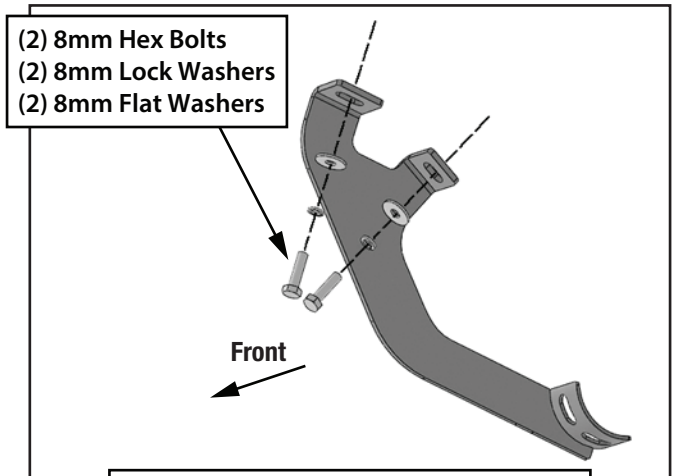

(Fig 3) Attach the Passenger/Right Front Mounting Bracket to the front location



STEP 3

Repeat **STEPS 1 & 2** to attach the (3) Passenger/Right Center/Rear Mounting Brackets (Figs 4-8).

Passenger/Right Side Installation Pictured

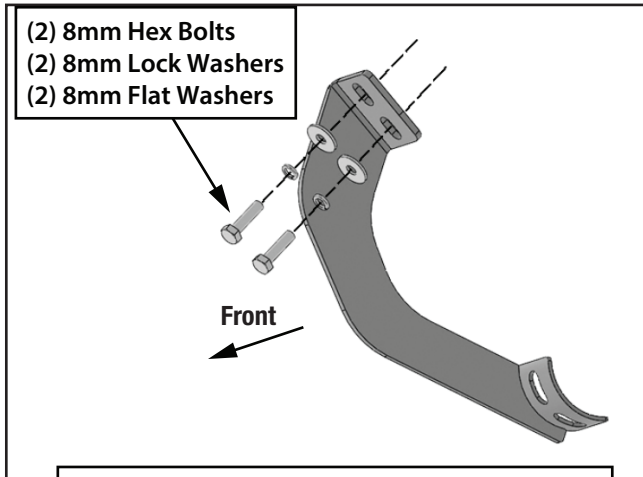

(Fig 5) Attach (1) Passenger/Right Center/Rear Mounting Bracket to the 2nd location

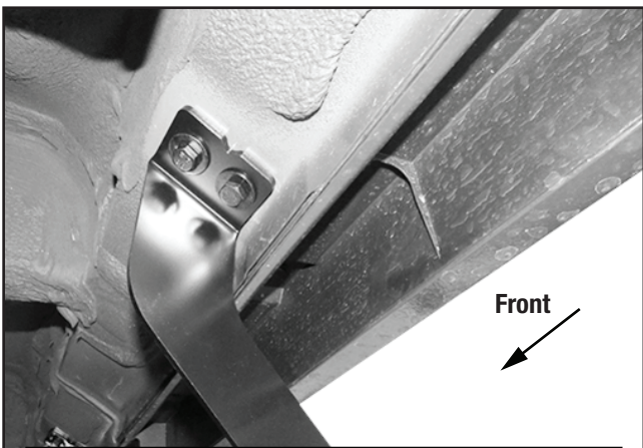

(Fig 6) (1) Passenger/Right Center/Rear Mounting Bracket attached to the 2nd location



(Fig 7) (1) Passenger/Right Center/Rear Mounting Bracket attached to the 3rd location

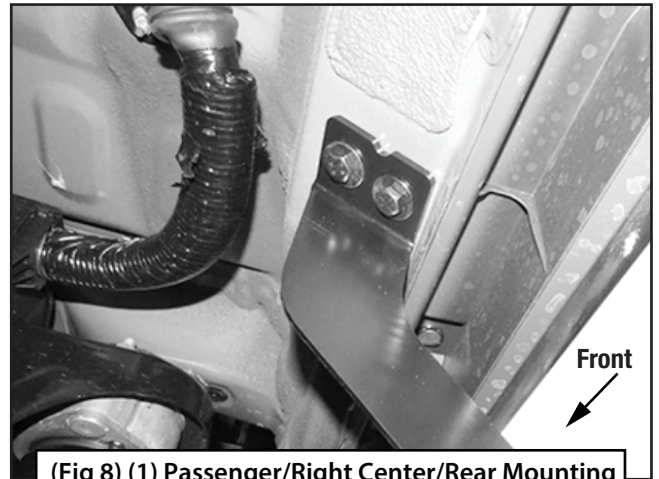

(Fig 8) (1) Passenger/Right Center/Rear Mounting Bracket attached to the rear location

STEP 4

Select the Passenger/Right Tyger Rider. Place the Tyger Rider onto the cradles of the Mounting Brackets. **IMPORTANT:** DO NOT Slide front to back or rotate the Tyger Rider or damage may result. Attach the Tyger Rider to the Mounting Brackets with (6) 8mm Combo Bolts (Fig 9). DO NOT tighten hardware.

Passenger/Right Side Installation Pictured

(Fig 9) Attach the Passenger/Right Tyger Rider to the (4) Mounting Brackets

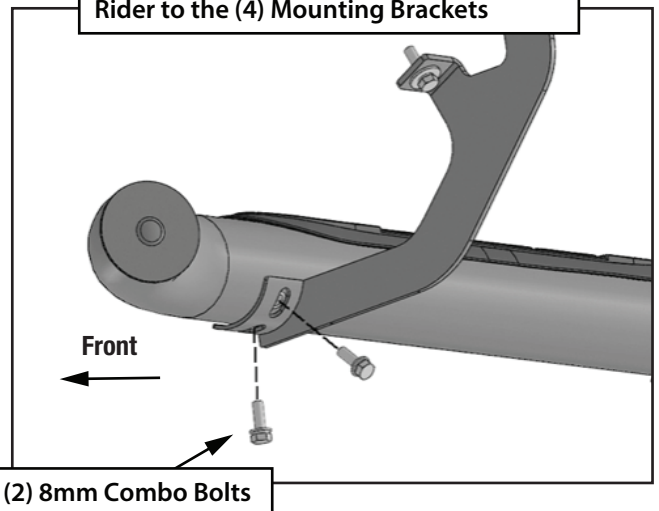

STEP 5

Level and adjust the Tyger Rider and tighten all hardware.

STEP 6

Repeat **STEPS 1-5** to attach the Driver/Left Tyger Rider.

STEP 7

Do periodic inspections to the installation to make sure that all hardware is secure and tight.