



TYGER TRAX

TG-TX7D29398

Scan to Download the Latest Digital Version



BEFORE INSTALLATION

READ INSTRUCTIONS CAREFULLY BEFORE STARTING INSTALLATION. REMOVE CONTENTS FROM BOX AND VERIFY ALL PARTS ARE PRESENT. FAILURE TO IDENTIFY DAMAGE BEFORE INSTALLATION COULD LEAD TO A REJECTION OF ANY CLAIM. IF MISSING PARTS OR ANY DAMAGE FOUND, PLEASE TAKE A PICTURE FOR THE CLAIM PURPOSE. TO FILE YOUR CLAIM, PLEASE VISIT: WWW.TYGERAUTO.COM/CONTACT

TORQUE VALUES

Fastener Size	Class 8.8 Torque (ft-lbs)	Class 10.9 Torque (ft-lbs)
6mm	6-7	6-7
8mm	15-16	22-23
10mm	31-32	44-45
12mm	54-55	78-79
14mm	87-88	125-126

- x1 Driver/Left TYGER TRAX
- x1 Passenger/Right TYGER TRAX
- x2 Front Upper Mounting Brackets (E)
- x2 Front Lower Mounting Brackets (A)
- x2 Center Mounting Brackets (B)
- x2 Rear Mounting Brackets (C)
- x4 Center/Rear Support Brackets (D)
- x4 8mm x 25mm Hex Bolts
- x12 8mm x 25mm Combo Bolts
- x22 8mm x 24mm OD x 2mm Flat Washers
- x8 8mm x 16mm OD x 1.6mm Flat Washers
- x26 8mm Nylon Lock Nuts

Parts List

Reference the letters printed on the brackets to determine mounting locations

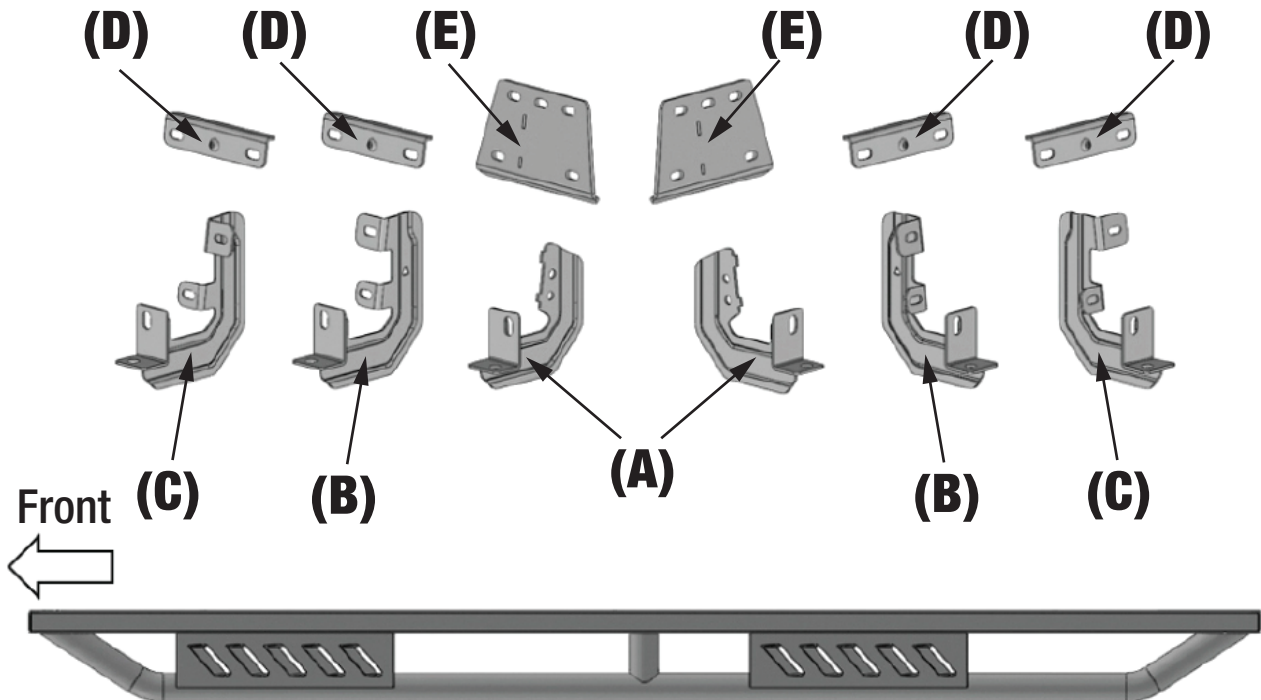

Driver/Left TYGER TRAX

Bottom View

ATTENTION: Refer to the D or P labelling on the tubes to determine the Driver or Passenger side steps.

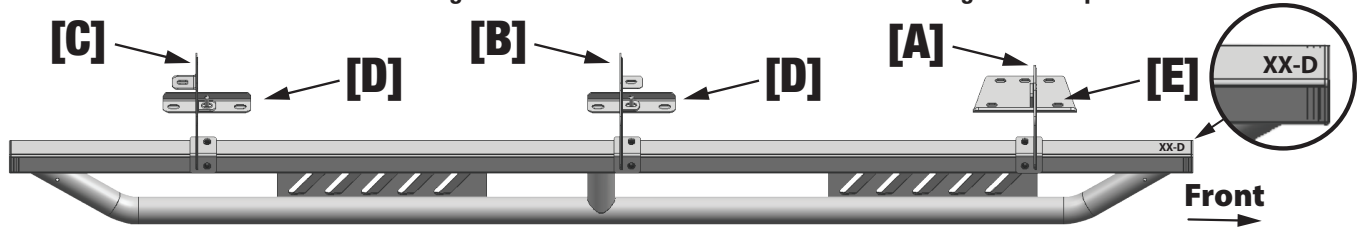

Driver Left Side

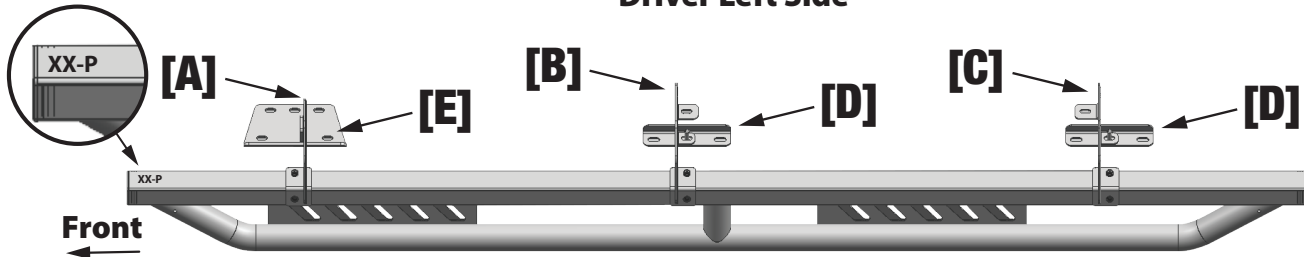

Passenger Right Side

PROCEDURE:

REMOVE CONTENTS FROM BOX. VERIFY ALL PARTS ARE PRESENT. READ INSTRUCTIONS CAREFULLY BEFORE STARTING INSTALLATION. USE WIRE BRUSH TO CLEAN MOUNTING STUDS OF PAINT AND DEBRIS.

STEP 1

Start the installation under the Driver/Left side of the vehicle. Locate the front (3) factory studs along the inner side of the body panel (Fig 1).

Driver/Left side Installation Pictured

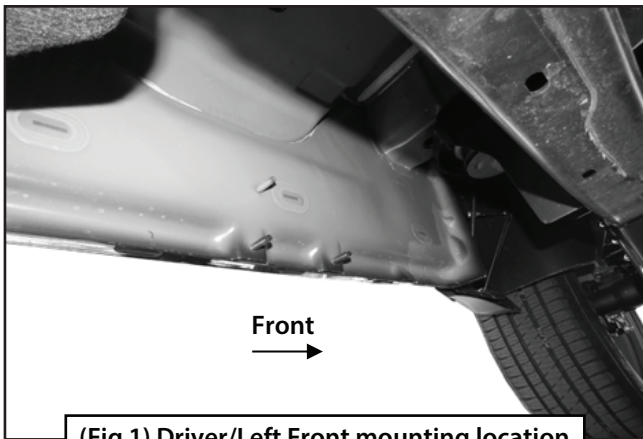

(Fig 1) Driver/Left Front mounting location

STEP 2

Select (1) Front Upper Mounting Bracket (E). Attach the Mounting Bracket (E) to the (3) factory studs with (3) 8mm x 24mm Flat Washers and (3) 8mm Nylon Lock Nuts (Fig 2). DO NOT tighten hardware.

Driver/Left side Installation Pictured

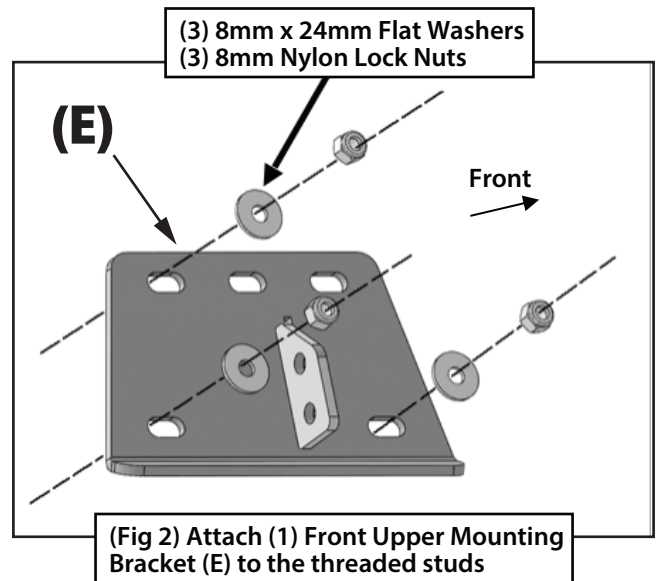

(Fig 2) Attach (1) Front Upper Mounting Bracket (E) to the threaded studs

STEP 3

Select (1) Front Lower Mounting Bracket (A). Attach the Lower Bracket (A) to the short side of the Upper Bracket (E) with (2) 8mm Hex Bolts, (4) 8mm x 16mm Flat Washers and (2) 8mm Nylon Lock Nuts (Fig 3). DO NOT tighten hardware.

Driver/Left side Installation Pictured

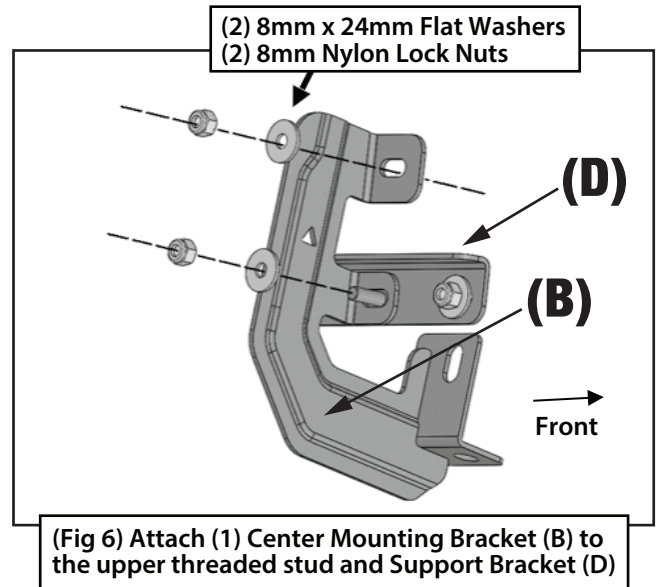
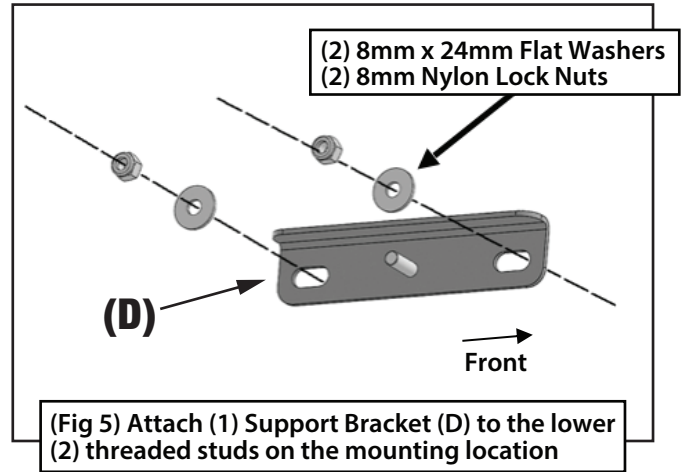
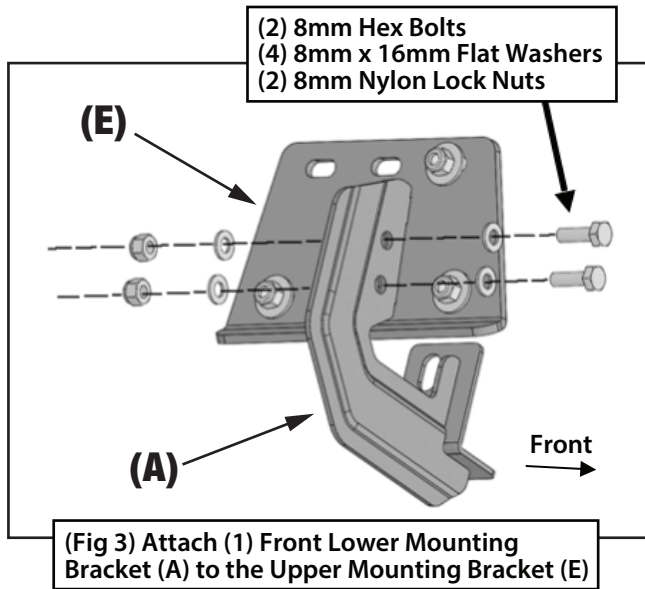

STEP 4

Move to the center location (Fig 4). Select (1) Support Bracket (D). Attach the Support Bracket (D) to the (2) lower threaded studs with (2) 8mm x 24mm Flat Washers and (2) 8mm Nylon Lock Nuts (Fig 5). Select (1) Center Mounting Bracket (B) and attach to the Support Bracket (D) and upper threaded stud with (2) 8mm x 24mm Flat Washers and (2) 8mm Nylon Lock Nuts (Fig 6). DO NOT tighten hardware.

Driver/Left side Installation Pictured

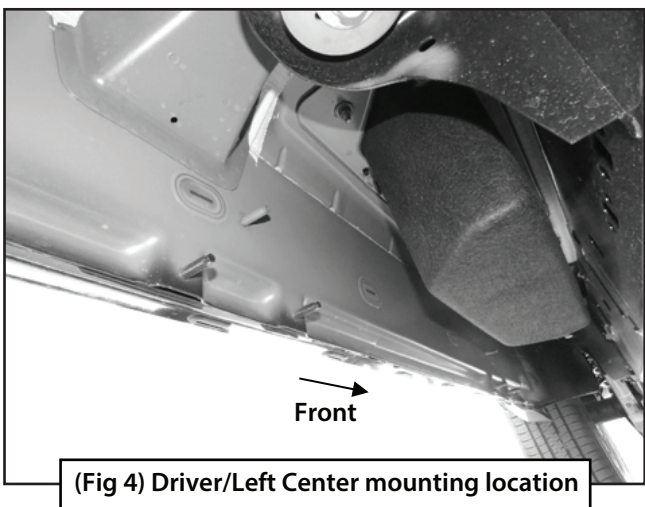

STEP 5

Repeat **STEP 4** to attach (1) Rear Mounting Bracket (C) and (1) Support Bracket (D) to the rear mounting location (Fig 7). DO NOT tighten hardware.

Driver/Left side Installation Pictured

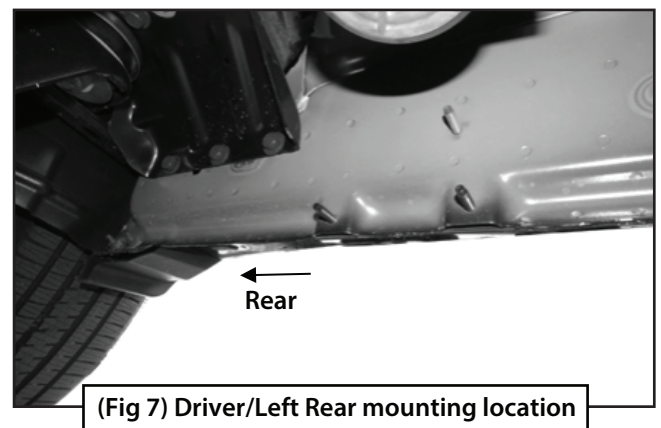

STEP 6

Select the Driver/Left TYGER TRAX. With assistance, place the Sidebar onto the (3) Mounting Brackets. **IMPORTANT:** DO NOT slide on the Brackets or damage to the finish may result (Fig 8). DO NOT tighten hardware.

Driver/Left side Installation Pictured

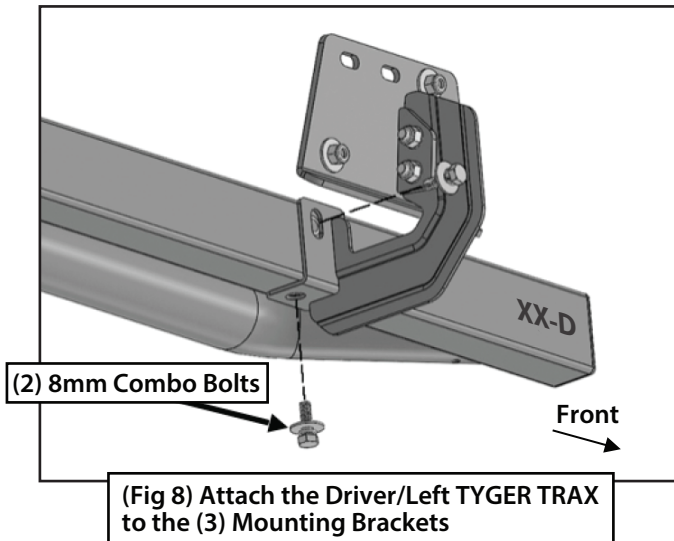

STEP 7

Level and adjust the Sidebar as necessary, then fully tighten all hardware.

STEP 8

Repeat **STEPS 1-7** to attach the Passenger/Right TYGER TRAX.

STEP 9

Do periodic inspections to the installation to make sure that all hardware is secure and tight.