



TYGER TRAX

TG-TX7J27608

Scan to Download the Latest Digital Version



BEFORE INSTALLATION

READ INSTRUCTIONS CAREFULLY BEFORE STARTING INSTALLATION. REMOVE CONTENTS FROM BOX AND VERIFY ALL PARTS ARE PRESENT. FAILURE TO IDENTIFY DAMAGE BEFORE INSTALLATION COULD LEAD TO A REJECTION OF ANY CLAIM. IF MISSING PARTS OR ANY DAMAGE FOUND, PLEASE TAKE A PICTURE FOR THE CLAIM PURPOSE. TO FILE YOUR CLAIM, PLEASE VISIT: WWW.TYGERAUTO.COM/CONTACT

TORQUE VALUES

Fastener Size	Class 8.8 Torque (ft-lbs)	Class 10.9 Torque (ft-lbs)
6mm	6-7	6-7
8mm	15-16	22-23
10mm	31-32	44-45
12mm	54-55	78-79
14mm	87-88	125-126

- x1 Driver/Left TYGER TRAX
- x1 Passenger/Right TYGER TRAX
- x1 Driver/Left Front Mounting Bracket (A)
- x1 Passenger/Right Front Mounting Bracket (D)
- x1 Driver/Left Center Mounting Bracket (B)
- x1 Passenger/Right Center Mounting Bracket (E)
- x1 Driver/Left Rear Mounting Bracket (C)
- x1 Passenger/Right Rear Mounting Bracket (F)
- x3 Driver/Left Support Brackets (G)
- x3 Passenger/Right Support Brackets (H)
- x6 10mm x 35mm Hex Bolts
- x6 10mm x 30mm Hex Bolts
- x6 10mm x 34mm OD x 3mm Flat Washers
- x12 10mm x 20mm OD x 2mm Flat Washers
- x6 10mm Lock Washers
- x6 10mm Nylon Lock Nuts
- x6 10mm Nut Plates
- x6 8mm x 35mm Hex Bolts
- x12 8mm x 25mm Combo Bolts
- x6 8mm Lock Washers
- x6 8mm x 28mm OD x 3mm Flat Washers
- x12 6mm x 25mm Hex Bolts
- x24 6mm x 22mm OD x 2mm Flat Washers
- x12 6mm Nylon Lock Nuts

Parts List

Reference the letters printed on the brackets to determine mounting locations

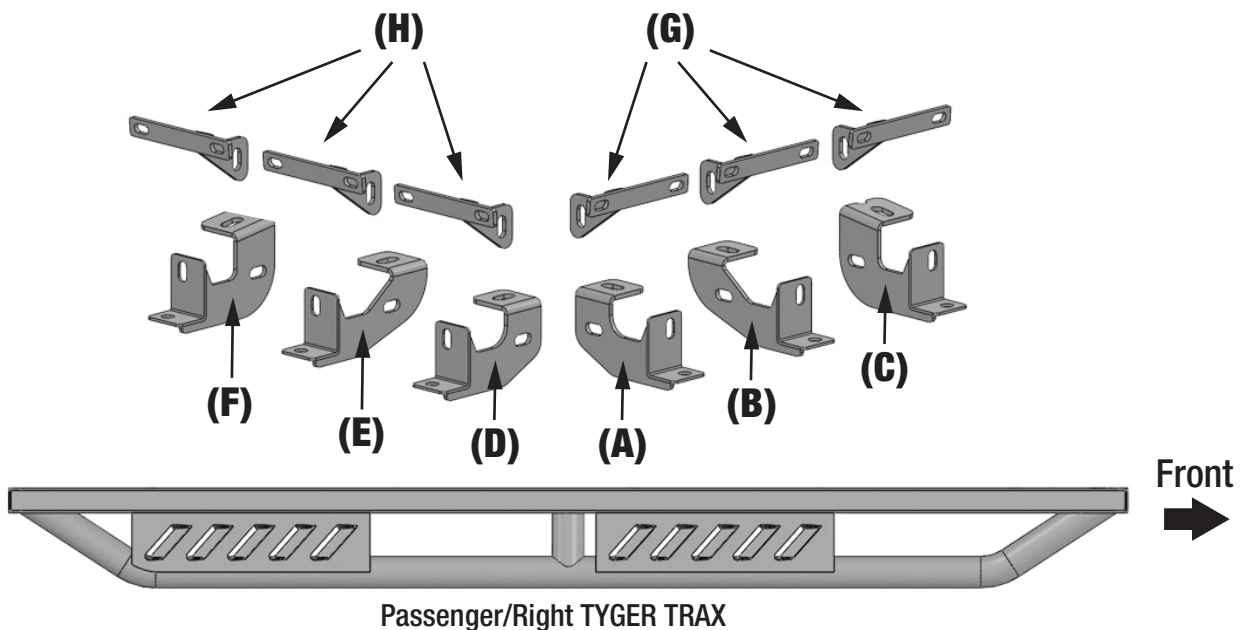

Bottom View

ATTENTION: Refer to the **D** or **P** labelling on the tubes to determine the Driver or Passenger side steps.

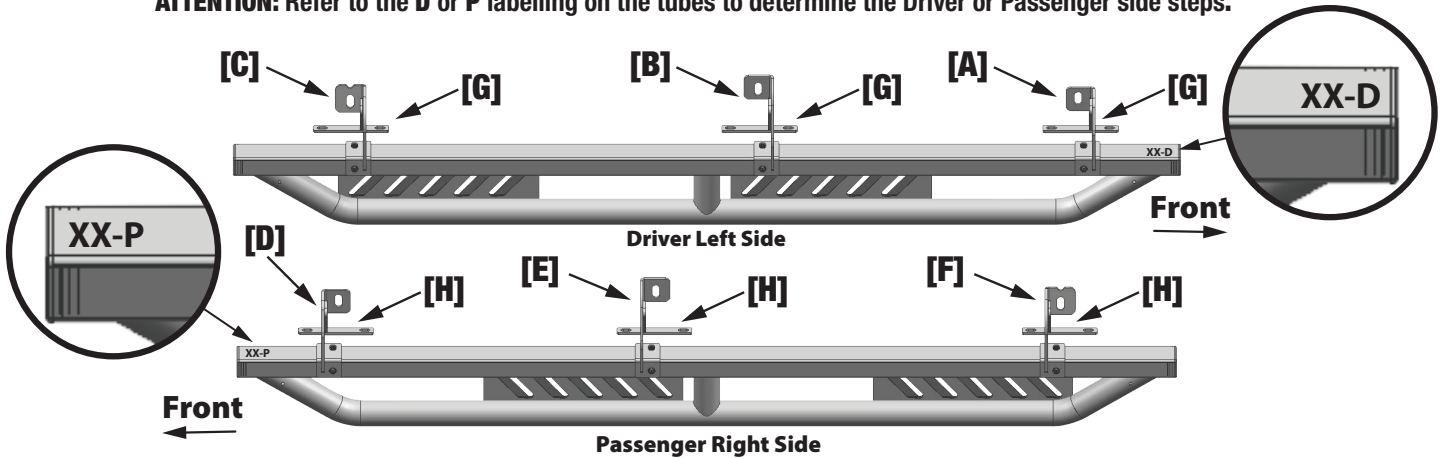

PROCEDURE:

REMOVE CONTENTS FROM BOX. VERIFY ALL PARTS ARE PRESENT. READ INSTRUCTIONS CAREFULLY. FACTORY INSTALLED OR AFTERMARKET PRODUCT MUST BE REMOVED.

STEP 1

Start installation toward the front of the Passenger/Right side of the vehicle (Fig 1).

Passenger/Right Side Installation Pictured

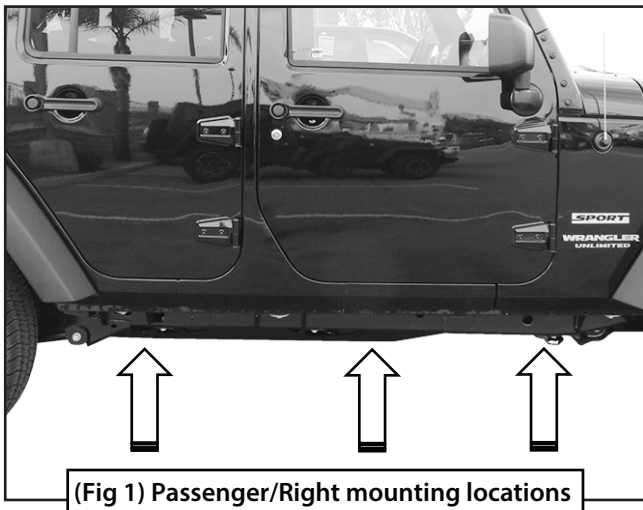

Passenger/Right Side Installation Pictured

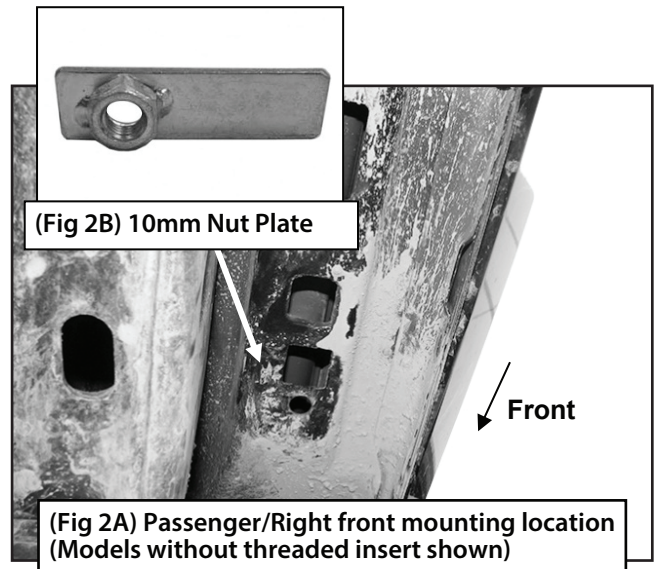

- b. Select the Passenger/Right Front Mounting Bracket (D).
- c. Attach the Bracket to the Nut Plate with (1) 10mm x 35mm Hex Bolt, (1) 10mm Lock Washer and (1) 10mm Flat x 34mm Washer (Fig 3). DO NOT tighten hardware.

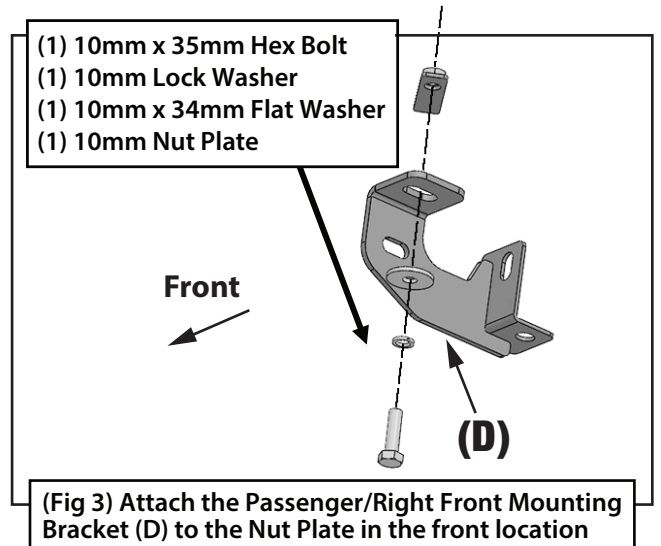

STEP 2

Determine if vehicle is equipped with threaded mounting inserts

Vehicles without threaded inserts:

- a. Insert (1) 10mm Nut Plate into the large square opening in the floor panel. Line up the threaded nut with the hole in between the pair of holes on the pinch weld (Figs 2A & 2B).

Vehicles with factory threaded hole in floor panel:

- a. Locate the front, center and rear mounting locations (Fig 1).
- b. Select the Passenger/Right Front Mounting Bracket (D).
- c. Attach the Bracket to the front mounting location with (1) 8mm Hex Bolt, (1) 8mm Lock Washer and (1) 8mm Flat Washer (Fig 4). DO NOT tighten hardware.

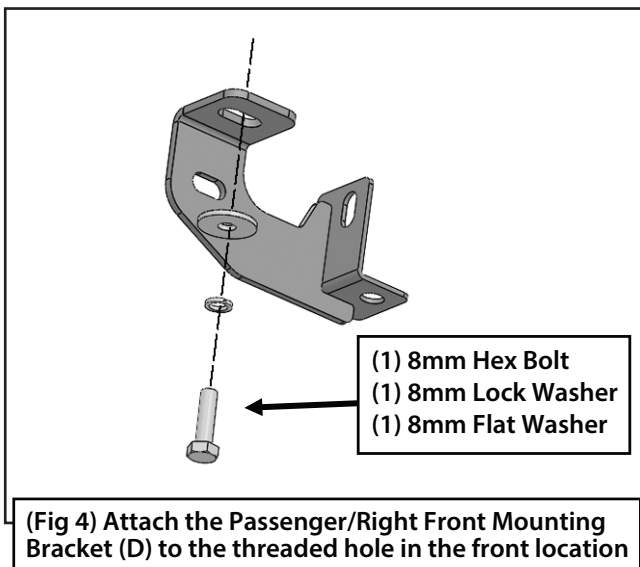
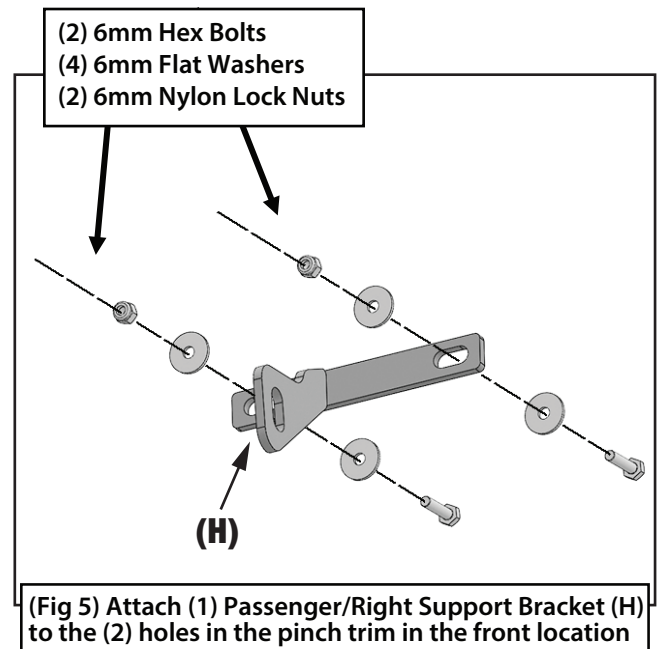
Passenger/Right Side Installation Pictured

Passenger/Right Side Installation Pictured

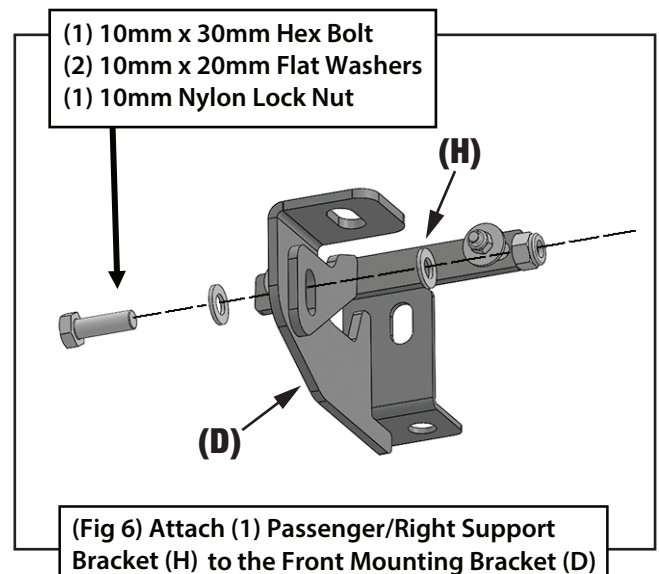
STEP 3

Select (1) Passenger/Right Support Bracket (H). Attach the Support Bracket (H) to the pinch weld with (2) 6mm Hex Bolts, (4) 6mm Flat Washers and (2) 6mm Nylon Lock Nuts (Fig 5). Attach the Support Bracket (H) to the Mounting Bracket (D) with (1) 10mm x 30mm Hex Bolt, (2) 10mm x 34mm Flat Washers and (1) 10mm Nylon Lock Nuts (Fig 6). DO NOT tighten hardware.



STEP 4

Repeat **STEPS 2 & 3** to attach the Passenger/Right Center and Rear Mounting Brackets (E and F) and Support Brackets (H) to the center and rear locations (Figs 7A, 7B & 8). **DO NOT** tighten hardware.

Passenger/Right Side Installation Pictured

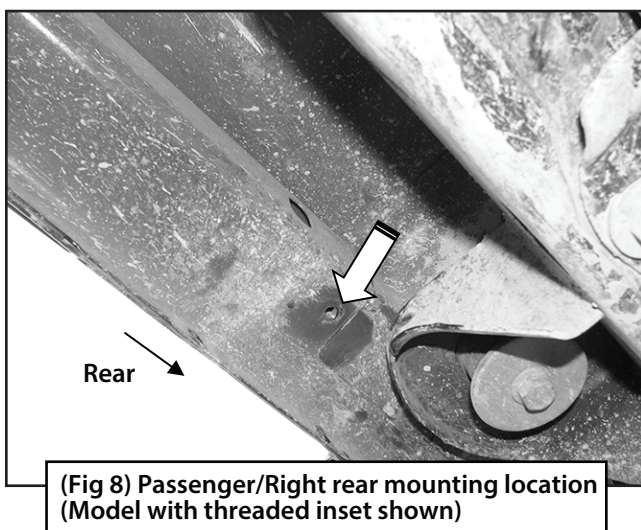
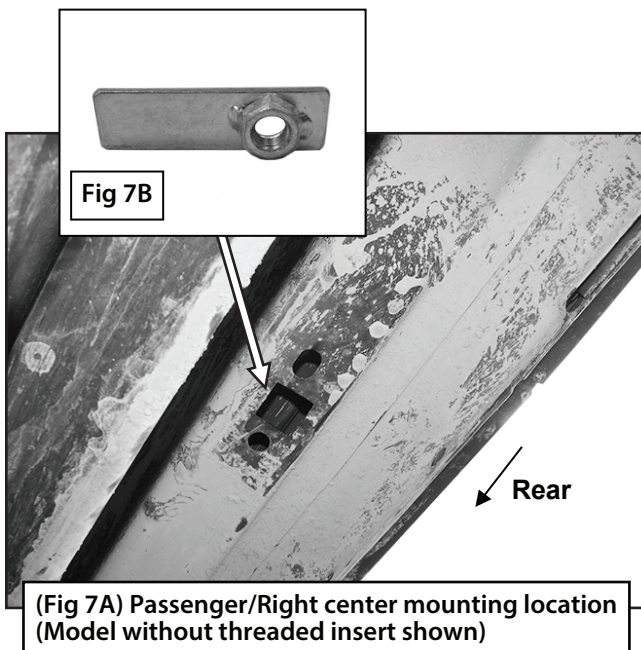

STEP 5

Select the Passenger/Right Side Sidebar. Attach the Side Sidebar to the Mounting Brackets with (6) 8mm Combo Bolts (Fig 9). **IMPORTANT:** **DO NOT** slide Side Armor on the Mounting Bracket cradles, or damage to the finish may result.

Passenger/Right Side Installation Pictured

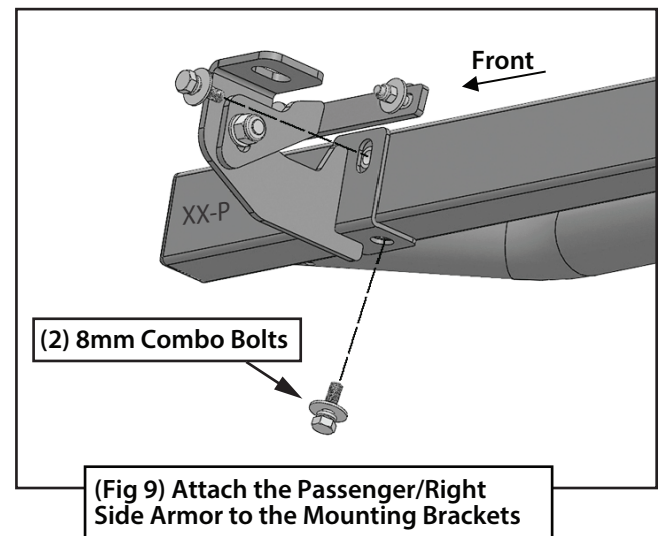

STEP 6

Level and adjust the Side Sidebar and tighten all hardware.

STEP 7

Repeat **STEPS 1-6** to attach the Driver/Left Side Sidebar.

STEP 8

Do periodic inspections to the installation to make sure that all hardware is secure and tight.